



Compliant with
New Accuracy Standards

Caged Roller LM Guide

Roller Cage Effect
Ultra-super-high
Rigidity

SRG/SRN

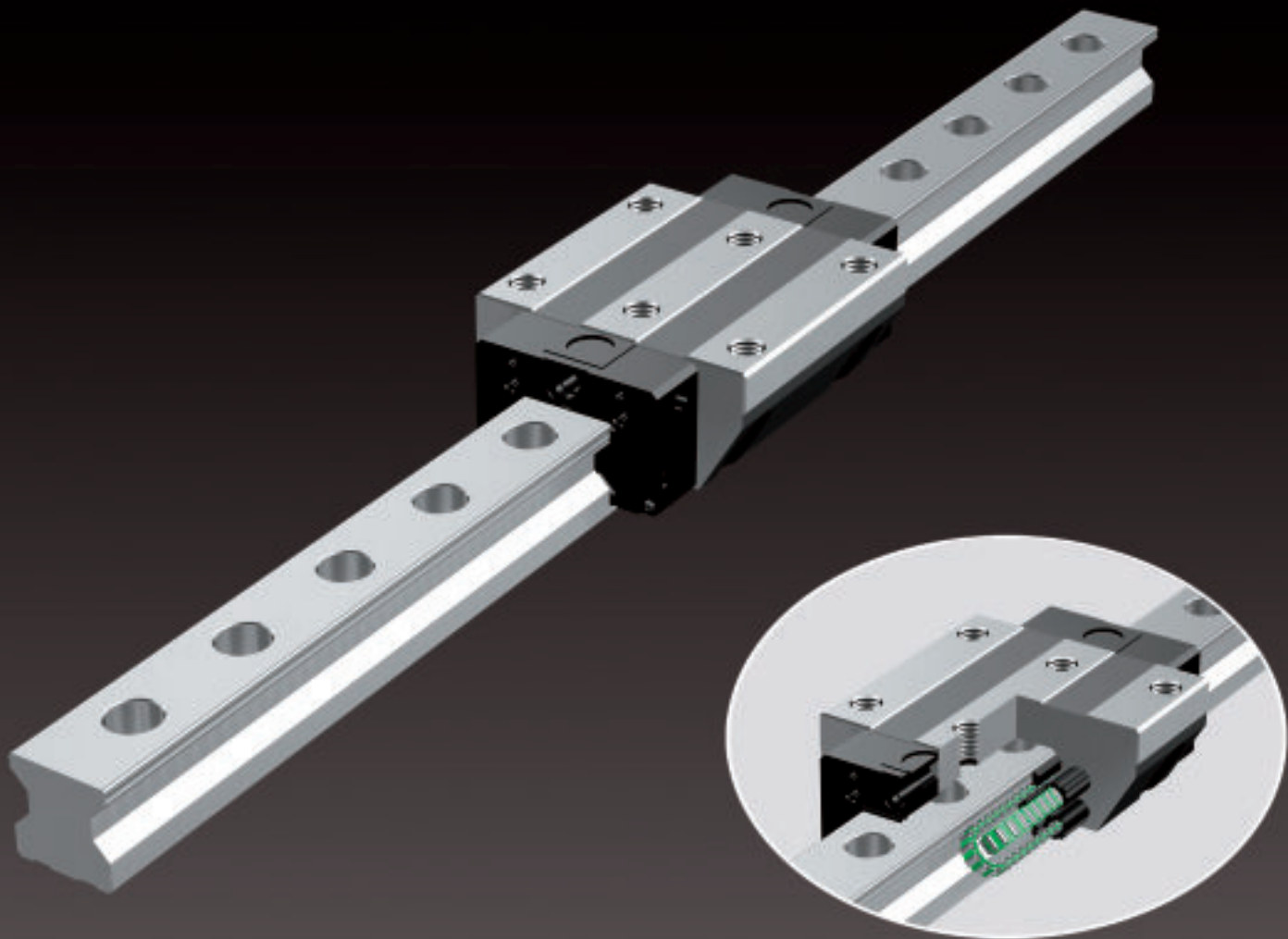

For details, visit THK at www.thk.com
*Product information is updated regularly on the THK website.

Roller Cage Effect

According to the history of rotary ball bearings, which used balls as the rolling elements, their early forms were full-ball types without ball cages.

Therefore, friction between balls caused loud noise, made high-speed rotation impossible and shortened the service life.

Twenty years later, a Caged Ball design was developed for ball bearings. The new design enabled high-speed rotation at a low noise level, and extended the service life despite a reduced number of balls used. It marked a major development of ball bearings.

Similarly, the performance of needle bearings using rollers was significantly improved by the caged roller structure, as represented in the history of bearings. The Cage Roller LM Guide has a structure that does not cause friction between rollers and allows grease to be retained in a grease pocket between adjacent rollers, thus ensuring long-term maintenance-free operation.

- Long Service Life, Long-term Maintenance-free Operation
- High-Speed Operation
- Low Noise, Acceptable Running Sound
- Smooth Motion
- Low Dust Generation

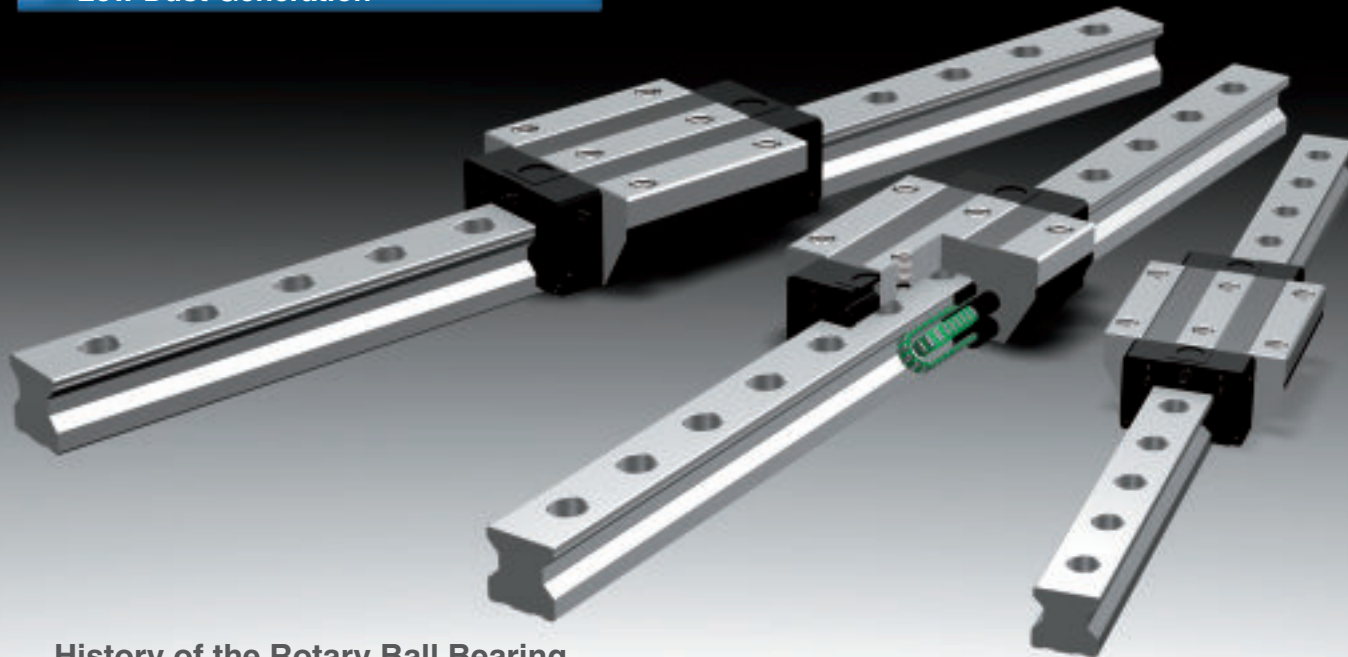

History of the Rotary Ball Bearing

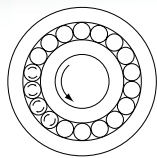

Conventional Structure

- Adjacent balls make point contact each other. As a result, unit surface pressure is high, the oil film easily breaks, and wear occurs due to friction.
- The service life becomes shorter.

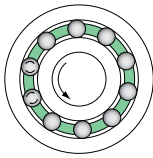

Caged Ball Structure

- The service life is prolonged due to the elimination of wear caused by friction between balls.
- The absence of friction between balls results in reduced heat generation during high-speed rotation.
- The absence of friction between balls eliminates collision noise of the balls.
- Even spacing of the balls enables them to move smoothly.
- Retention of lubricant in the ball cage ensures a long service life.

Caged Roller LM Guide

With the Caged Roller LM Guide, the use of a roller cage allows lines of evenly spaced rollers to circulate, thus to reduce fluctuations in rolling resistance and achieve smooth and stable motion. In addition, grease held in a space between the roller circulation path and the roller cage (grease pocket) is applied on the contact surface between each roller and the roller cage as the roller rotates, forming an oil film on the roller surface. This minimizes the risk of oil-film break.

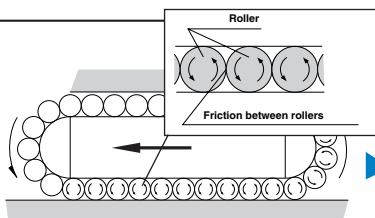

Conventional Structure

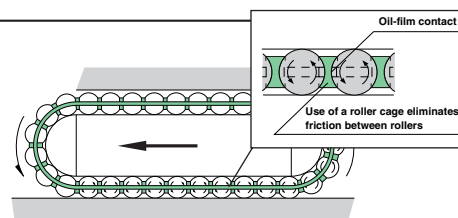

Caged Roller Structure

Ultra-super-high Rigidity Caged Roller LM Guide

SRG/SRN

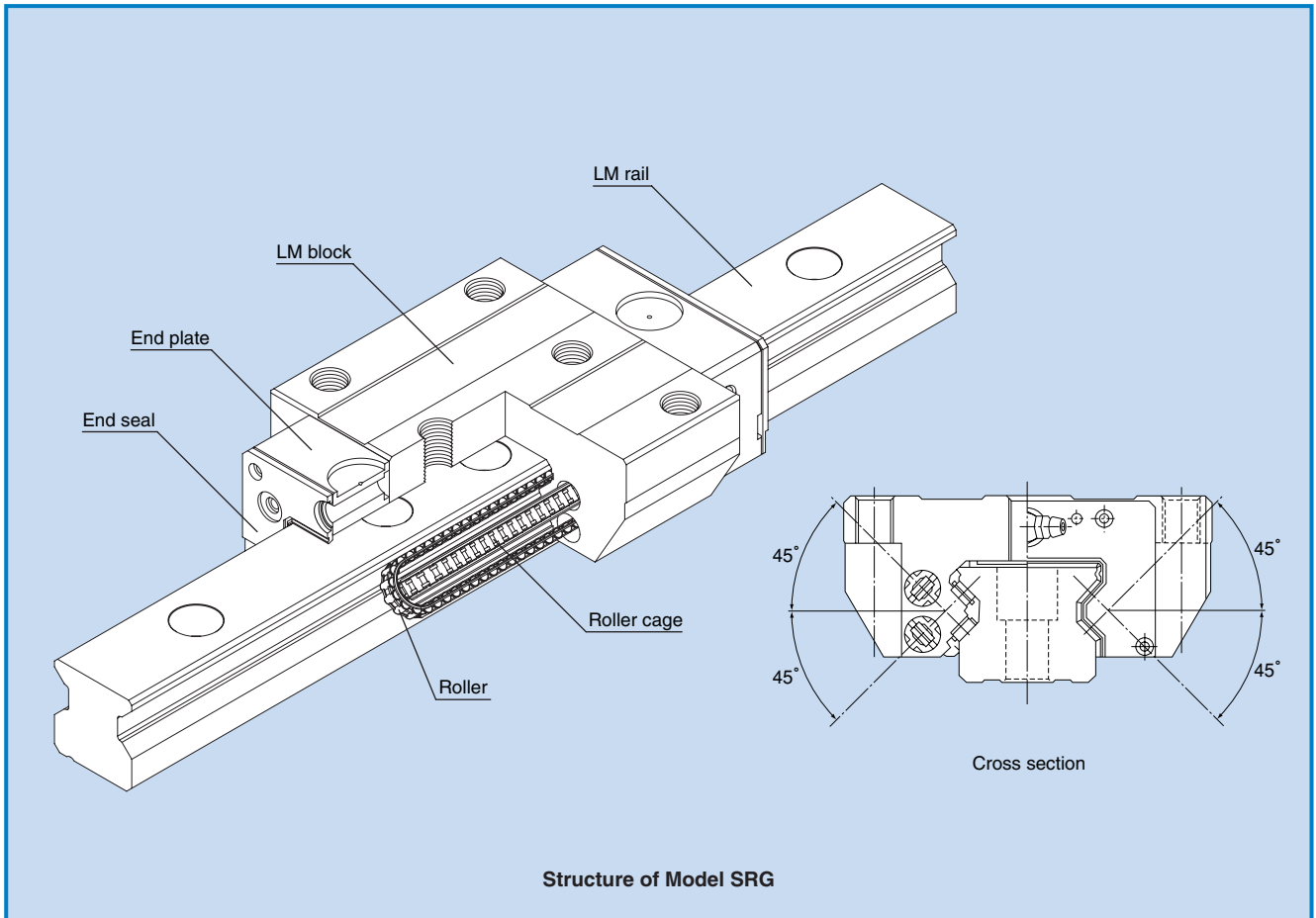

Models SRG and SRN are ultra-super-high rigidity Roller Guides that use roller cages to allow low-friction, smooth motion and achieve long-term maintenance-free operation.

● Ultra-super-high Rigidity

They achieve remarkably high rigidity by using rollers, which are less subject to deformation, for the rolling elements and having the overall roller length 1.5 times greater than the roller diameter.

● 4-way Equal Load

Each row of balls is placed at a contact angle of 45° so that the rated loads applied to the LM block are uniform in the four directions (radial, reverse radial and lateral directions), ensuring high rigidity in any direction.

● Long-term maintenance-free operation

Use of roller cages eliminates friction between rollers and increases grease retention, enabling long-term maintenance-free operation to be achieved.

● Global Standard Size

SRG and SRN are designed to have dimensions almost the same as that of the full-ball type LM Guide model HSR, which THK as a pioneer of the linear motion system has developed and is a de facto global standard model.

● High Rigidity Evaluation Data

Remarkably high rigidity is achieved by using rollers, which are less subject to deformation, for the rolling elements and having the overall roller length 1.5 times greater than the roller diameter.

[Magnitude of the preload]

SRG: radial clearance C0

Conventional type: equivalent to radial clearance C0

Radial rigidity

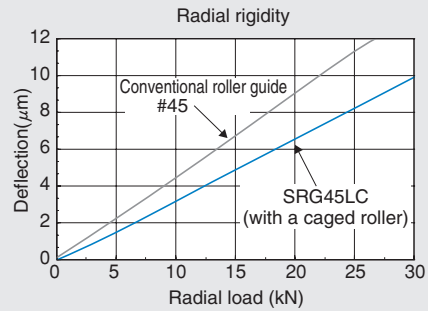
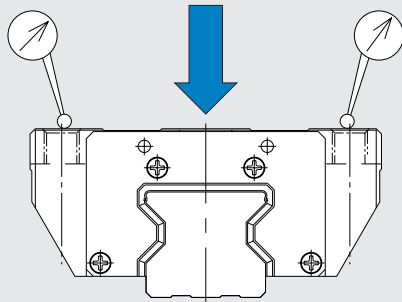

Reverse-radial rigidity

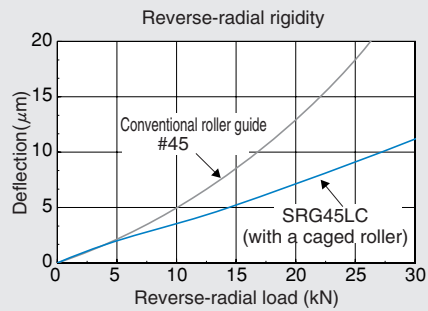
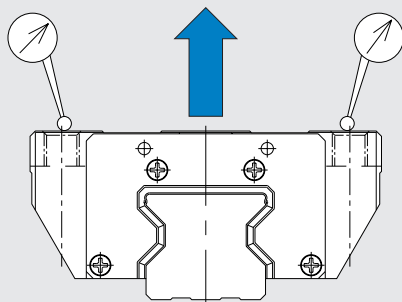

Horizontal rigidity

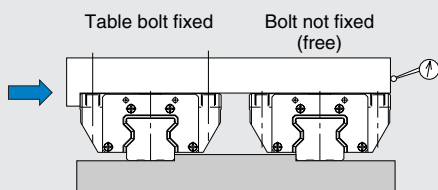

Place two rails in parallel to each other so that a moment is not applied, and measure the rigidity with one rail not fixed with bolts.

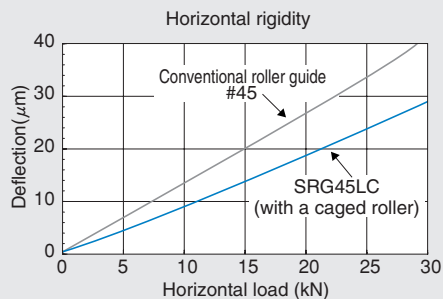

● Smoothness Evaluation Data

The roller cage allows rollers to be uniformly aligned as they circulate. As a result, fluctuation of the rolling resistance is minimized, and stable, smooth motion is achieved.

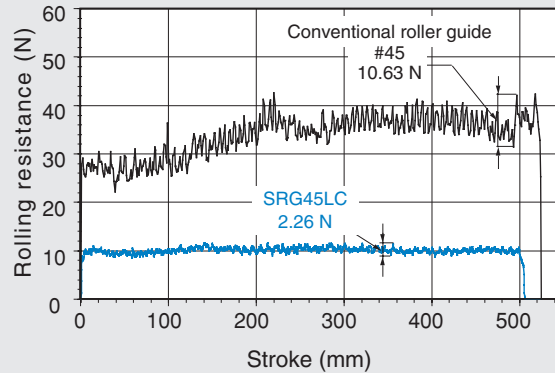

Result of Measuring Rolling Resistance Fluctuation

Conditions: Feed speed: 10 mm/s
Applied load: no load (1 block)

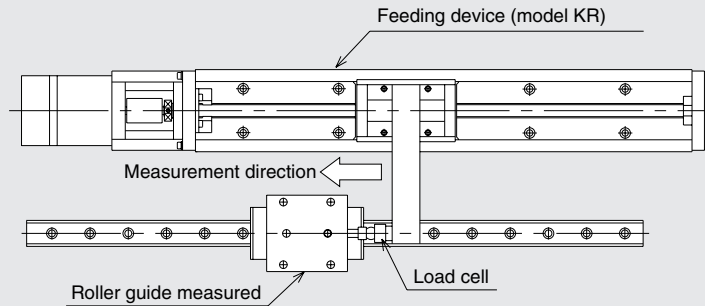

Rolling Resistance Measuring Equipment

● High durability Evaluation Data

Use of roller cages eliminates friction between rollers, reduces heat generation and increases grease retention, enabling long-term maintenance-free operation to be achieved.

Tested model: SRG45LC
Conditions: preload: clearance C0
Speed: 180 m/min
Acceleration: 1.5 G
Stroke: 2,300 mm
Lubrication: initial grease lubrication only (THK AFB-LF Grease)

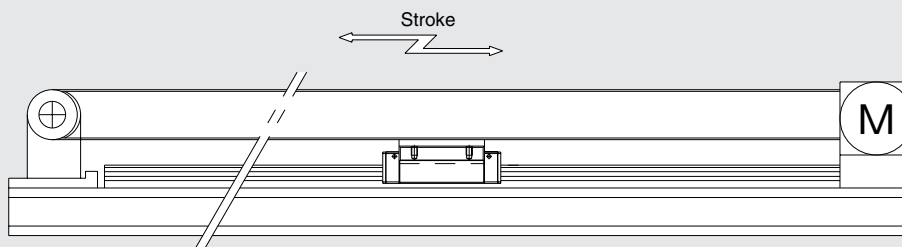

Test result: after running 15,000 km, no anomaly

Result of High Speed Durability Test

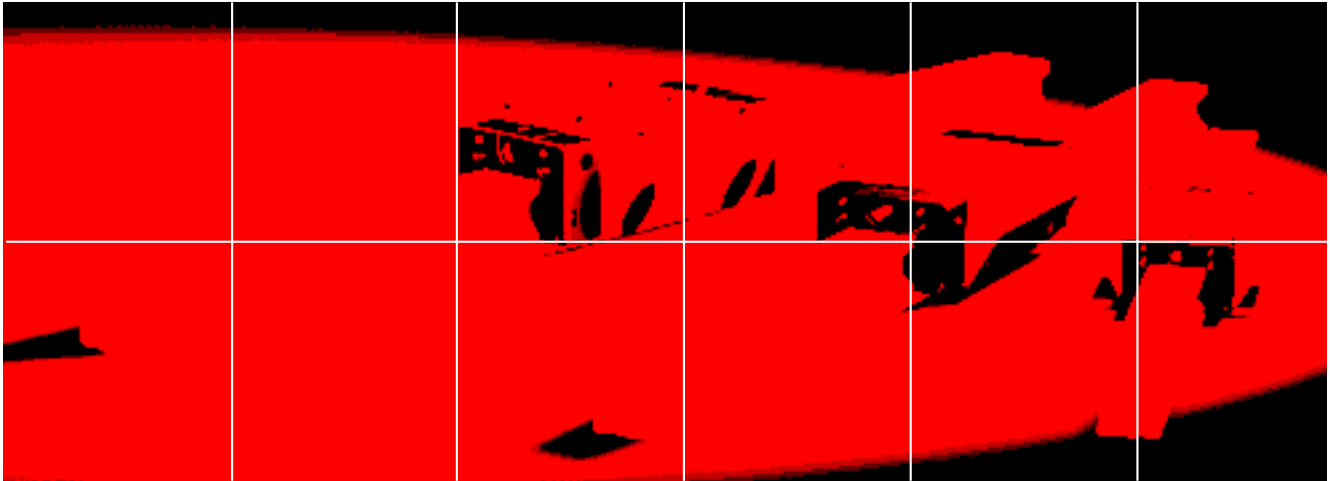

SRG/SRN Outline

Models SRG/SRN - Product Overview

Having almost the same dimensions as the de facto standard, full-ball type LM Guide model HSR, these models are superbly capable of receiving an ultra-super heavy load and optimal for machine tools.

Major applications machining center / NC lathe / grinding machine / five axis milling machine / drilling machine / NC milling machine / semiconductor manufacturing machine / molding machine

Model SRG-A

The flange of the LM block has tapped holes. Can be mounted from the top.

● SRG 15A ● SRG 20A

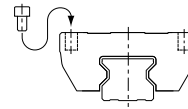
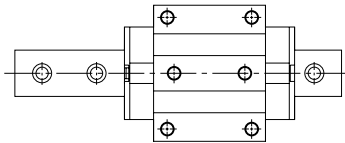

Model SRG-LA

The LM block has the same sectional shape as model SRG-A, but has a longer overall LM block length (L) and a greater rated load.

● SRG 20LA

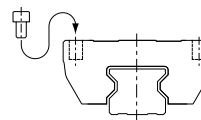
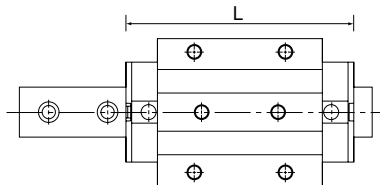

Model SRG-C

The flange of the LM block has tapped holes. Can be mounted from the top or bottom. Used in placed where the table cannot have through holes for mounting bolts.

● SRG 25C ● SRG 45C
● SRG 30C ● SRG 55C
● SRG 35C

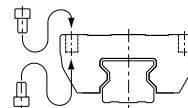
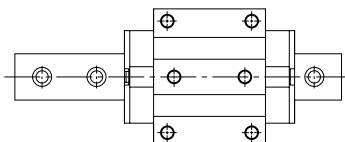

Model SRG-LC

The LM block has the same sectional shape as model SRG-C, but has a longer overall LM block length (L) and a greater rated load.

- SRG 25LC ● SRG 45LC
- SRG 30LC ● SRG 55LC
- SRG 35LC ● SRG 65LC

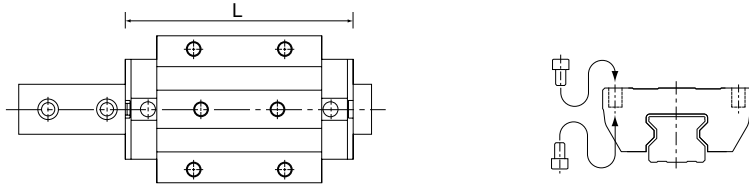

Model SRG-R

The LM block has a smaller width (W) and is equipped with tapped holes. Used in places where space for table width is limited.

- SRG 25R ● SRG 45R
- SRG 30R ● SRG 55R
- SRG 35R

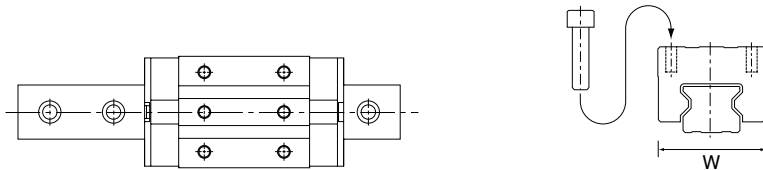

Model SRG-LR

The LM block has the same sectional shape as model SRG-R, but has a longer overall LM block length (L) and a greater rated load.

- SRG 25LR ● SRG 45LR
- SRG 30LR ● SRG 55LR
- SRG 35LR

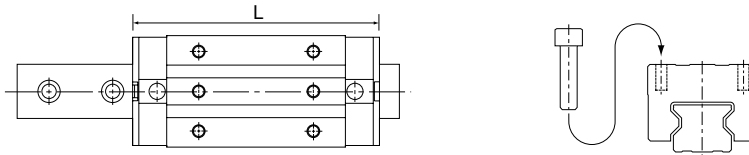

Model SRG-V

The LM block has a smaller width (W) and is equipped with tapped holes. Used in places where space for table width is limited.

- SRG 15V ● SRG 20V

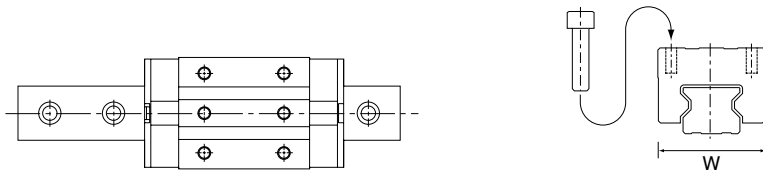

Model SRG-LV

The LM block has the same sectional shape as model SRG-V, but has a longer overall LM block length (L) and a greater rated load.

- SRG 20LV ● SRG 65LV

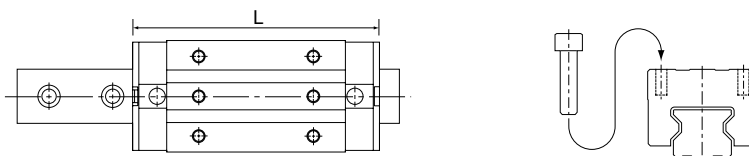

Build-to-order Models

Model SRN-C

The flange of the LM block has tapped holes. Can be mounted from the top or bottom. Used in places where the table cannot have through holes for mounting bolts.

- SRN 35C
- SRN 45C
- SRN 55C

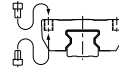
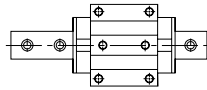

Model SRN-LC

The LM block has the same sectional shape as model SRN-C, but has a longer overall LM block length (L) and a greater rated load.

- SRN 35LC
- SRN 45LC
- SRN 55LC
- SRN 65LC

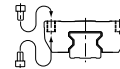
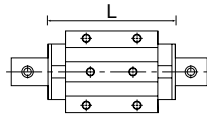

Model SRN-R

The LM block has a smaller width (W) and is equipped with tapped holes. Used in places where space for table width is limited.

- SRN 35R
- SRN 45R
- SRN 55R

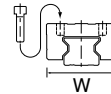
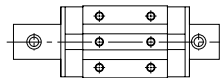

Model SRN-LR

The LM block has the same sectional shape as model SRN-R, but has a longer overall LM block length (L) and a greater rated load.

- SRN 35LR
- SRN 45LR
- SRN 55LR
- SRN 65LR

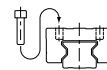
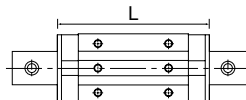

*1: Models SRG/SRN dimensional tables

Model SRG-A/LA/C/LC: starting on P. 13

Model SRG-V/LV/R/LR: starting on P. 15

Model SRN-C/LC: starting on P. 17

Model SRN-R/LR: starting on P. 17

Rated Loads in All Directions

Models SRG/SRN are capable of receiving loads in all four directions: radial, reverse-radial and lateral directions.

The basic load ratings are uniform in the four directions (radial, reverse-radial and lateral directions), and their actual values are provided in the dimensional table*1 for models SRG/SRN.

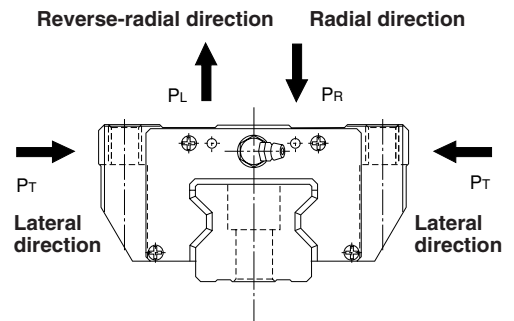

Equivalent Load

When the LM block of models SRG/SRN receives loads in all directions simultaneously, the equivalent load is obtained from the equation below.

$$P_E = P_R (P_L) + P_T$$

- P_E : Equivalent load (N)
 - Radial direction
 - Reverse-radial direction
 - Lateral direction
- P_R : Radial load (N)
- P_L : Reverse-radial load (N)
- P_T : Lateral load (N)

Service Life

The service life of an LM Guide is subject to slight variations even if multiple units of the identical model manufactured in the same process are used under the same operational conditions. Therefore, it is necessary to use the nominal life defined below as a reference value for obtaining the service life of the LM Guide.

Nominal Life

The nominal life means the total travel distance that 90% of a group of the same LM Guide model can achieve without flaking (scale-like exfoliation on the metal surface) after individually running under the same conditions.

Service Life Time

Once the nominal life (L) has been obtained, the service life time can be obtained using the equation on the right if the stroke length and the number of reciprocations are constant.

$$L = \left(\frac{f_H \cdot f_T \cdot f_C}{f_W} \cdot \frac{C}{P_C} \right)^{\frac{10}{3}} \times 100$$

- L : Nominal life (km)
- C : Basic dynamic load rating*1 (N)
- P_C : Calculated load (N)
- f_H : Hardness factor (see Fig. 1)
- f_T : Temperature factor
- f_C : Contact factor (see Table 1)
- f_W : Load factor (see Table 2)

$$L_h = \frac{L \times 10^6}{2 \times \ell_s \times n_1 \times 60}$$

- L_h : Service life time (h)
- ℓ_s : Stroke length (mm)
- n₁ : No. of reciprocations per min (min⁻¹)

*1: Basic dynamic load rating (C)

The basic dynamic load rating (C) indicates the load with constant direction and magnitude, under which the rated life (L) is L = 50 km for an LM system using balls, or L = 100 km for an LM system using rollers, when a group of identical LM system independently operating under the same conditions.

f_H : Hardness factor

To ensure the achievement of the optimum load capacity of the LM Guide, the raceway hardness must be between 58 and 64 HRC. At hardness below this range, the basic dynamic and static load ratings decrease. Therefore, the rating values must be multiplied by the respective hardness factors (f_H). Since the LM Guide has sufficient hardness, the f_H value for the LM Guide is normally 1.0.

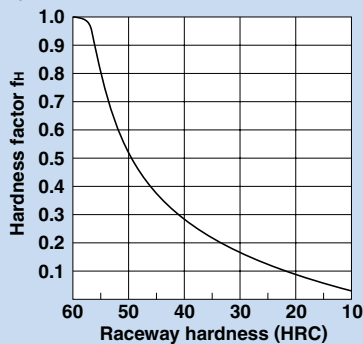

Fig. 1

f_C : Contact factor

When multiple LM blocks are used in close contact with each other, it is difficult to achieve uniform load distribution due to moment loads and mounting-surface accuracy. When using multiple blocks in close contact with each other, multiply the basic load rating (C or C₀) by the corresponding contact factor indicated in Table 1.

Note: When uneven load distribution is expected in a large machine, consider using a contact factor from Table 1.

Table 1 Contact Factor (f_C)

Number of blocks used in close contact	Contact factor f _C
2	0.81
3	0.72
4	0.66
5	0.61
6 or greater	0.6
Normal use	1

f_T : Temperature factor

Since the service temperature of a Caged Roller LM Guide is normally 80°C or below, the temperature factor f_T is 1.0.

f_W : Load factor

In general, reciprocating machines tend to produce vibrations or impact during operation. Additionally, it is especially difficult to accurately determine all vibrations generated during high-speed operation and impacts produced each time the machine starts and stops. Therefore, where the effects of speed and vibration are estimated to be significant, divide the basic dynamic load rating (C) by a load factor selected from Table 2, which contains empirically obtained data.

Table 2 Load Factor (f_W)

Vibration/impact	Speed (V)	f _W
Faint	Very slow V ≤ 0.25m/s	1 to 1.2
Weak	Slow 0.25 < V ≤ 1m/s	1.2 to 1.5
Medium	Medium 1 < V ≤ 2m/s	1.5 to 2
Strong	Fast V > 2m/s	2 to 3.5

***1: Preload**

Preload is an internal load applied to the rolling elements (roller) in advance in order to increase the rigidity of the LM block. The clearances of all SRG/SRN models are adjusted to specified values before shipment, and therefore it is unnecessary to adjust their preloads.

Radial Clearance Standard

Since the radial clearance of an LM Guide greatly affects the running accuracy, load carrying capacity and rigidity of the LM Guide, it is important to select an appropriate clearance according to the application.

In general, selecting a negative clearance (i.e., a preload*1 is applied) while taking into account possible vibrations and impact generated from reciprocating motion favorably affects the service life and the accuracy.

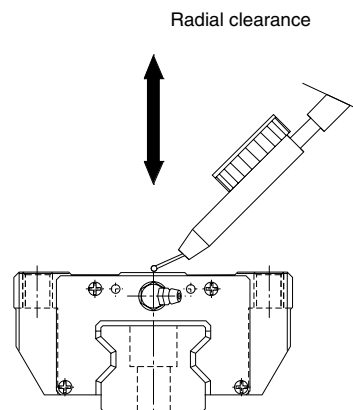

Radial clearance of models SRG/SRN

Unit: μm

Model No.	Indication symbol	Normal	Light preload	Medium preload
	No symbol		C1	C0
15		- 0.5 to 0	- 1 to - 0.5	- 2 to - 1
20		- 0.8 to 0	- 2 to - 0.8	- 3 to - 2
25		- 2 to - 1	- 3 to - 2	- 4 to - 3
30		- 2 to - 1	- 3 to - 2	- 4 to - 3
35		- 2 to - 1	- 3 to - 2	- 5 to - 3
45		- 2 to - 1	- 3 to - 2	- 5 to - 3
55		- 2 to - 1	- 4 to - 2	- 6 to - 4
65		- 3 to - 1	- 5 to - 3	- 8 to - 5

Accuracy Standard

Accuracies of models SRG/SRN are specified in terms of running parallelism^{*2}, dimensional tolerance for height and width, and height and width difference between a pair^{*3,4} when 2 or more LM blocks are used on one rail or when 2 or more rails are mounted on the same plane.

Accuracies of models SRG/SRN are categorized into Precision grade (P), Super precision grade (SP) and Ultra precision grade (UP) as indicated in the table below.

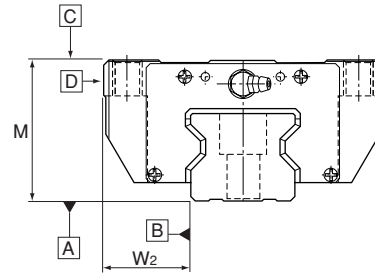

*2: Running parallelism

It refers to a parallelism error between the LM block and the LM rail datum plane when the LM block travels the whole length of the LM rail, which is secured on the reference datum plane using bolts.

*3: Difference in height M

It indicates a difference between the minimum and maximum values in height (M) of each of the LM blocks used on the same plane in combination.

*4: Difference in width W₂

It indicates a difference between the minimum and maximum values in width (W₂) between each of the LM blocks, mounted on one LM rail in combination, and the LM rail.

Unit: mm

Model No.	Accuracy standard	Precision grade	Super precision grade	Ultra precision grade
	Item	P	SP	UP
15	Dimensional tolerance for height M	0	0	0
	Difference in height M	0.006	0.004	0.003
	Dimensional tolerance for width W ₂	0	0	0
	Difference in width W ₂	0.006	0.004	0.003
20	Running parallelism of surface C against surface A	as shown in the table below		
	Running parallelism of surface D against surface B	as shown in the table below		
25	Dimensional tolerance for height M	0	0	0
	Difference in height M	0.007	0.005	0.003
	Dimensional tolerance for width W ₂	0	0	0
	Difference in width W ₂	0.007	0.005	0.003
30	Running parallelism of surface C against surface A	as shown in the table below		
	Running parallelism of surface D against surface B	as shown in the table below		
35	Dimensional tolerance for height M	0	0	0
	Difference in height M	0.007	0.005	0.003
	Dimensional tolerance for width W ₂	0	0	0
	Difference in width W ₂	0.007	0.005	0.003
45	Running parallelism of surface C against surface A	as shown in the table below		
	Running parallelism of surface D against surface B	as shown in the table below		
55	Dimensional tolerance for height M	0	0	0
	Difference in height M	0.007	0.005	0.003
	Dimensional tolerance for width W ₂	0	0	0
	Difference in width W ₂	0.007	0.005	0.003
65	Running parallelism of surface C against surface A	as shown in the table below		
	Running parallelism of surface D against surface B	as shown in the table below		

LM Rail Length and Running Parallelism for Models SRG/SRN

Unit: μm

LM rail length (mm)		Running Parallelism Values		
Above	Or less	Precision grade	Super precision grade	Ultra precision grade
		P	SP	UP
—	50	2	1.5	1
50	80	2	1.5	1
80	125	2	1.5	1
125	200	2	1.5	1
200	250	2.5	1.5	1
250	315	3	1.5	1
315	400	3.5	2	1.5
400	500	4.5	2.5	1.5
500	630	5	3	2
630	800	6	3.5	2
800	1000	6.5	4	2.5
1000	1250	7.5	4.5	3
1250	1600	8	5	4
1600	2000	8.5	5.5	4.5
2000	2500	9.5	6	5
2500	3090	11	6.5	5.5

Shoulder Height of the Mounting Base and the Corner Radius

Normally, the mounting base for the LM rail and the LM block has a datum plane on the side face of the shoulder of the base in order to allow easy installation and highly accurate positioning.

The corner of the mounting shoulder must be machined to have a recess, or machined to be smaller than the corner radius, to prevent interference with the chamfer of the LM rail or the LM block.

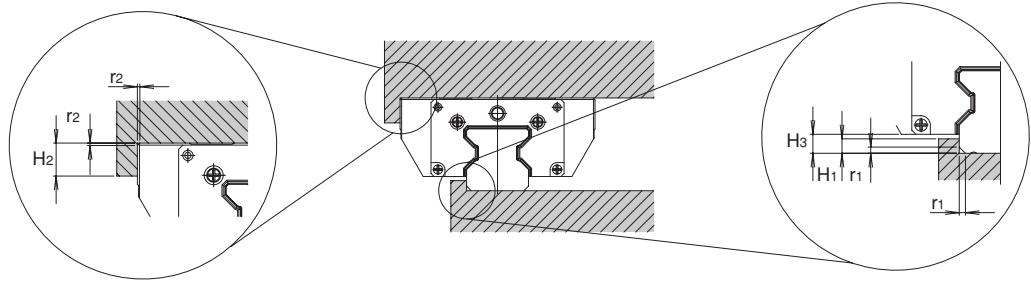

■ Model SRG

Unit: mm

Model No.	Corner radius for the LM rail r_1 (max)	Corner radius for the LM block r_2 (max)	Shoulder height for the LM rail H_1	Shoulder height for the LM block H_2	H_3
15	0.5	0.5	2.5	4	4
20	0.5	0.5	3.5	5	4.6
25	1	1	4	5	4.5
30	1	1	4.5	5	5
35	1	1	5	6	6
45	1.5	1.5	6	8	8
55	1.5	1.5	8	10	10
65	1.5	2	9	10	11.5

■ Model SRN

Unit: mm

Model No.	Corner radius for the LM rail r_1 (max)	Corner radius for the LM block r_2 (max)	Shoulder height for the LM rail H_1	Shoulder height for the LM block H_2	H_3
35	1	1	5	6	6
45	1.5	1.5	6	8	7
55	1.5	1.5	8	10	10
65	1.5	2	8	10	10

Error Allowance on the Mounting Surface

With Caged Roller LM Guide models SRG/SRN, the rollers serving as the rolling elements ensure high rigidity and the roller retainer prevents rollers from skewing. However, the mounting surface needs to be machined with high precision. A large accuracy error of the mounting surface affects the rolling resistance and the service life. The following shows the maximum error allowance (limit value) of the mounting surface according to the radial clearance.

Error Allowance in Parallelism (P) between Two Rails

Unit: mm

Radial clearance	Normal	C1	C0
Model No.			
SRG 15	0.005	0.003	0.003
SRG 20	0.008	0.006	0.004
SRG 25	0.009	0.007	0.005
SRG 30	0.011	0.008	0.006
SRG/SRN 35	0.014	0.010	0.007
SRG/SRN 45	0.017	0.013	0.009
SRG/SRN 55	0.021	0.014	0.011
SRG/SRN 65	0.027	0.018	0.014

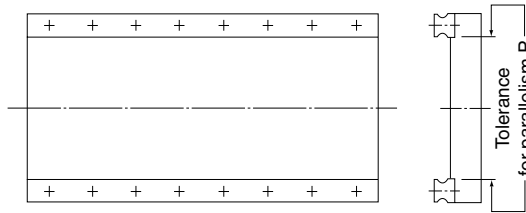

Error Allowance in Vertical Level (X) between Two Rails

Unit: mm

Radial clearance	Normal	C1	C0
Error allowance on the mounting surface (X)	0.00030a	0.00021a	0.00011a

$X = X_1 + X_2$: X_1 : Level difference on the rail mounting surface
 X_2 : Level difference on the block mounting surface

Example of calculation
 When the rail span: $a = 500$ mm
 Error allowance on the mounting surface:
 $X = 0.0003 \times 500$
 $= 0.15$

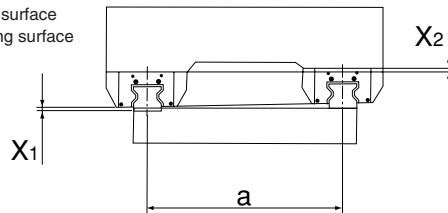

Error Allowance in Level (Y) in the Axial Direction

Unit: mm

Permissible error on the mounting surface	0.000036b
---	-----------

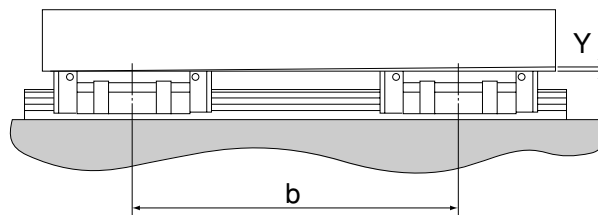

Models SRG-A/SRG-LA SRG-C/SRG-LC

Dimensional Table for Models SRG-A/SRG-LA and Models SRG-C/SRG-LC

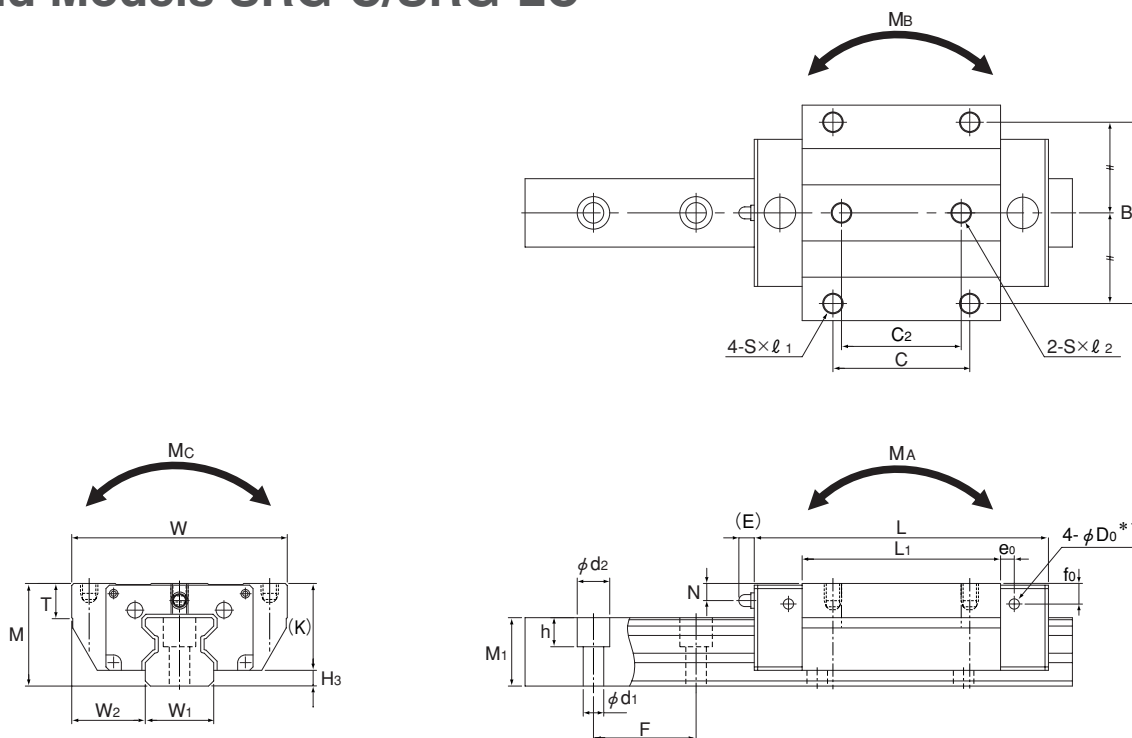

Models SRG15 and 20A/LA

Model No.	Outer dimensions			LM block dimensions																			Grease nipple	H_3
	Height	Width	Length	B	C	C_2	S	H	l_1	l_2	L_1	T	T_1	K	N	E	e_0	f_0	D_0					
	M	W	L																					
SRG 15A	24	47	69.2	38	30	26	M 5	—	8	7.5	45	7	—	20	4	4.5	4	6	2.9	PB107	4			
SRG 20A SRG 20LA	30	63	86.2 106.2	53	40	35	M 6	—	10	9	58 78	10	—	25.4	5	4.5	4	6	2.9	PB107	4.6			
SRG 25C SRG 25LC	36	70	95.5 115.1	57	45	40	M 8	6.8	—	—	65.5 85.1	9.5	10	31.5	5.5	12	6	6.4	5.2	B-M6F	4.5			
SRG 30C SRG 30LC	42	90	111 135	72	52	44	M10	8.5	—	—	75 99	12	14	37	6.5	12	6	6.2	5.2	B-M6F	5			
SRG 35C SRG 35LC	48	100	125 155	82	62	52	M10	8.5	—	—	82.2 112.2	11.5	10	42	6.5	12	6	6	5.2	B-M6F	6			
SRG 45C SRG 45LC	60	120	155 190	100	80	60	M12	10.5	—	—	107 142	14.5	15	52	10	16	7	7	5.2	B-PT1/8	8			
SRG 55C SRG 55LC	70	140	185 235	116	95	70	M14	12.5	—	—	129.2 179.2	17.5	18	60	12	16	9	8.5	5.2	B-PT1/8	10			
SRG 65LC	90	170	303	142	110	82	M16	14.5	—	—	229.8	19.5	20	78.5	17	16	9	13.5	5.2	B-PT1/8	11.5			

■ Example of model number coding

SRG45 LC 2 QZ KKHH C0 +1200L P T - II

1 2 3 4 5 6 7 8 9 10

1 Model number 2 Type of LM block 3 No. of LM blocks used on the same rail 4 With QZ Lubricator attached 5 Symbol for contamination protection accessory (see page 22) 6 Radial clearance symbol (see page 9) 7 LM rail length (in mm) 8 Accuracy symbol (page 10) 9 Symbol for joint LM rail 10 No. of LM rails used on the same plane

Note This model number indicates that a single-rail unit constitutes one set (i.e., required number of sets when 2 rails are used in parallel is 2 at a minimum). Those models attached with QZ Lubricator cannot have a grease nipple.

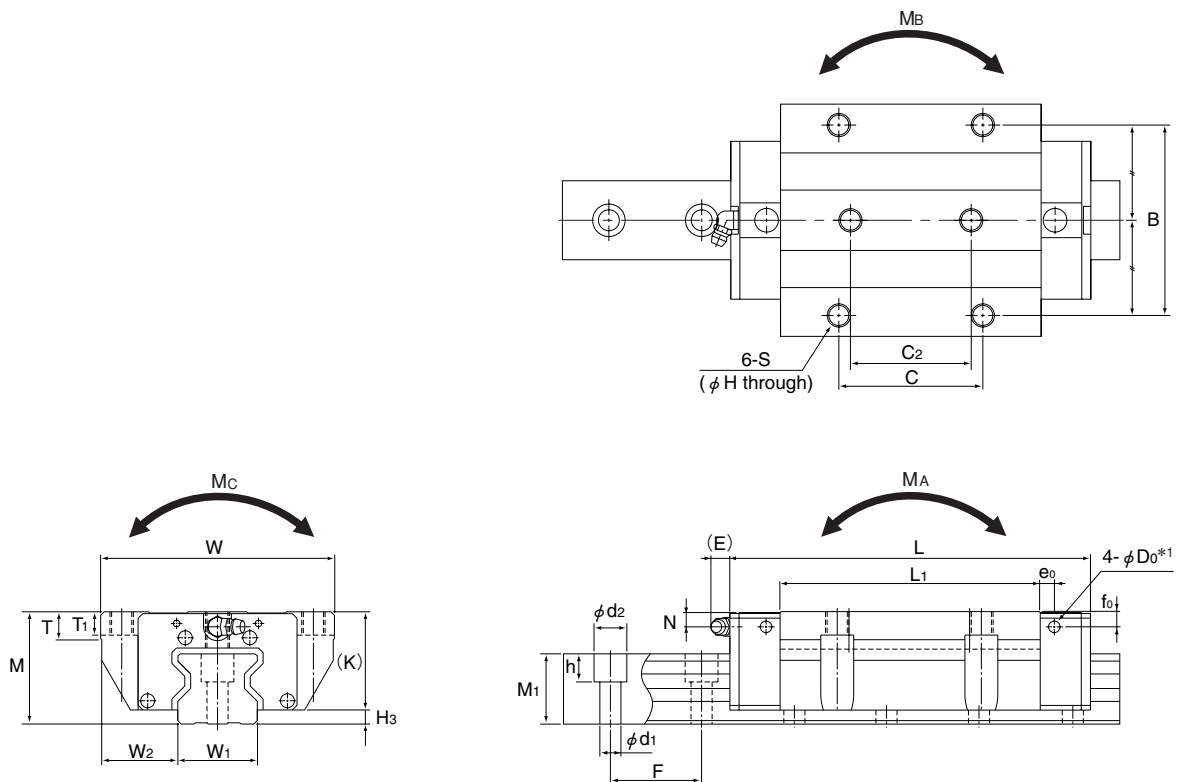

Models SRG25 to 65C/LC

Unit: mm

	LM rail dimensions					Basic load rating		Permissible static moment kN-m*3					Mass		
	Width W ₁ 0 -0.05	W ₂	Height M ₁	Pitch F	d ₁ ×d ₂ ×h	Length Max*2	C [kN]	C ₀ [kN]	M _A		M _B		M _C	LM block [kg]	LM rail [kg/m]
									1 block	Double blocks	1 block	Double blocks	1 block		
	15	16	15.5	30	4.5×7.5×5.3	2500	11.3	25.8	0.21	1.24	0.21	1.24	0.24	0.20	1.58
	20	21.5	20	30	6×9.5×8.5	3000	21 26.7	46.9 63.8	0.48 0.88	2.74 4.49	0.48 0.88	2.74 4.49	0.58 0.79	0.42 0.57	2.58
	23	23.5	23	30	7×11×9	3000	27.9 34.2	57.5 75	0.641 1.07	3.7 5.74	0.641 1.07	3.7 5.74	0.795 1.03	0.7 0.9	3.6
	28	31	26	40	9×14×12	3000	39.3 48.3	82.5 108	1.02 1.76	6.21 9.73	1.02 1.76	6.21 9.73	1.47 1.92	1.2 1.6	4.4
	34	33	30	40	9×14×12	3000	59.1 76	119 165	1.66 3.13	10.1 17	1.66 3.13	10.1 17	2.39 3.31	1.9 2.4	6.9
	45	37.5	37	52.5	14×20×17	3090	91.9 115	192 256	3.49 6.13	20 32.2	3.49 6.13	20 32.2	4.98 6.64	3.7 4.5	11.6
	53	43.5	43	60	16×23×20	3060	131 167	266 366	5.82 10.8	33 57	5.82 10.8	33 57	8.19 11.2	5.9 7.8	15.8
	63	53.5	54	75	18×26×22	3000	278	599	22.7	120	22.7	120	22.1	16.4	23.7

Note *1 Pilot holes for side nipples are not drilled through in order to prevent foreign material from entering the product. THK will mount grease nipples per your request. Therefore, do not use the side nipple pilot holes for purposes other than mounting a grease nipple.

*2 The maximum length under "Length" indicates the standard maximum length of an LM rail.

*3 Permissible static moment: 1 block: permissible static moment value with 1 LM block
Double blocks: permissible static moment value with 2 blocks closely contacting with each other

Models SRG-V/SRG-LV SRG-R/SRG-LR

Dimensional Table for Models SRG-V/SRG-LV and Models SRG-R/SRG-LR

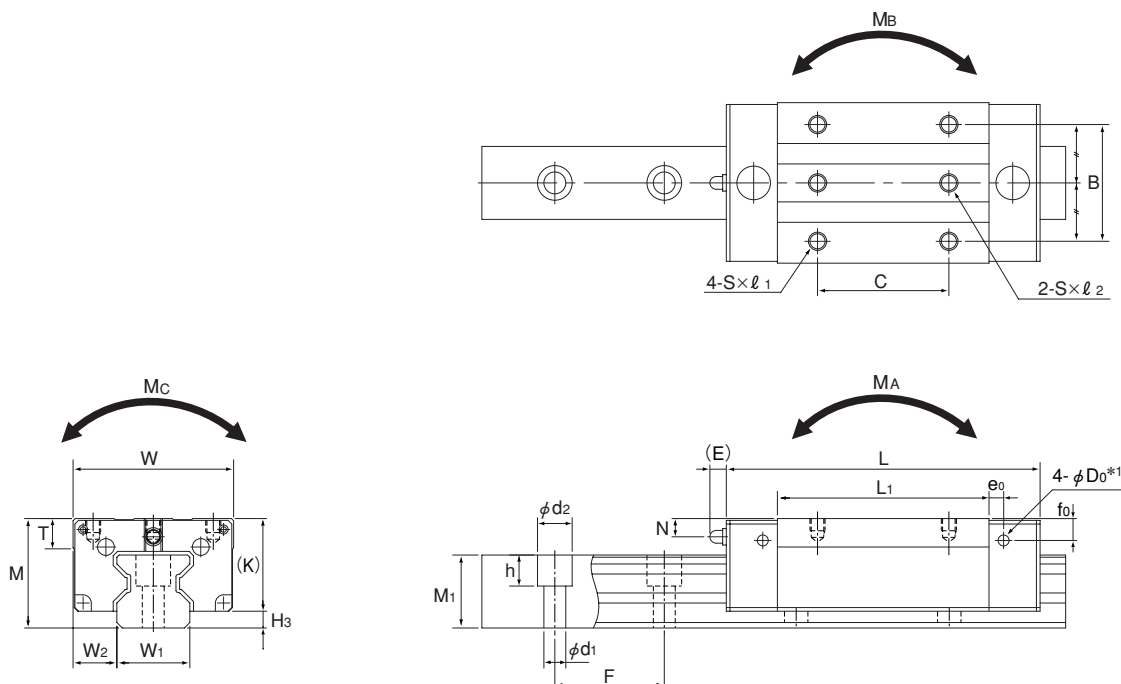

Models SRG15 and 20V/LV

Model No.	Outer dimensions			LM block dimensions																Grease nipple	H ₃
	Height M	Width W	Length L	B	C	S	l	l ₁	l ₂	L ₁	T	K	N	E	e ₀	f ₀	D ₀				
SRG 15V	24	34	69.2	26	26	M 4	—	5	7.5	45	6	20	4	4.5	4	6	2.9	PB107	4		
SRG 20V SRG 20LV	30	44	86.2 106.2	32	36 50	M 5	—	7	9	58 78	8	25.4	5	4.5	4	6	2.9	PB107	4.6		
SRG 25R SRG 25LR	40	48	95.5 115.1	35	35 50	M 6	9	—	—	65.5 85.1	9.5	35.5	9.5	12	6	10.4	5.2	B-M6F	4.5		
SRG 30R SRG 30LR	45	60	111 135	40	40 60	M 8	10	—	—	75 99	12	40	9.5	12	6	9.2	5.2	B-M6F	5		
SRG 35R SRG 35LR	55	70	125 155	50	50 72	M 8	12	—	—	82.2 112.2	18.5	49	13.5	12	6	13	5.2	B-M6F	6		
SRG 45R SRG 45LR	70	86	155 190	60	60 80	M10	20	—	—	107 142	24.5	62	20	16	7	17	5.2	B-PT1/8	8		
SRG 55R SRG 55LR	80	100	185 235	75	75 95	M12	18	—	—	129.2 179.2	27.5	70	22	16	9	18.5	5.2	B-PT1/8	10		
SRG 65LV	90	126	303	76	120	M16	20	—	—	229.8	19.5	78.5	17	16	9	13.5	5.2	B-PT1/8	11.5		

Example of model number coding

SRG45 LR 2 QZ KKHH C0 +1200L P T - II

1 2 3 4 5 6 7 8 9 10

1 Model number 2 Type of LM block 3 No. of LM blocks used on the same rail 4 With QZ Lubricator attached 5 Symbol for contamination protection accessory (see page 22) 6 Radial clearance symbol (see page 9) 7 LM rail length (in mm) 8 Accuracy symbol (page 10) 9 Symbol for joint LM rail 10 No. of LM rails used on the same plane

Note This model number indicates that a single-rail unit constitutes one set (i.e., required number of sets when 2 rails are used in parallel is 2 at a minimum). Those models attached with QZ Lubricator cannot have a grease nipple.

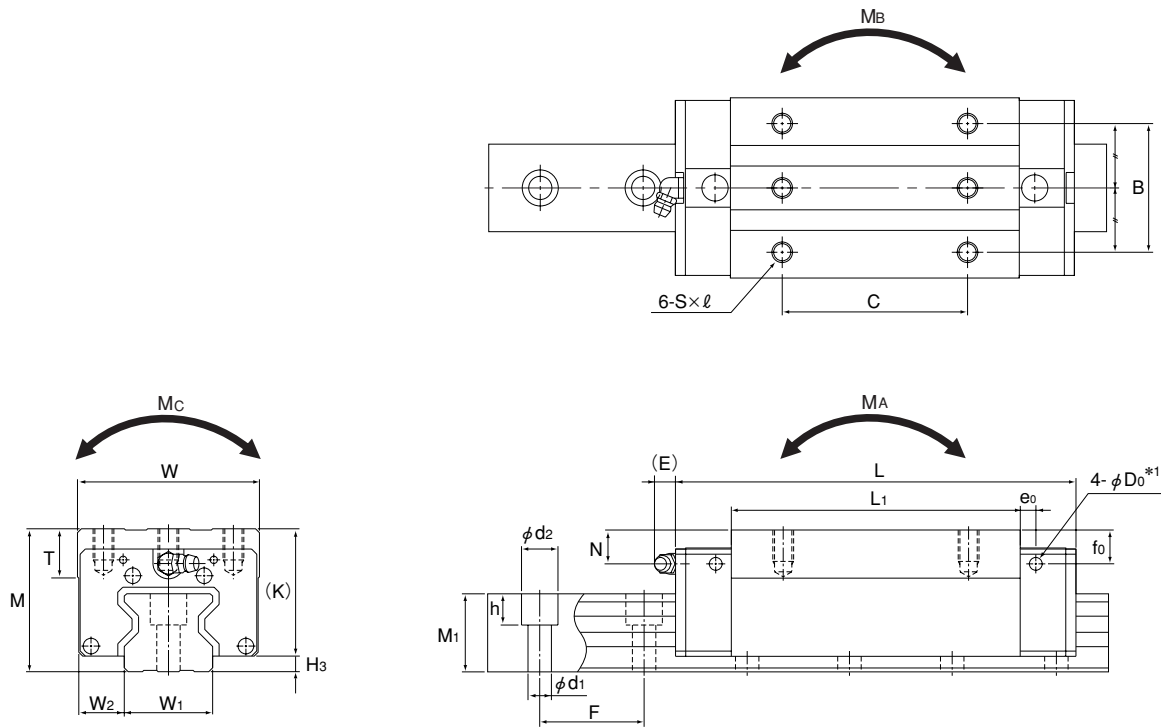

Models SRG25 to 65R/LR/LV

Unit: mm

	LM rail dimensions						Basic load rating		Permissible static moment kN-m*3					Mass	
	Width W ₁ 0 -0.05	W ₂	Height M ₁	Pitch F	d ₁ ×d ₂ ×h	Length Max*2	C [kN]	C ₀ [kN]	M _A		M _B		M _C	LM block [kg]	LM rail [kg/m]
									1 block	Double blocks	1 block	Double blocks			
15	9.5	15.5	30	4.5×7.5×5.3	2500	11.3	25.8	0.21	1.24	0.21	1.24	0.24	0.15	1.58	
20	12	20	30	6×9.5×8.5	3000	21	46.9	0.48	2.74	0.48	2.74	0.58	0.28	2.58	
						26.7	63.8	0.88	4.49	0.88	4.49	0.79	0.38		
23	12.5	23	30	7×11×9	3000	27.9	57.5	0.641	3.7	0.641	3.7	0.795	0.6	3.6	
						34.2	75	1.07	5.74	1.07	5.74	1.03	0.8		
28	16	26	40	9×14×12	3000	39.3	82.5	1.02	6.21	1.02	6.21	1.47	0.9	4.4	
						48.3	108	1.76	9.73	1.76	9.73	1.92	1.2		
34	18	30	40	9×14×12	3000	59.1	119	1.66	10.1	1.66	10.1	2.39	1.6	6.9	
						76	165	3.13	17	3.13	17	3.31	2.1		
45	20.5	37	52.5	14×20×17	3090	91.9	192	3.49	20	3.49	20	4.98	3.2	11.6	
						115	256	6.13	32.2	6.13	32.2	6.64	4.1		
53	23.5	43	60	16×23×20	3060	131	266	5.82	33	5.82	33	8.19	5	15.8	
						167	366	10.8	57	10.8	57	11.2	6.9		
63	31.5	54	75	18×26×22	3000	278	599	22.7	120	22.7	120	22.1	12.1	23.7	

Note

*1 Pilot holes for side nipples are not drilled through in order to prevent foreign material from entering the product. THK will mount grease nipples per your request. Therefore, do not use the side nipple pilot holes for purposes other than mounting a grease nipple.

*2 The maximum length under "Length" indicates the standard maximum length of an LM rail.

*3 Permissible static moment: 1 block: permissible static moment value with 1 LM block

Double blocks: permissible static moment value with 2 blocks closely contacting with each other

Models SRN-C/SRN-LC SRN-R/SRN-LR

Dimensional Table for Models SRN-C/SRN-LC and Models SRN-R/SRN-LR Build-to-order Models

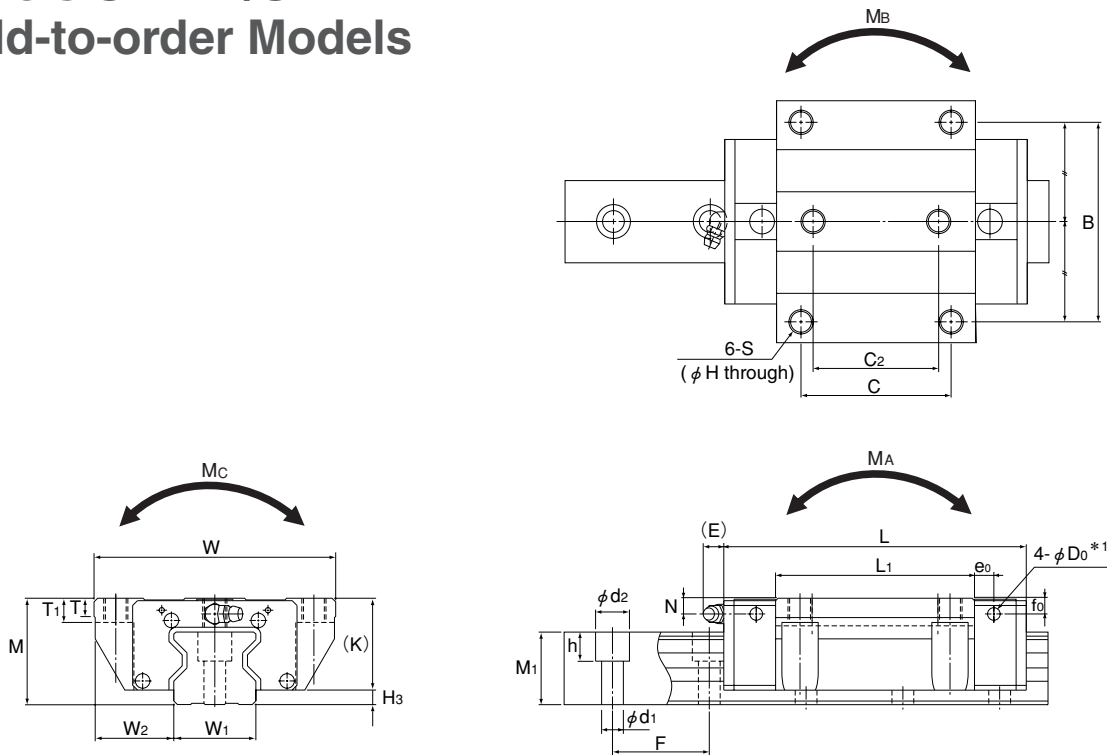

Models C/LC

Model No.	Outer dimensions			LM block dimensions																Grease nipple	H ₃
	Height M	Width W	Length L	B	C	C ₂	S	ℓ	H	L ₁	T	T ₁	K	N	E	e ₀	f ₀	D ₀			
SRN 35C SRN 35LC	44	100	125 155	82	62	52	M10	—	8.5	82.2 112.2	7.5	10	38	6.5	12	8	6.5	5.2	B-M6F	6	
SRN 35R SRN 35LR	44	70	125 155	50	50 72	—	M 8	9	—	82.2 112.2	7.5	—	38	6.5	12	8	6.5	5.2	B-M6F	6	
SRN 45C SRN 45LC	52	120	155 190	100	80	60	M12	—	10.5	107 142	7.5	15	45	7	12	8.5	7	5.2	B-M6F	7	
SRN 45R SRN 45LR	52	86	155 190	60	60 80	—	M10	11	—	107 142	7.5	—	45	7	12	8.5	7	5.2	B-M6F	7	
SRN 55C SRN 55LC	63	140	185 235	116	95	70	M14	—	12.5	129 179.2	10.5	18	53	8	16	10	8	5.2	PT1/8	10	
SRN 55R SRN 55LR	63	100	185 235	75	75 95	—	M12	13	—	129 179.2	10.5	—	53	8	16	10	8	5.2	PT1/8	10	
SRN 65LC	75	170	303	142	110	82	M16	—	14.5	229.8	19.5	20	65	14	16	9	11	5.2	PT1/8	11.5	
SRN 65LR	75	126	303	76	120	—	M16	16	—	229.8	19.5	—	65	14	16	9	11	5.2	PT1/8	11.5	

Example of model number coding

SRN45 C 2 KK C0 +1160L P T - II

1 2 3 4 5 6 7 8 9

1 Model number 2 Type of LM block 3 No. of LM blocks used on the same rail 4 Symbol for contamination protection accessory (see page 22) 5 Radial clearance symbol (see page 9) 6 LM rail length (in mm) 7 Accuracy symbol (page 10) 8 Symbol for joint LM rail 9 No. of LM rails used on the same plane

Note This model number indicates that a single-rail unit constitutes one set (i.e., required number of sets when 2 rails are used in parallel is 2 at a minimum).

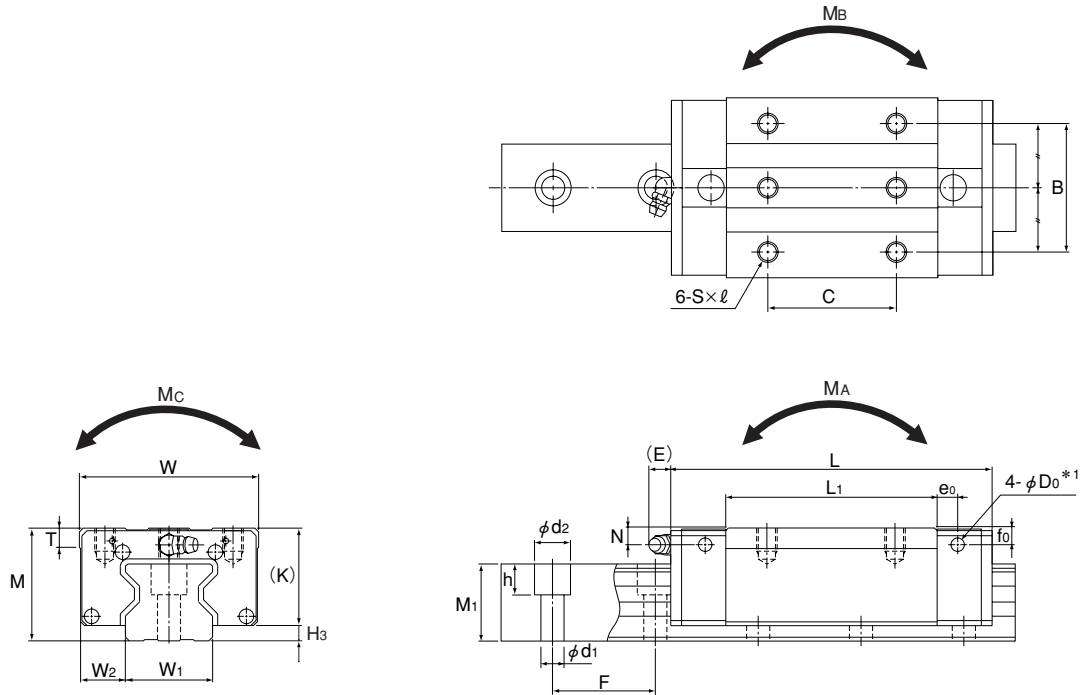

Models R/LR

Unit: mm

	LM rail dimensions						Basic load rating		Permissible static moment kN-m*3					Mass	
	Width W1 0 -0.05	W2	Height M1	Pitch F	d1 x d2 x h	Length Max*2	C [kN]	C0 [kN]	MA		MB		MC	LM block [kg]	LM rail [kg/m]
									1 block	Double blocks	1 block	Double blocks	1 block		
	34	33	30	40	9×14×12	3000	59.1	119	1.66	10.1	1.66	10.1	2.39	1.6	6.9
							76	165	3.13	17	3.13	17	3.31	2	
	34	18	30	40	9×14×12	3000	59.1	119	1.66	10.1	1.66	10.1	2.39	1.1	6.9
							76	165	3.13	17	3.13	17	3.31	1.4	
	45	37.5	36	52.5	14×20×17	3090	91.9	192	3.49	20	3.49	20	4.98	3	11.3
							115	256	6.13	32.2	6.13	32.2	6.64	3.6	
	45	20.5	36	52.5	14×20×17	3090	91.9	192	3.49	20	3.49	20	4.98	1.9	11.3
							115	256	6.13	32.2	6.13	32.2	6.64	2.5	
	53	43.5	43	60	16×23×20	3060	131	266	5.82	33	5.82	33	8.19	4.9	15.8
							167	366	10.8	57	10.8	57	11.2	6.4	
	53	23.5	43	60	16×23×20	3060	131	266	5.82	33	5.82	33	8.19	3.2	15.8
							167	366	10.8	57	10.8	57	11.2	4.5	
	63	53.5	49	75	18×26×22	3000	278	599	22.7	120	22.7	120	22.1	12.7	21.3
							278	599	22.7	120	22.7	120	22.1	9.4	

Note

*1 Pilot holes for side nipples are not drilled through in order to prevent foreign material from entering the product. THK will mount grease nipples per your request. Therefore, do not use the side nipple pilot holes for purposes other than mounting a grease nipple.

*2 The maximum length under "Length" indicates the standard maximum length of an LM rail.

*3 Permissible static moment: 1 block: permissible static moment value with 1 LM block
Double blocks: permissible static moment value with 2 blocks closely contacting with each other

SRG/SRN

Standard Length and Maximum Length of the LM Rail

The table below shows the standard length and the maximum length of the LM rail for models SRG/SRN. If the maximum length of the desired LM rail exceeds the corresponding value, connected rails will be used. Contact THK for details.

For the G dimension when a special length is required, we recommend selecting the corresponding G value from the table. The longer the G dimension, the less stable the G area may become after installation, thus adversely affecting the accuracy.

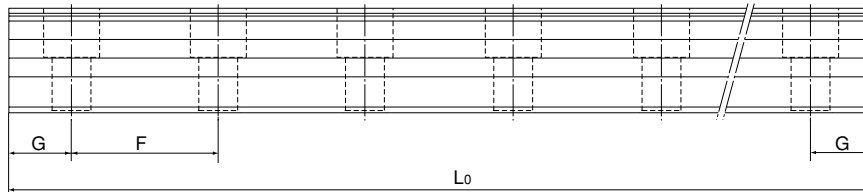

Standard Length and Maximum Length of the LM Rail for Models SRG/SRN

Unit: mm

Model No.	SRG15	SRG20	SRG 25	SRG 30	SRG/SRN 35	SRG/SRN 45	SRG/SRN 55	SRG/SRN 65
Standard LM rail length (L_0)	160	220	220	280	280	570	780	1270
	220	280	280	360	360	675	900	1570
	280	340	340	440	440	780	1020	2020
	340	400	400	520	520	885	1140	2620
	400	460	460	600	600	990	1260	
	460	520	520	680	680	1095	1380	
	520	580	580	760	760	1200	1500	
	580	640	640	840	840	1305	1620	
	640	700	700	920	920	1410	1740	
	700	760	760	1000	1000	1515	1860	
	760	820	820	1080	1080	1620	1980	
	820	940	940	1160	1160	1725	2100	
	940	1000	1000	1240	1240	1830	2220	
	1000	1060	1060	1320	1320	1935	2340	
	1060	1120	1120	1400	1400	2040	2460	
	1120	1180	1180	1480	1480	2145	2580	
	1180	1240	1240	1560	1560	2250	2700	
	1240	1360	1300	1640	1640	2355	2820	
	1360	1480	1360	1720	1720	2460	2940	
	1480	1600	1420	1800	1800	2565	3060	
1600	1720	1480	1880	1880	2670			
	1840	1540	1960	1960	2775			
	1960	1600	2040	2040	2880			
	2080	1720	2200	2200	2985			
	2200	1840	2360	2360	3090			
		1960	2520	2520				
		2080	2680	2680				
		2200	2840	2840				
		2320	3000	3000				
		2440						
Standard pitch F	30	30	30	40	40	52.5	60	75
G	20	20	20	20	20	22.5	30	35
Max Length	2500	3000	3000	3000	3000	3090	3060	3000

Note 1: The maximum length varies with accuracy grades. Contact THK for details.

Note 2: If connected rails are not allowed and a greater length than the maximum values above is required, contact THK.

SRG/SRN OPTIONS

Options

For models SRG/SRN, contamination protection and lubrication accessories are available. You can make a selection according to the application or mounting location.

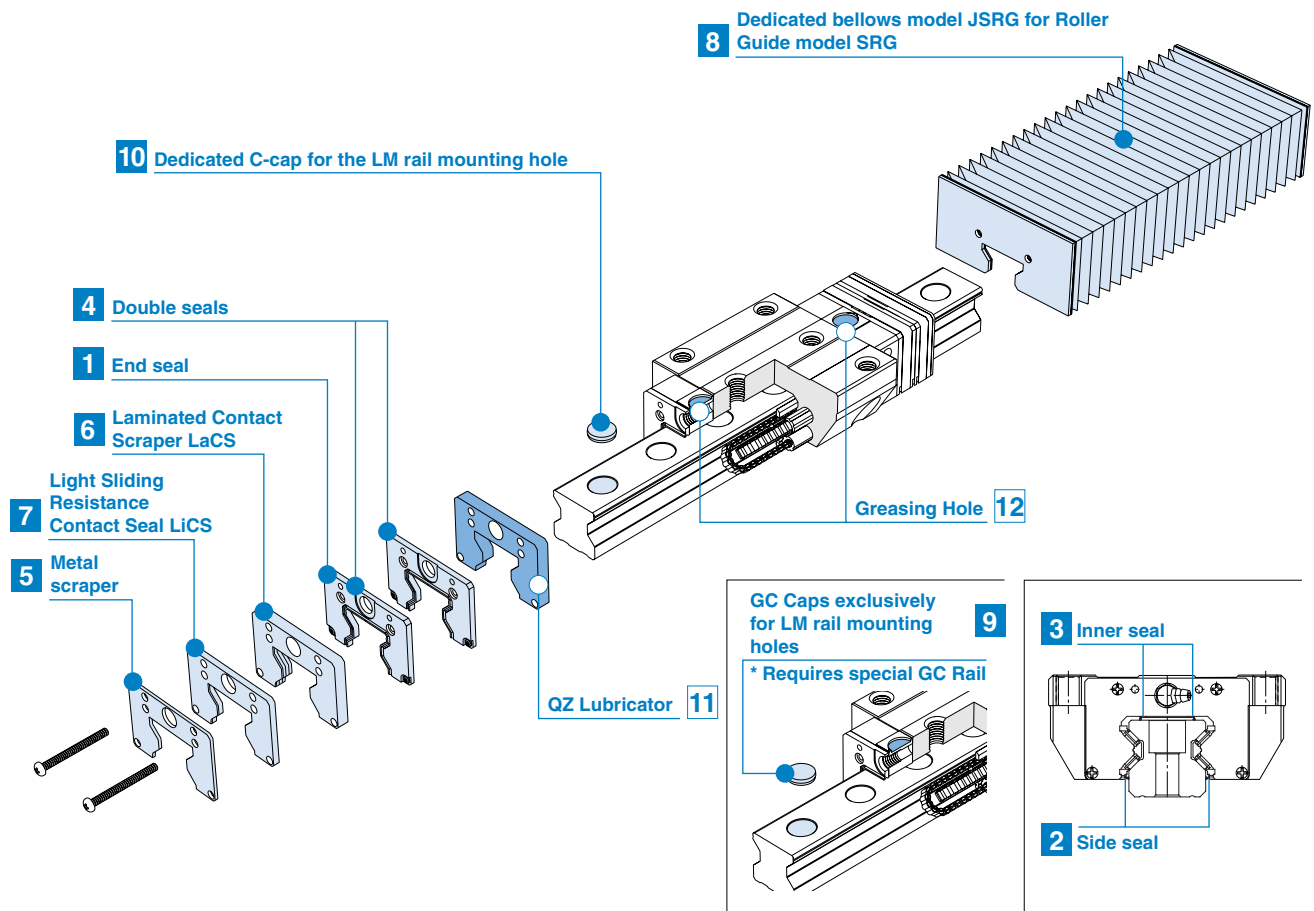

Contamination Protection Accessories

When foreign material enters an LM system, it will cause abnormal wear or shorten the service life, and it is necessary to prevent foreign material from entering the system. Therefore, when possible entry of foreign material is predicted, it is important to select an effective sealing device or contamination protection device that meets the atmospheric conditions.

1 End seal

Used in locations exposed to dust

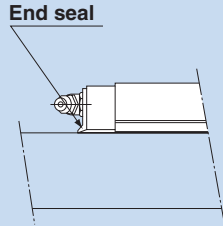

2 Side Seal

Used in locations where dust may enter the LM block from the side or bottom surface, such as vertical, horizontal and inverted mounts

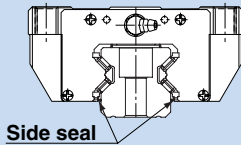

3 Inner seal

Used in locations severely exposed to dust or cutting chips

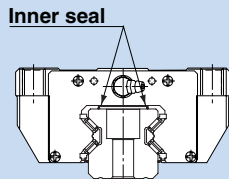

Seals and Scrapers

1 to 4 Seals

THK offers seals such as an end seal made of special synthetic rubber with high wear resistance and a side seal designed to increase the contamination protection effect.

When a contamination protection accessory is required, specify the desired item with the corresponding symbol provided in Table 3. For supported models for contamination protection accessories and a specific overall LM block length with a contamination protection accessory attached (dimension L), see Tables 4 and 5.

Seal resistance value

For the maximum seal resistance value per LM block when a lubricant is applied on seals for models SRG/SRN...SS, refer to the corresponding value provided in Table 1.

Table 1 Maximum Seal Resistance Value of Seals for models SRG/SRN...SS

Model No.	Seal resistance
SRG 15	13
SRG 20	18
SRG 25	19
SRG 30	24
SRG 35	30
SRG 45	30
SRG 55	35
SRG 65	40

The seal resistance values for models SRN 35 to 65 are equal to that of model SRG.

5 to 6 Scrapers

Laminated Contact Scraper LaCS®

For locations with an adverse atmosphere, Laminated Contact Scraper LaCS is available.

LaCS removes minute foreign material adhering to the LM rail in multiple stages and prevents it from entering the LM block with its laminated contact structure (3-layer scraper).

Features

- Since the 3 layers of scrapers fully contact the LM rail, LaCS is highly capable of removing minute foreign material.
- Since it uses oil-impregnated foam synthetic rubber with a self-lubricating function, low friction resistance is achieved.

Basic Specifications of LaCS

- Service temperature range of LaCS: -20°C to +80°C
- Maximum resistance for LaCS: see the table on the right.

Note: LaCS is not sold alone.

Table 2 Maximum resistance for LaCS

Model No.	Maximum resistance for LaCS
SRG 20	6.1
SRG 25	6.9
SRG 30	8.2
SRG 35	9.1
SRG 45	14.3
SRG 55	18.2
SRG 65	26.0
SRN 65	22.1

The resistances of LaCS for models SRN 35 to 55 are equal to that of model SRG.

Note 1: The indicated resistance values consist only of the resistance of LaCS and do not include sliding resistance of the LM block, seals and the likes.

Note 2: For the maximum service velocity of LaCS, contact THK.

7 Light Sliding Resistance Contact Seal LiCS

LiCS is a contact seal with a low sliding resistance. It is effective in removing dust and the like from the raceway and retaining a lubricant such as grease. With its very low sliding resistance, LiCS achieves a smooth and stable motion.

Table 3 Symbols of Contamination Protection Accessories for Models SRG/SRN

Symbol	Contamination protection accessories
UU	End seal
SS	End seal + side seal + inner seal
DD	End seal + side seal + inner seal
GG	LiCS
PP	LiCS + side seal + inner seal
ZZ	End seal + side seal + inner seal+ metal scraper
KK	Double seals + side seal + inner seal + metal scraper
SSHH	End seal + side seal + inner seal + LaCS
DDHH	Double seals + side seal + inner seal + LaCS
ZZHH	End seal + side seal + inner seal + metal scraper + LaCS
KKHH	Double seals + side seal + inner seal + metal scraper + LaCS

Note: Light Sliding Resistance Contact Seal LiCS (GG and PP) is available only for model SRG15.

For Models Attached with Contamination Protection Accessories SSHH, DDHH, ZZHH or KKHH

Models attached with contamination protection accessories SSHH, DDHH, ZZHH or KKHH have a grease nipple in the location indicated in the figure below. The table on the right shows incremental dimensions with the grease nipple.

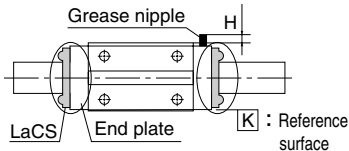

Note: When desiring the mounting location for the grease nipple other than the one indicated above, contact THK.

Unit: mm

Model No.	Incremental dimension with grease nipple H	Nipple type
SRG 25C/LC	—	A-M6F
SRG 25R/LR	7.2	A-M6F
SRG 30C/LC	—	A-M6F
SRG 30R/LR	7.2	A-M6F
SRG 35C/LC	—	A-M6F
SRG 35R/LR	7.2	A-M6F
SRG 45C/LC	—	A-M6F
SRG 45R/LR	7.2	A-M6F
SRG 55C/LC	—	A-M6F
SRG 55R/LR	7.2	A-M6F
SRG 65C/LC	—	A-M6F
SRG 65R/LR	6.2	A-M6F

For Models Attached with Contamination Protection Accessories UU or SS

For the mounting location of the grease nipple (N) and its incremental dimension (E) when contamination protection accessories UU or SS are attached, see the corresponding dimensional table (see page 13 to 18).

For Models Attached with Contamination Protection Accessories DD, ZZ or KK

For the mounting location of the grease nipple and its incremental dimension when contamination protection accessories DD, ZZ or KK are attached, contact THK.

Table 4 Overall LM Block Length (Dimension L) of Model SRG with a Contamination Protection Accessory Attached
Unit: mm

Model No.	UU	SS	DD	GG	PP	ZZ	KK	SSHH	DDHH	ZZHH	KKHH
SRG 15A/V	69.2	69.2	71.2	77	77	—	—	—	—	—	—
SRG 20A/V	86.2	86.2	88.2	—	—	89.6	91.6	105.2	107.2	107.6	109.6
SRG 20LA/LV	106.2	106.2	108.2	—	—	109.6	111.6	125.2	127.2	127.6	129.6
SRG 25C/R	95.5	95.5	100.5	—	—	100.5	105.5	115.3	120.3	117.7	122.7
SRG 25LC/LR	115.1	115.1	120.1	—	—	120.1	125.1	134.9	139.9	137.3	142.3
SRG 30C/R	111	111	118	—	—	116	123	130.8	137.8	133.2	140.2
SRG 30LC/LR	135	135	142	—	—	140	147	154.8	161.8	157.2	164.2
SRG 35C/R	125	125	132.8	—	—	131.4	139.2	148.6	156.4	151	158.8
SRG 35LC/LR	155	155	162.8	—	—	161.4	169.2	178.6	186.4	181	188.8
SRG 45C/R	155	155	164.2	—	—	162.2	171.4	182	191.2	185.2	194.4
SRG 45LC/LR	190	190	199.2	—	—	197.2	206.4	217	226.2	220.2	229.4
SRG 55C/R	185	185	194.2	—	—	192.2	201.4	212	221.2	215.2	224.4
SRG 55LC/LR	235	235	244.2	—	—	242.2	251.4	262	271.2	265.2	274.4
SRG 65LC/LV	303	303	314.2	—	—	311.4	322.6	335.4	346.6	338.6	349.8

Table 5 Overall LM Block Length (Dimension L) of Model SRN with a Contamination Protection Accessory Attached
Unit: mm

Model No.	UU	SS	DD	ZZ	KK	SSHH	DDHH	ZZHH	KKHH
SRN 35C/R	125	125	132.8	131.4	139.2	148.6	156.4	151	158.8
SRN 35LC/LR	155	155	162.8	161.4	169.2	178.6	186.4	181	188.8
SRN 45C/R	155	155	164.2	162.2	171.4	182	191.2	185.2	194.4
SRN 45LC/LR	190	190	199.2	197.2	206.4	217	226.2	220.2	229.4
SRN 55C/R	185	185	194.2	192.2	201.4	212	221.2	215.2	224.4
SRN 55LC/LR	235	235	244.2	242.2	251.4	262	271.2	265.2	274.4
SRN 65LC/LR	303	303	314.2	311.4	322.6	335.4	346.6	338.6	349.8

4 Double Seals

Used in locations exposed to much dust or many cutting chips

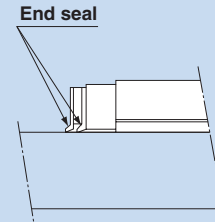

5 Metal Scraper

Used in locations where welding spatter may adhere to the LM rail

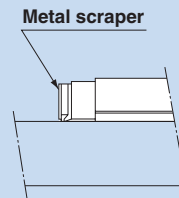

6 LaCS

Used in harsh environments exposed to foreign material such as fine dust and liquids

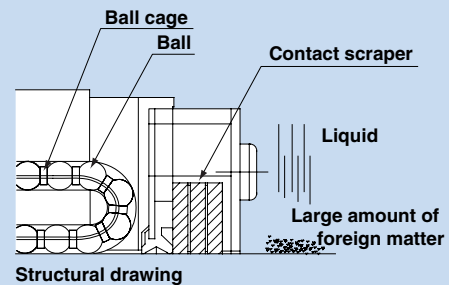

7 LiCS

Available only for model SRG 15

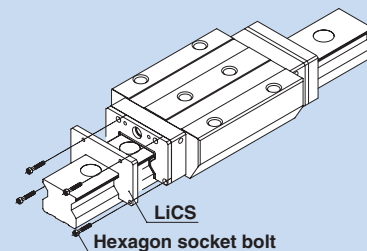

8 Dedicated Bellows JSRG for Model SRG

Used in locations exposed to much dust or many cutting chips

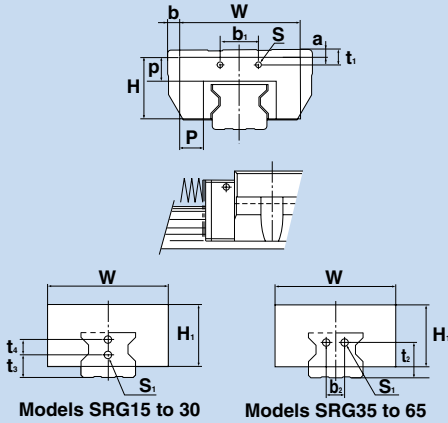

- Models SRG15 to 30** **Models SRG35 to 65**
- Note 1: When desiring to use the dedicated bellows other than in horizontal mount (i.e., vertical, wall and inverted mount), or when desiring a heat-resistant type of bellow, contact THK.
- Note 2: For lubrication when using the dedicated bellows, contact THK.
- Note 3: When using the dedicated bellows, the LM block and LM rail need to be machined so that the bellows can be mounted. Be sure to indicate that the dedicated bellows are required when placing an order.

Note: The bellows length is calculated as follows.

$$L_{min} = \frac{S}{(A-1)} \quad S: \text{Stroke length (mm)}$$

$$L_{max} = L_{min} \cdot A \quad A: \text{Extension rate}$$

9 GC Cap

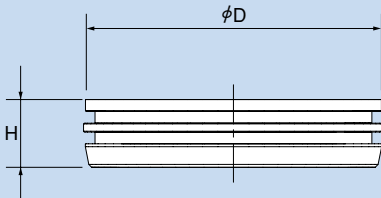

8 Dedicated Bellows JSRG for Model SRG

For locations with even worse working conditions, dedicated bellows are available. The table below shows the dimensions of the dedicated bellows. Specify the corresponding bellows model number shown below.

Dimensions of JSRG

Model No.	Main dimensions (mm)											Supported Roller Guide model	
	W	H	H ₁	P	p	b ₁	t ₁				t ₄		
							Type A/C	Type R/V	b ₂	t ₂			t ₃
JSRG 15	55	27	27	14.2	12.7	28	10.3	10.3	—	—	10.6	—	SRG 15
JSRG 20	66	32	32	17	15	38.5	9.6	9.6	—	—	7.4	8	SRG 20
JSRG 25	78	38	38	23	18	27.6	3.9	7.9	—	—	10	8	SRG 25
JSRG 30	84	42	42	22	19	37.4	10.4	13.4	—	—	11	10	SRG 30
JSRG 35	88	42	42	22	15	35	5	12	13	23	—	—	SRG 35
JSRG 45	100	51	51	20	20	32	7	17	15	29	—	—	SRG 45
JSRG 55	108	57	57	20	20	36	10	20	25	35	—	—	SRG 55
JSRG 65	132	75.5	75.5	28.5	25	46	9	9	28	42	—	—	SRG 65

Model No.	Main dimensions (mm)							Supported Roller Guide model
	Screw size		a		b		A L _{max} L _{min}	
	S	S ₁	Type A/C	Type R/V	Type A/C	Type R/V		
JSRG 15	M2	M4	7	7	4	10.5	5	SRG 15
JSRG 20	M2	M3	6.6	6.6	1.5	11	6	SRG 20
JSRG 25	M2	M3X6 ℓ	-6.5	-2.5	4	15	6	SRG 25
JSRG 30	M3	M4X8 ℓ	-5	-2	3	12	7	SRG 30
JSRG 35	M3	M4X4 ℓ	0	7	6	-9	5	SRG 35
JSRG 45	M3	M5X4 ℓ	0	10	10	-7	7	SRG 45
JSRG 55	M3	M5X4 ℓ	3	13	16	-4	7	SRG 55
JSRG 65	M4	M6X5 ℓ	3	3	19	-3	9	SRG 65

Example of model number coding JSRG35-60/420

- 1 Model number --- bellows for model SRG35
- 2 Bellows dimensions [length when compressed / length when extended]

9 Metal Cap Dedicated for LM Rail Mounting Holes GC Cap

GC cap is a metallic cap that plugs the LM rail mounting hole (article compliant with the RoHS Directives). It prevents the entrance of foreign material and coolant from the LM rail top face (mounting hole) under harsh environments, and significantly increases the dust control performance of the LM Guide if used with a dust control seal.

Unit: mm

Model No.	Outer diameter D	Thickness H	Model No.	Outer diameter D	Thickness H
GC5	9.86	2.5	GC14	23.36	5.0
GC6	11.36	2.5	GC16	26.36	5.0
GC8	14.36	3.5	GC22	35.36	5.0
GC10	17.86	3.5	GC24	39.36	5.0
GC12	20.36	4.6			

If designating an LM Guide model attached with GC cap, observe the following example of model number coding.

Example of model number coding

SRG45 LR 2 QZ KKHH C0 +1200L P T - II GC

Model number	No. of LM blocks used on the same rail	Symbol for contamination protection accessory (see page 22)	LM rail length (in mm)	No. of LM rails used on the same plane	With GC cap
Type of LM block	With QZ Lubricator attached	Radial clearance symbol (see page 9)	Accuracy symbol (page 10)		

- Note 1: The LM rail of an LM Guide model attached with GC cap is of special type.
- Note 2: GC cap cannot be mounted on an LM rail made of stainless steel or provided with surface treatment.
- Note 3: If using the product in a special environment such as vacuum, low temperature or high temperature, contact THK.
- Note 4: GC cap is not sold alone. It is always provided in combination with LM Guide.
- Note 5: The mouth of the LM rail mounting hole is not chamfered. Take care not to hurt your hand when attaching GC cap.
- Note 6: After attaching GC cap, be sure to level and clean (wipe off) the top face of the LM rail.

10 Dedicated Cap “C” for LM Rail Mounting Holes

If any of the LM rail mounting holes of an LM Guide is filled with cutting chips of foreign material, they may enter the LM block structure. Entry of such foreign material can be prevented by covering each LM rail mounting hole with the dedicated cap so that the top of the mounting holes are on the same level as the LM rail top face.

Since the dedicated cap “C” for LM rail mounting holes uses a special synthetic resin with high oil resistance and high wear resistance, it is highly durable. When placing an order, specify the desired cap type with the corresponding cap number indicated in the table on the right.

Main Dimensions of the Dedicated Cap

Model No.	Cap “C” model No.	Bolt used	Main dimensions (mm)	
			D	H
15	C 4	M 4	7.8	1.0
20	C 5	M 5	9.8	2.4
25	C 6	M 6	11.4	2.7
30	C 8	M 8	14.4	3.7
35	C 8	M 8	14.4	3.7
45	C12	M12	20.5	4.7
55	C14	M14	23.5	5.7
65	C16	M16	26.5	5.7

Note: The main dimensions of the dedicated cap for models SRN 35 to 65 are the same as that of model SRG.

Dedicated Cap “C” for LM Rail Mounting Holes

10

Prevents cutting chips from entering the LM rail mounting holes

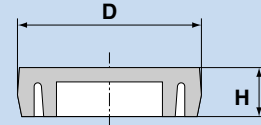

Removing/mounting Jig

When assembling the guide, do not remove the LM block from the LM rail whenever possible. If it is inevitable to remove the LM block due to the assembly procedure, be sure to use the removing/mounting jig.

Mounting the LM block without using the removing/mounting jig may lead some of the rolling elements to fall off from the LM block due to entry of foreign material, damage to internal parts or slight inclination. In addition, using the LM block with some of the rolling elements missing will cause the LM system to be damaged early. Be sure to use the removing/mounting jig. When using the removing/mounting jig, do not incline the jig, and match the end of the jig with that of the LM block. If any of the rolling elements falls off from the LM block, do not use the product, and be sure to contact THK. The removing/mounting jig is not provided as standard. When desiring to use it, contact THK.

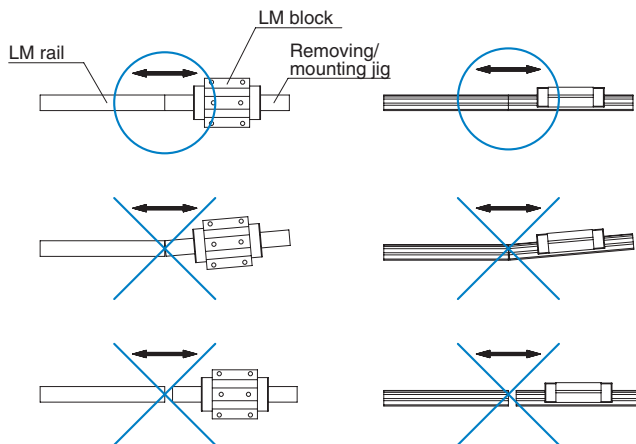

Removing/mounting jig

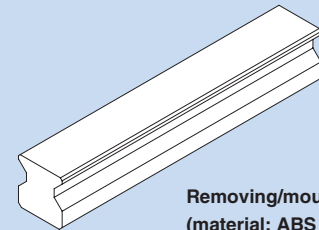

Removing/mounting jig
(material: ABS resin)

Lubrication Related Accessories

11 QZ Lubricator

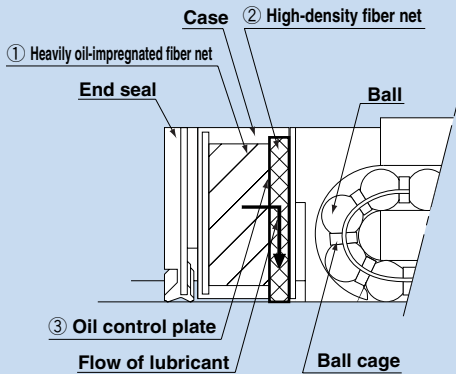

The structure of the QZ Lubricator consists of three major components:

- ① A heavy oil-impregnated fiber net (functions to store lubricant).
- ② A high-density fiber net (functions to apply lubricant to the raceway).
- ③ An oil-control plate (functions to control the flow of the lubricant).

The lubricant contained in the QZ Lubricator is fed to the LM system based on the principle of capillary action, which is used in felt-tip pens and other products.

11 QZ Lubricator™

The QZ Lubricator feeds a right amount of lubricant to the raceway of the LM rail. This allows an oil film to be constantly formed between the rolling elements and the ball raceway, thus significantly extending the lubrication maintenance interval.

When the QZ Lubricator is required, specify the desired type with the corresponding symbol indicated in Table 1. For supported LM Guide models for the QZ Lubricator and the overall LM block length with the QZ Lubricator attached (dimension L), see Table 2, 3.

Features

- Since it supplements an oil loss, the lubrication maintenance interval can significantly be extended.
- Since the right amount of lubricant is applied to the ball raceway, an environmentally friendly lubrication system that does not contaminate the surroundings is achieved.
- It allows the user to select a lubricant that meets the intended use.

Significantly Extended Maintenance Interval

Attaching the QZ Lubricator helps extend the maintenance interval throughout the whole load range from the light-load area to the heavy-load area.

Note 1: The QZ Lubricator is not sold alone.

Note 2: Those LM Guide models attached with the QZ Lubricator cannot have a grease nipple. When desiring both the QZ Lubricator and a grease nipple to be attached, contact THK.

Table 1 Parts Symbols for Model SRG with the QZ Lubricator Attached

Symbol	Contamination protection accessories with the QZ Lubricator attached
QZUU	End seal + QZ
QZSS	End seal + side seal + inner seal + QZ
QZDD	Double seals + side seal + inner seal + QZ
QZGG	LiCS + QZ
QZPP	LiCS + side seal + inner seal + QZ
QZZZ	End seal + side seal + inner seal + metal scraper + QZ
QZKK	Double seals + side seal + inner seal + metal scraper + QZ
QZSSH	End seal + side seal + inner seal + LaCS + QZ
QZDDH	Double seals + side seal + inner seal + LaCS + QZ
QZZZH	End seal + side seal + inner seal + metal scraper + LaCS + QZ
QZKHH	Double seals + side seal + inner seal + metal scraper + LaCS + QZ

Note: Light Sliding Resistance Contact Seal LiCS (QZGG and QZPP) is available only for model SRG 15.

Table 2 Overall LM Block Length (Dimension L) of Model SRG with the QZ Lubricator Attached
Unit: mm

Model No.	QZUU	QZSS	QZDD	QZGG	QZPP	QZZZ	QZKK	QZSSH	QZDDH	QZZZH	QZKHH
SRG 15A/V	90.6	90.6	92.6	97	97	—	—	—	—	—	—
SRG 20A/V	107.6	107.6	109.6	—	—	111	113	125.2	127.2	127.6	129.6
SRG 20LA/LV	127.6	127.6	129.6	—	—	131	133	145.2	147.2	147.6	149.6
SRG 25C/R	125.5	125.5	130.5	—	—	130.5	135.5	145.3	151.7	147.7	154.1
SRG 25LC/LR	145.1	145.1	150.1	—	—	150.1	155.1	164.9	171.3	167.3	173.7
SRG 30C/R	141	141	148	—	—	146	153	160.8	169.2	164.6	171.6
SRG 30LC/LR	165	165	172	—	—	170	177	184.8	193.2	188.6	195.6
SRG 35C/R	155	155	162.8	—	—	163.4	171.2	178.6	186.4	181	188.8
SRG 35LC/LR	185	185	192.8	—	—	193.4	201.2	208.6	216.4	211	218.8
SRG 45C/R	185	185	194.2	—	—	194.2	203.4	212	221.2	215.2	224.4
SRG 45LC/LR	220	220	229.2	—	—	229.2	238.4	247	256.2	250.2	259.4
SRG 55C/R	225	225	234.2	—	—	234.2	243.4	252	261.2	255.2	264.4
SRG 55LC/LR	275	275	284.2	—	—	284.2	293.4	302	311.2	305.2	314.4
SRG 65LC/LV	343	343	354.2	—	—	354.2	370.4	380.4	391.6	378.6	389.8

Table 3 Overall LM Block Length (Dimension L) of Model SRN with the QZ Lubricator Attached
Unit: mm

Model No.	QZUU	QZSS	QZDD	QZZZ	QZKK	QZSSH	QZDDH	QZZZH	QZKHH
SRN 35C/R	155	155	162.8	163.4	171.2	178.6	186.4	181	188.8
SRN 35LC/LR	185	185	192.8	193.4	201.2	208.6	216.4	211	218.8
SRN 45C/R	185	185	194.2	194.2	203.4	212	221.2	215.2	224.4
SRN 45LC/LR	220	220	229.2	229.2	238.4	247	256.2	250.2	259.4
SRN 55C/R	225	225	234.2	234.2	243.4	252	261.2	255.2	264.4
SRN 55LC/LR	275	275	284.2	284.2	293.4	302	311.2	305.2	314.4
SRN 65LC/LR	343	343	354.2	354.2	370.4	380.4	391.6	378.6	389.8

12 Greasing Hole

Models SRG/SRN allow lubrication from both the side and top faces of the LM block. The greasing hole of standard types is not drilled through in order to prevent foreign material from entering the LM block. When using the greasing hole, contact THK.

The greasing interval is longer than full-roller type LM Guides thanks to the roller cage effect. However, the greasing interval varies according to the service environment such as a heavy load and high speeds. Contact THK for details.

Unit: mm

Model No.	Pilot hole for side nipple			Applicable nipple	Greasing hole on the top face		
	e_o	f_o	D_o		D2 (O-ring)	V	e_i
SRG15A SRG15V	4	6	2.9	PB107	9.2(P6)	0.5	5.5
SRG20A/LA	4	6	2.9	PB107	9.2(P6)	0.5	6.5
SRG20V/LV	4	6	2.9	PB107	9.2(P6)	0.5	6.5
SRG 25C SRG 25LC	6	6.4	5.2	M6F	10.2(P7)	0.5	6
SRG 25R SRG 25LR	6	10.4	5.2	M6F	10.2(P7)	4.5	6
SRG 30C SRG 30LC	6	6.2	5.2	M6F	10.2(P7)	0.4	6
SRG 30R SRG 30LR	6	9.2	5.2	M6F	10.2(P7)	3.4	6
SRG 35C SRG 35LC	6	6	5.2	M6F	10.2(P7)	0.4	6
SRG 35R SRG 35LR	6	13	5.2	M6F	10.2(P7)	7.4	6
SRG 45C SRG 45LC	7	7	5.2	M6F	10.2(P7)	0.4	7
SRG 45R SRG 45LR	7	17	5.2	M6F	10.2(P7)	10.4	7
SRG 55C SRG 55LC	9	8.5	5.2	M6F	10.2(P7)	0.4	11
SRG 55R SRG 55LR	9	18.5	5.2	M6F	10.2(P7)	10.4	11
SRG 65LC	9	13.5	5.2	M6F	10.2(P7)	0.4	10
SRG 65LV	9	13.5	5.2	M6F	10.2(P7)	0.4	10

Note: When using the greasing hole on the top face of models SRG-R and SRG-LR, a greasing adapter is separately required. Contact THK for details.

Unit: mm

Model No.	Pilot hole for side nipple			Applicable nipple	Greasing hole on the top face		
	e_o	f_o	D_o		D2 (O-ring)	V	e_i
SRN 35C SRN 35LC	8	6.5	5.2	M6F	10.2(P7)	0.4	6
SRN 35R SRN 35LR	8	6.5	5.2	M6F	10.2(P7)	0.4	6
SRN 45C SRN 45LC	8.5	7	5.2	M6F	10.2(P7)	0.4	7
SRN 45R SRN 45LR	8.5	7	5.2	M6F	10.2(P7)	0.4	7
SRN 55C SRN 55LC	10	8	5.2	M6F	10.2(P7)	0.4	11
SRN 55R SRN 55LR	10	8	5.2	M6F	10.2(P7)	0.4	11
SRN 65LC	9	11	5.2	M6F	10.2(P7)	0.4	10
SRN 65LR	9	11	5.2	M6F	10.2(P7)	0.4	10

Greasing hole

12

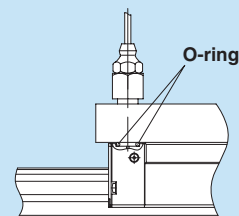
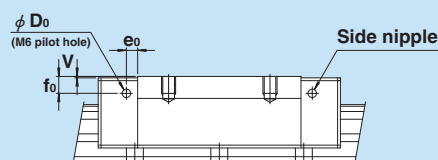
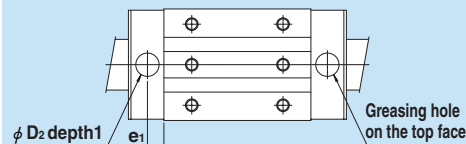

Method for using the greasing hole on the top face

THK Caged Roller LM Guide SRG/SRN

Precautions on use

● Handling

- Disassembling components may cause dust to enter the system or degrade mounting accuracy of parts. Do not disassemble the product.
- Tilting an LM block or LM rail may cause them to fall by their own weight.
- Dropping or hitting the LM Guide may damage it. Giving an impact to the LM Guide could also cause damage to its function even if the guide looks intact.

● Lubrication

- Thoroughly remove anti-corrosion oil and feed lubricant before using the product.
- Do not mix lubricants of different physical properties.
- In locations exposed to constant vibrations or in special environments such as clean rooms, vacuum and low/high temperature, normal lubricants may not be used. Contact THK for details.
- When planning to use a special lubricant, contact THK before using it.
- When adopting oil lubrication, the lubricant may not be distributed throughout the LM system depending on the mounting orientation of the system. Contact THK for details.
- Lubrication interval varies according to the service conditions. Contact THK for details.

● Precautions on Use

- Entrance of foreign matter may cause damage to the ball circulating path or functional loss. Prevent foreign matter, such as dust or cutting chips, from entering the system.
- When planning to use the LM system in an environment where coolant penetrates the LM block, it may cause trouble to product functions depending on the type of coolant. Contact THK for details.
- Do not use the LM system at temperature of 80°C or higher. When desiring to use the system at temperature of 80°C or higher, contact THK in advance.
- If foreign matter adheres to the LM system, replenish the lubricant after cleaning the product. For available types of detergent, contact THK.
- When using the LM Guide with an inverted mount, breakage of the endplate due to an accident or the like may cause balls to fall out and the LM block to come off from the LM rail and fall. In these cases, take preventive measures such as adding a safety mechanism for preventing such falls.
- When using the LM system in locations exposed to constant vibrations or in special environments such as clean rooms, vacuum and low/high temperature, contact THK in advance.
- When removing the LM block from the LM rail and then replacing the block, an LM block mounting/removing jig that facilitates such installation is available. Contact THK for details.

● Storage

- When storing the LM Guide, enclose it in a package designated by THK and store it in a horizontal orientation while avoiding high temperature, low temperature and high humidity.

● “LM GUIDE,” and “” are registered trademarks of THK CO., LTD.

- The photo may differ slightly in appearance from the actual product.
 - The appearance and specifications of the product are subject to change without notice. Contact THK before placing an order.
 - Although great care has been taken in the production of this catalog, THK will not take any responsibility for damage resulting from typographical errors or omissions.
 - For the export of our products or technologies and for the sale for exports, THK in principle complies with the foreign exchange law and the Foreign Exchange and Foreign Trade Control Law as well as other relevant laws.
- For export of THK products as single items, contact THK in advance.

All rights reserved

THK CO., LTD.

HEAD OFFICE 3-11-6, NISHI-GOTANDA, SHINAGAWA-KU, TOKYO 141-8503 JAPAN
INTERNATIONAL SALES DEPARTMENT PHONE:+81-3-5434-0351 FAX:+81-3-5434-0353

Global site : <http://www.thk.com/>

NORTH AMERICA

THK America, Inc.

● HEADQUARTERS

Phone:+1-847-310-1111 Fax:+1-847-310-1271

● CHICAGO OFFICE

Phone:+1-847-310-1111 Fax:+1-847-310-1182

● NORTH EAST OFFICE

Phone:+1-845-369-4035 Fax:+1-845-369-4909

● ATLANTA OFFICE

Phone:+1-770-840-7990 Fax:+1-770-840-7897

● LOS ANGELES OFFICE

Phone:+1-949-955-3145 Fax:+1-949-955-3149

● SAN FRANCISCO OFFICE

Phone:+1-925-455-8948 Fax:+1-925-455-8965

● DETROIT OFFICE

Phone:+1-248-858-9330 Fax:+1-248-858-9455

● TORONTO OFFICE

Phone:+1-905-820-7800 Fax:+1-905-820-7811

SOUTH AMERICA

THK Brasil LTDA

Phone:+55-11-3767-0100 Fax:+55-11-3767-0101

EUROPE

THK GmbH

● EUROPEAN HEADQUARTERS

Phone:+49-2102-7425-555 Fax:+49-2102-7425-556

● DÜSSELDORF OFFICE

Phone:+49-2102-7425-0 Fax:+49-2102-7425-299

● FRANKFURT OFFICE

Phone:+49-2102-7425-650 Fax:+49-2102-7425-699

● STUTTGART OFFICE

Phone:+49-7150-9199-0 Fax:+49-7150-9199-888

● MÜNCHEN OFFICE

Phone:+49-8937-0616-0 Fax:+49-8937-0616-26

● U.K. OFFICE

Phone:+44-1908-30-3050 Fax:+44-1908-30-3070

● ITALY MILANO OFFICE

Phone:+39-039-284-2079 Fax:+39-039-284-2527

● ITALY BOLOGNA OFFICE

Phone:+39-051-641-2211 Fax:+39-051-641-2230

● SWEDEN OFFICE

Phone:+46-8-445-7630 Fax:+46-8-445-7639

● AUSTRIA OFFICE

Phone:+43-7229-51400 Fax:+43-7229-51400-79

● SPAIN OFFICE

Phone:+34-93-652-5740 Fax:+34-93-652-5746

● TURKEY OFFICE

Phone:+90-216-362-4050 Fax:+90-216-569-7150

● PRAGUE OFFICE

Phone:+420-2-41025-100 Fax:+420-2-41025-199

● MOSCOW OFFICE

Phone:+7-495-649-80-47 Fax:+7-495-649-80-44

THK Europe B.V.

● EINDHOVEN OFFICE

Phone:+31-040-290-9500 Fax:+31-040-290-9599

THK France S.A.S.

Phone:+33-4-3749-1400 Fax:+33-4-3749-1401

CHINA

THK (CHINA) CO.,LTD.

● HEADQUARTERS

Phone:+86-411-8733-7111 Fax:+86-411-8733-7000

● SHANGHAI OFFICE

Phone:+86-21-6219-3000 Fax:+86-21-6219-9890

● BEIJING OFFICE

Phone:+86-10-8441-7277 Fax:+86-10-6590-3557

● CHENGDU OFFICE

Phone:+86-28-8526-8025 Fax:+86-28-8525-6357

● GUANGZHOU OFFICE

Phone:+86-20-8523-8418 Fax:+86-20-3801-0456

THK (SHANGHAI) CO.,LTD.

Phone:+86-21-6275-5280 Fax:+86-21-6219-9890

TAIWAN

THK TAIWAN CO.,LTD.

● TAIPEI HEAD OFFICE

Phone:+886-2-2888-3818 Fax:+886-2-2888-3819

● TAICHUNG OFFICE

Phone:+886-4-2359-1505 Fax:+886-4-2359-1506

● TAINAN OFFICE

Phone:+886-6-289-7668 Fax:+886-6-289-7669

KOREA

SEOUL REPRESENTATIVE OFFICE

Phone:+82-2-3468-4351 Fax:+82-2-3468-4353

SINGAPORE

THK LM SYSTEM Pte. Ltd.

Phone:+65-6884-5500 Fax:+65-6884-5550

INDIA

BANGALORE REPRESENTATIVE OFFICE

Phone:+91-80-2330-1524 Fax:+91-80-2314-8226

