

THK



NEW

Wide Caged-roller LM Guide

Optimal for large machines that require high rigidity and mounting accuracy

Ultra-high rigidity, heavy load

A wide, large roller guide model is added to the lineup

SRW130,150

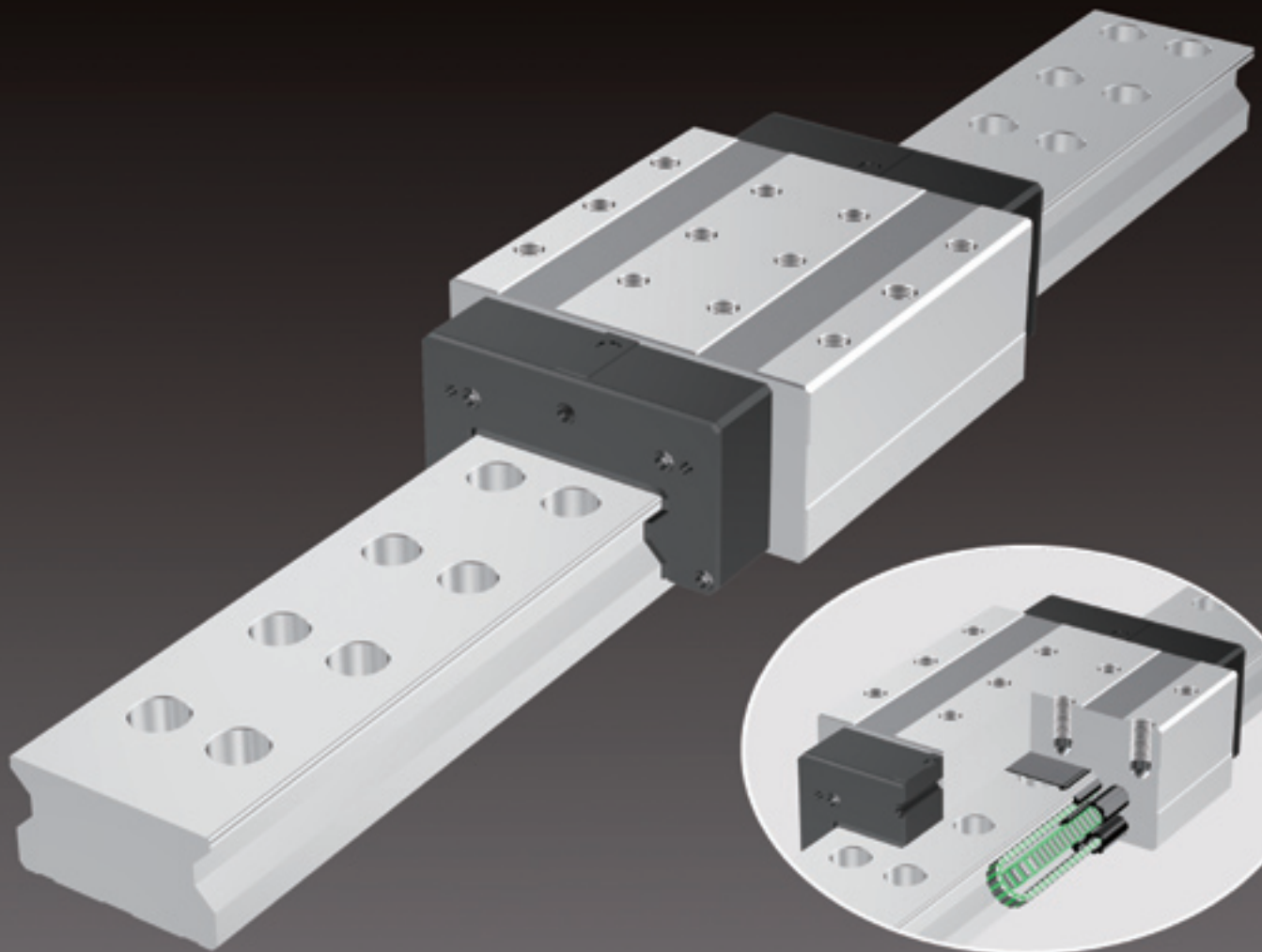

THK CO., LTD.
TOKYO. JAPAN

CATALOG No.347E

Wide Caged-roller LM Guide

SRW130,150

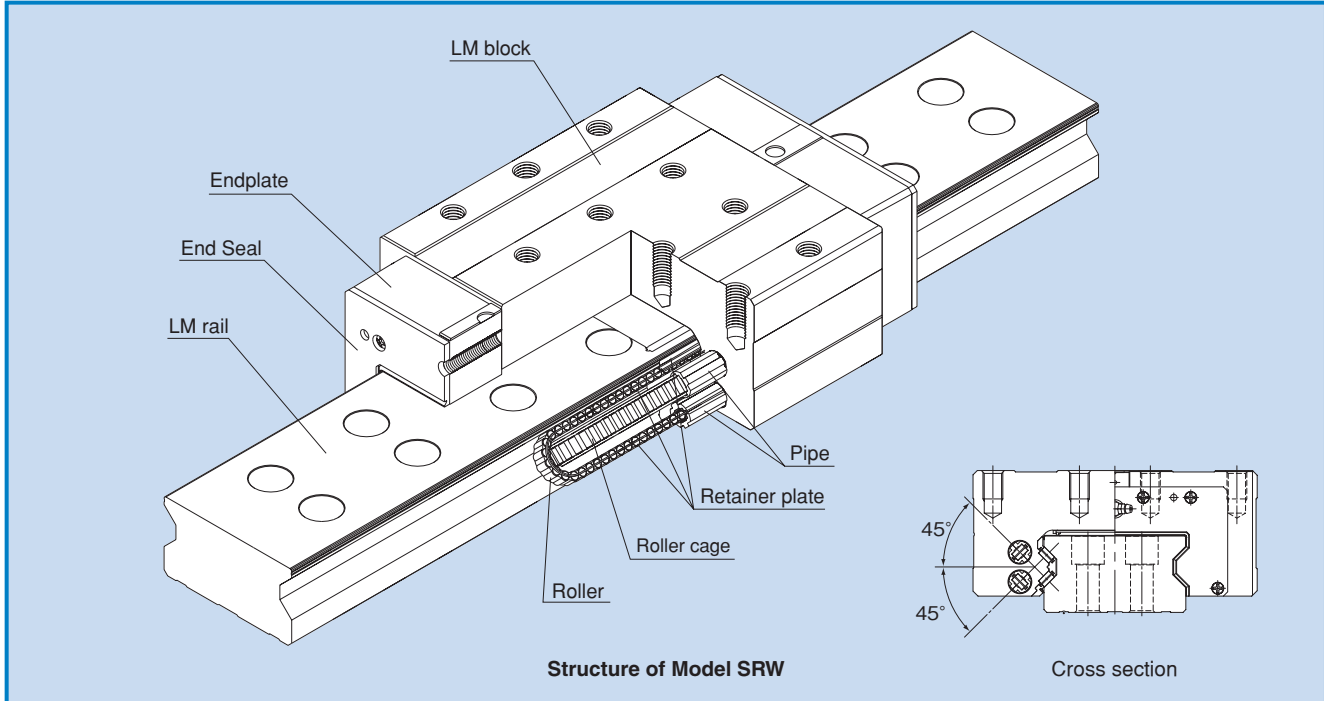

Model SRW is a wide, ultra-high rigidity Roller Guide that has an LM rail wider than that of caged-roller LM Guide model SRW and is equipped with two rows of rail mounting holes to increase the mounting strength and the mounting stability. In addition, it uses roller cages to prevent rollers from skewing, thus allowing low-friction, smooth motion and achieve long-term maintenance-free operation.

Features

● Ultra-high Rigidity

Since its wide rail can be secured with two rows of mounting bolts, the mounting strength is increased. In addition, since the raceway distance (L) in the width direction is large, this model has a strong structure against the moment load (moment M_c) in the rolling direction. For the rolling elements, this model uses highly rigid rollers*.

*The overall roller length is more than 1.5 times the roller diameter.

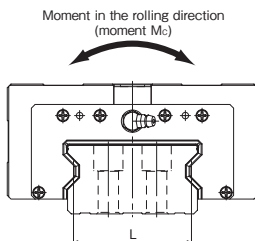

● Smooth Motion through Skewing Prevention

The roller cage allows rollers to form an evenly spaced line while recirculating, thus preventing the rollers from skewing (tilt of rollers) as the block enters a loaded area. As a result, fluctuation of the rolling resistance is minimized and smooth stable motion is achieved.

● 4-way Equal Load

Since each row of rollers is arranged at a contact angle of 45° so that the LM block receives an equal load rating in all four directions (radial, reverse radial and lateral directions), high rigidity is ensured in all directions.

● Long-term Maintenance-free Operation

Use of the roller cage eliminates friction between rollers and enables the lubricant to be retained in grease pockets formed between adjacent rollers. As the rollers recirculate, the grease pocket serves to provide the adequate amount of lubricant to achieve long-term maintenance-free operation.

Rated Load and Service Life

Calculating the Service Life

The service life of model SRW is obtained using the following equation.

$$L = \left(\frac{f_t \cdot f_c}{f_w} \cdot \frac{C}{P_c} \right)^{\frac{10}{3}} \times 100$$

L : Nominal life [km]
 (The total travel distance that 90% of a group of identical LM Guide units independently operating under the same conditions can achieve without showing flaking)

C : Basic dynamic load rating [N]
 P_c : Calculated load [N]
 f_t : Temperature Factor (see General Catalog)
 f_c : Contact factor (see General Catalog)
 f_w : Load Factor (see General Catalog)

$$L_h = \frac{L \times 10^6}{2 \times \ell_s \times n_1 \times 60}$$

L_h : Service life time [h]
 ℓ_s : Stroke length [mm]
 n_1 : Number of reciprocations per minute [min⁻¹]

Load Rating

Model SRW is capable of receiving loads in all directions: radial, reverse-radial and lateral directions.

The basic load ratings are uniform in the four directions (radial, reverse-radial and lateral directions), and their values are provided in the dimensional table (see P.5).

Equivalent Load

When the LM block of model SRW receives loads in all directions simultaneously, the equivalent load is obtained from the equation below.

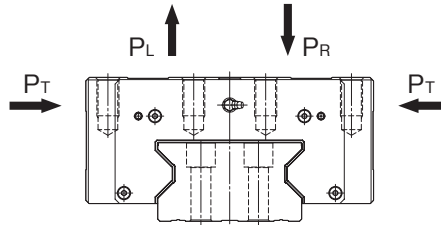

$$P_E = P_R (P_L) + P_T$$

P_E :Equivalent load [N]
 • Radial direction
 • Reverse radial direction
 • Lateral direction
 P_R :Radial load [N]
 P_L :Reverse radial load [N]
 P_T :Lateral load [N]

Equivalent moment factor

If a moment load is applied when a single LM block is used, or two LM blocks are used in close contact with each other, convert the moment load to an equivalent load by multiplying the moment load with the moment equivalent factor indicated in Table 1. See the General Catalog – Technical Descriptions of the Products for details.

$$P = K \cdot M$$

P :Equivalent load per LM Guide [N]
 K :Equivalent moment factor (see table 1)
 M :Applied moment [N-mm]

Table 1 Equivalent moment factor

Model No.	Equivalent factor							
	K_{AR1}	K_{AL1}	K_{AR2}	K_{AL2}	K_{B1}	K_{B2}	K_{CR}	K_{CL}
SRW 130LR	2.19×10^{-2}		4.15×10^{-3}		2.19×10^{-2}	4.15×10^{-3}	1.33×10^{-2}	
SRW 150LR	1.95×10^{-2}		3.67×10^{-3}		1.95×10^{-2}	3.67×10^{-3}	1.15×10^{-2}	

K_{AR1} : Equivalent factor in the M_A radial direction when one LM block is used
 K_{AL1} : Equivalent factor in the M_A reverse radial direction when one LM block is used
 K_{AR2} : Equivalent factor in the M_A radial direction when two LM blocks are used in close contact with each other
 K_{AL2} : Equivalent factor in the M_A reverse radial direction when two LM blocks are used in close contact with each other

K_{B1} : Equivalent factor in the M_B radial direction when one LM block is used
 K_{B2} : Equivalent factor in the M_B radial direction when two LM blocks are used in close contact with each other
 K_{CR} : M_C Equivalent factor in the radial direction
 K_{CL} : M_C Equivalent factor in the reverse radial direction

Accuracy Standards

For the accuracy of model SRW, running parallelism, dimensional tolerance in height and width, and difference in height and width required when multiple LM blocks are used on one rail or multiple rails are used on the same plane, are defined as indicated in the table below.

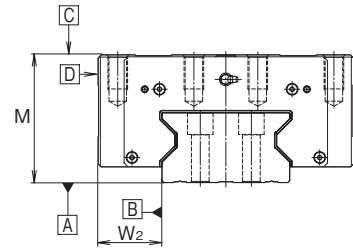

- **Running of parallelism**
See the General Catalog for details.
- **Difference in height M**
See the General Catalog for details.
- **Difference in Width W_2**
See the General Catalog for details.

Model No.	Accuracy Standards	Precision grade	Super precision grade	Ultra precision grade
	Item	P	SP	UP
130 100	Dimensional tolerance in height M	0 -0.05	0 -0.04	0 -0.03
	Difference in height M	0.01	0.007	0.005
	Dimensional tolerance in width W_2	0 -0.05	0 -0.04	0 -0.03
	Difference in width W_2	0.01	0.007	0.005
	Running parallelism of surface C against surface A	as shown in the table below		
	Running parallelism of surface D against surface B	as shown in the table below		

Unit:mm

LM Rail Length and Running Parallelism for Model SRW

LM rail length (mm)		Running Parallelism Values		
Above	Or less	Precision grade	Super precision grade	Ultra precision grade
		P	SP	UP
1250	1600	8	5	4
1600	2000	8.5	5.5	4.5
2000	2500	9.5	6	5
2500	3150	11	6.5	5.5
3150	4000	12	7.5	6
4000	5000	13	8.5	6.5

Unit: μ m

Note: For the running parallelism with the LM rail length exceeding the maximum value, contact THK.

Radial clearance

The table below shows the radial clearance of model SRW.

Model No.	Indication symbol		
	Normal No Symbol	Light preload C1	Medium preload C0
SRW 130LR	- 3 to - 1	- 7 to - 3	- 12 to - 7
SRW 150LR	- 3 to - 1	- 8 to - 3	- 13 to - 8

Unit: μ m

Note: If desiring normal clearance, add no symbol; for Light or Medium preload, indicate "C1" or "C0" in the model number. See the example of model number coding (see P.5) for details.

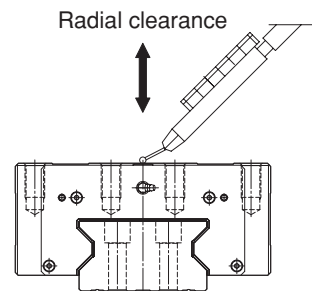

Shoulder Height of the Mounting Base and the Shape of the Corner

For the shoulder height of the mounting base for the LM block and the LM rail, we recommend using the value indicated in the table below. For the corner of the mounting base, secure a recess, or machine the corner to have a radius at or below the r_1 or r_2 value shown in the table below, so that the corner will not interfere with the chamfers of the LM block and the LM rail.

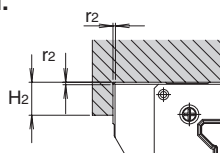

Shoulder for the LM block

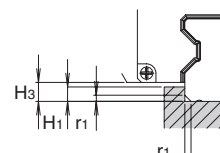

Shoulder for the LM rail

Model No.	Corner radius (Shoulder for the LM rail) r_1 (Max.)	Corner radius (Shoulder for the LM block) r_2 (Max.)	Shoulder height (Shoulder for the LM rail) H_1	Shoulder height (Shoulder for the LM block) H_2	H_3
SRW 130LR	1.5	1.5	12	14	16
SRW 150LR	2.0	2.0	12	16	16

Unit:mm

Accuracy of the Mounting Surface

Model SRW is highly rigid since it uses rollers as its rolling elements, and the roller cage prevents the rollers from skewing (tilt). However, the mounting surface needs to be machined with high accuracy. If the error on the mounting surface is high, it will affect the rolling resistance and the service life. Therefore, for the accuracy of the mounting surface, do not exceed the maximum permissible value (limit value) that corresponds to the radial clearance indicated in the table below.

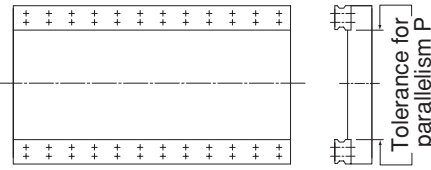

Error Allowance in Parallelism (P) between Two Rails

Unit:mm

Model No.	Radial clearance	Normal	C1	C0
SRW 130LR		0.026	0.018	0.014
SRW 150LR		0.030	0.021	0.016

Error Allowance in Level (X) between the Rails

Unit:mm

Radial clearance	Normal	C1	C0
Permissible error on the mounting surface X	0.00020a	0.00014a	0.00072a

$$X = X_1 + X_2$$

X₁: Level difference on the rail mounting surface

X₂: Level difference on the block mounting surface

Example of Calculation

When the rail span : a=500mm

$$\text{Permissible error on the mounting surface } X = 0.0003 \times 500 = 0.15$$

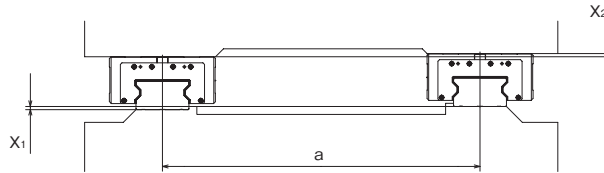

Error Allowance in Level (Y) in the Axial Direction

Unit:mm

Permissible error on the mounting surface	0.000036b
---	-----------

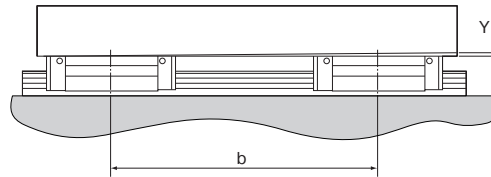

Standard Length and Maximum Length of the LM Rail

The table below shows the standard lengths and the maximum lengths of model SRW variations. If the maximum length of the desired LM rail exceeds them, jointed rails will be used. For the G dimension when a special length is required, we recommend selecting the corresponding G value from the table. The longer the G dimension is, the less stable the G area may become after installation, thus causing an adverse impact to accuracy.

If desiring connected use of this model, be sure to specify the overall length in terms of total length when placing an order so that we can manufacture the LM rail without leaving a level difference in the joint.

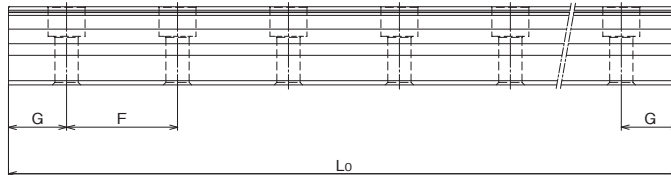

Standard Length and Maximum Length of the LM Rail for Model SRW

Unit:mm

	SRW 130LR	SRW 150LR
Standard length (L ₀)	1530	1340
	1890	1760
	2250	2180
	2610	2600
Standard pitch	90	105
G	45	40
Max length	3000	3000

Note 1: The maximum length varies with accuracy grades. Contact THK for details.

Note 2: If jointed rails are not allowed and a greater length than the maximum values above is required, contact THK.

Model SRW-LR

Dimensional Table for Model SRW-LR

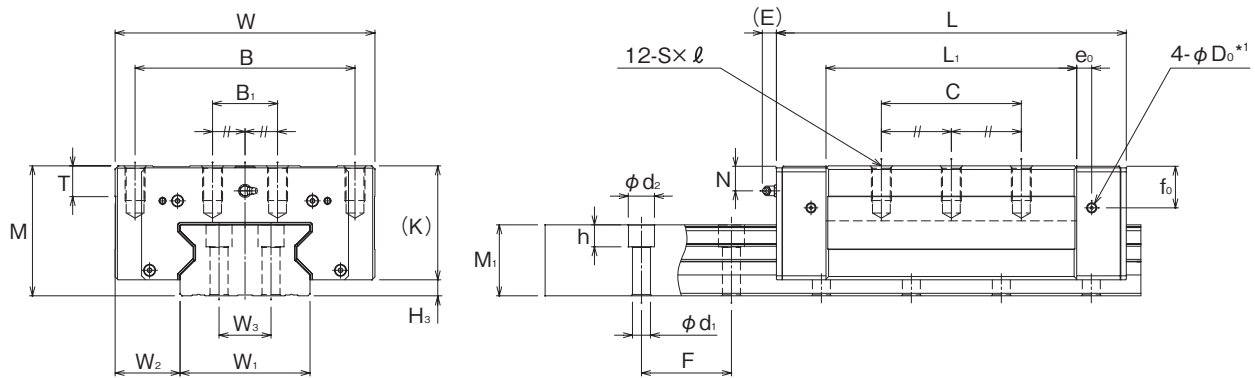

Unit:mm

Model No.	Outer dimensions			LM block dimensions													Grease Nipple	H ₃
	Height M	Width W	Length L	B	B ₁	C	S×ℓ	L ₁	T	K	N	E	e ₀	f ₀	D ₀			
SRW 130LR	130	260	350	220	65	140	M20×35	250.8	30	114	25	16	15	42	8.2	B-PT1/8	16	
SRW 150LR	150	300	395	260	75	200	M20×40	280.2	35	134	28.8	16	15	53	8.2	B-PT1/4	16	

Unit:mm

Model No.	LM rail dimensions						Basic load rating		Static permissible moment [kN-m] ^{*3}						Mass	
	Width W _{1-0.05}	W ₂	W ₃	Height M ₁	Pitch F	d ₁ ×d ₂ ×h	Maximum length ^{*2}	C [kN]	C ₀ [kN]	M _A 1 block	M _B Double casings	M _B 1 block	M _C Double casings	M _C 1 block	LM block [kg]	LM rail [kg/m]
SRW 130LR	130	65	52	71	90	18×26×22	3000	497	990	45.3	239	45.3	239	74.2	41.7	61.0
SRW 150LR	150	75	60	77	105	24×35×28	3000	601	1170	60	319	60	319	101.6	65.1	74.4

Note *1: The pilot hole for the side nipple is not drilled through in order to prevent foreign material from entering the LM block. THK will mount grease nipples per your request. Therefore, do not use the side nipple pilot holes for purposes other than mounting a grease nipple.

*2: The maximum length indicates the standard maximum length of an LM rail.

*3: Static permissible moment One block: static permissible moment value with one LM block

Double blocks : static permissible moment value with double block closely contacting with each other

Note: The removing/mounting jig is not included in the package as standard. If you desire to use it, contact THK.

Model Number Coding

SRW130 LR 2 KK C0 + 1530L P T - II

Model No. Type of LM block

No. of LM blocks used on the same rail

Radial clearance symbol (see P.3)

Dust prevention accessory symbol (See the General Catalog for details.)

LM rail length (in mm)

Accuracy symbol (see P.3)

Symbol for LM rail jointed use

Symbol for No. of rails used on the same plane (See the General Catalog for details.)

Note This model number indicates that a single-rail unit constitutes one set. (i.e., required number of sets when 2 rails are used in parallel is 2 at a minimum.) Those models equipped with QZ Lubricator cannot have a grease nipple.

Maximum Seal Resistance /Contamination protection accessory

Table 2 shows the maximum seal resistance value per LM block with the SRW...SS seal.

Model No.	Maximum Seal Resistance*
SRG 85LC	47
SRG100LC	53

* The maximum seal resistance value with lubricant applied.

Overall LM block length after a contamination protection accessory is attached.

Model No.	UU	SS	DD	ZZ	KK
SRW 130LR	350	350	361.2	365.2	376.4
SRW 150LR	395	395	406.2	411	422.2

Note 1: For details of contamination protection accessories, see the General Catalog.

Note 2: If you desire QZ or LaCS, contact THK.

Dedicated Bellows JSRG for Model SRW

The table below shows the dimensions of dedicated bellows JSRG for model SRW. Specify the corresponding model number of the desired bellows from the table.

Model No.	Main dimensions [mm]								
	W	H	H ₁	P	p	b ₁	t ₁	b ₂	t ₂
JSRW 130	220	96	96	36.5	35	165	35	60	55
JSRW 150	260	114	114	49	47	200	43.3	70	60

Model No.	Main dimensions [mm]				Extension rate A ($\frac{L_{max}}{L_{min}}$)	Supported model numbers
	Screw size S	Mounting bolt S ₁	a	b		
JSRW 130	M6	M6×8L	18	20	9	SRW 130LR
JSRW 150	M6	M6×8L	20	20	9	SRW 150LR

Model Number Coding

JSRW130 - 150 / 1350

Model No.

Dimensions of the bellows
(length when compressed /
length when extended)

Note: The length of the bellows is calculated as follow.

$$L_{min} = \frac{S}{(A-1)}$$

$L_{max} = L_{min} \cdot A$
S: Stroke length (mm)
A: Extension rate

Dedicated C-Cap for LM Rail Mounting Holes

If any of the LM rail mounting holes of an LM Guide is filled with cutting chips or foreign material, they may enter the LM block. Entrance of such foreign material can be prevented by covering each LM rail mounting hole with the dedicated cap to eliminate the level difference between all the hole tops and the top face of the LM rail.

Major dimensions of the C-Cap

Model No.	Model No.	Bolt used	Main dimensions [mm]	
			D	H
SRW 130	M16	M16	35.5	5.7
SRW 150	M22	M22	39.5	7.7

Greasing hole

Model SRW allows lubrication from both the side and top faces of the LM block. The greasing hole of standard types is not drilled through in order to prevent foreign matter from entering the LM block. When using the greasing hole, contact THK.

Mounting dimensions of the greasing holes

Model No.	Pilot hole for side nipple			Applicable nipple	Greasing hole on the top face		
	e ₀	f ₀	D ₀		D ₂ (O-ring)	V	e ₁
SRW 130	15	42	8.2	PT1/8	13 (P10)	0.4	10
SRW 150	15	53	8.2	PT1/4	13 (P10)	0.4	10

Dedicated Bellows JSRG for Model SRW

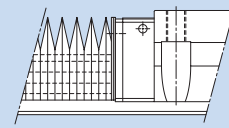
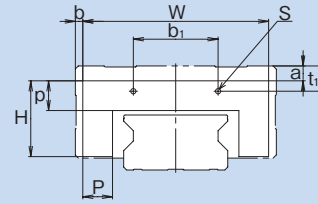

Note 1: For lubrication when using the dedicated bellows, contact THK.

Note 2: If you desire to use the dedicated bellows other than in horizontal mount (i.e., vertical, wall and inverted mount), or desire a heat-resistant type of bellows, contact THK.

Dedicated C-Cap for LM Rail Mounting Holes

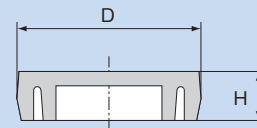

Greasing hole

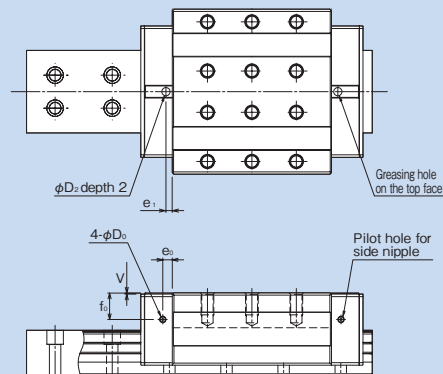

Precautions on Use

● Handling

- This product is a heavy object (over 20 kg). When carrying this heavy object, two or more people must hold it or a conveyor must be used. Failure to do so may cause injury or damage the product.
- Do not disassemble the parts. Doing so may let dust enter the product or lose some of the functions.
- Tilting an LM block or LM rail may cause them to fall by their own weight.
- Do not drop or hit the LM Guide. Doing so may cause injury or damage the product. If an impact is applied, some of the functions may be lost even if the product looks intact.
- If the mounting surface is machined with low accuracy, it may decrease the accuracy or the service life and damage the product.
- When mounting the LM block, secure it with bolts at 12 points to gain a sufficient rigidity.
- Take care to prevent foreign material such as dust and cutting chips from entering the product. Failure to do so may damage the roller circulating part or cause a functional loss.
- Some types of coolants may disrupt product functions. If using the product in an environment where the coolant may enter the LM block, contact THK in advance.
- Do not use the product at temperature of 80°C or higher. Contact THK if you desire to use the product at a temperature of 80°C or higher.
- If foreign material such as dust or cutting chips adheres to the product, replenish the lubricant after cleaning the product with pure white kerosene. For available types of detergent, contact THK.
- If using the LM Guide in an inverted orientation, take a measure such as adding a safety mechanism for preventing the LM Guide from falling. If the end plate is fractured in an accident or the like, rollers may drop off and the LM block may come off and fall from the LM rail.
- When using the product in locations exposed to constant vibrations or in special environments such as clean rooms, vacuum and low/high temperature, contact THK in advance.
- If you remove the LM block from the LM rail and then reassemble the LM block with the LM rail, be sure to use the removing/mounting jig and carefully remove and insert the LM block. The removing/mounting jig is not including in the package as standard. If you desire to use it, contact THK.
- If using the pilot holes (not drilled through to prevent foreign material from entering the product) for top and side nipples of the LM block, contact THK in advance.
- Nipples are mounted at THK. Do not use the pilot holes dedicated for the top and side nipples for purposes other than mounting the nipples. Doing so may damage the product.

● Lubrication

- Thoroughly remove anti-rust oil and feed lubricant before using the product. When planning to use a special lubricant, contact THK before using it.
- Do not mix lubricants of different physical properties.
- In locations exposed to constant vibrations or in special environments such as clean rooms, vacuum and low/high temperature, normal lubricants may not be used. Contact THK for details.
- When adopting oil lubrication, the lubricant may not be distributed throughout the LM system depending on the mounting orientation of the system. Contact THK for details.
- Lubrication interval varies according to the conditions. Contact THK for details.

● Storage

- When storing the LM Guide, enclose it in a package designated by THK and store it in a horizontal orientation while avoiding high temperature, low temperature and high humidity.

● “LM GUIDE” and “” are registered trademarks of THK CO., LTD.

- The photo may differ slightly in appearance from the actual product.
- The appearance and specifications of the product are subject to change without notice. Contact THK before placing an order.
- Although great care has been taken in the production of this catalog, THK will not take any responsibility for damage resulting from typographical errors or omissions.
- For the export of our products or technologies and for the sale for exports, THK in principle complies with the foreign exchange law and the Foreign Exchange and Foreign Trade Control Law as well as other relevant laws.

All rights reserved

THK CO., LTD.

HEAD OFFICE 3-1-6, NISHI-GOTANDA, SHINAGAWA-KU, TOKYO 141-8503 JAPAN
INTERNATIONAL SALES DEPARTMENT PHONE:+81-3-5434-0351 FAX:+81-3-5434-0353
Global site : <http://www.thk.com/>

NORTH AMERICA

THK America, Inc.

● HEADQUARTERS

Phone:+1-847-310-1111 Fax:+1-847-310-1271

● CHICAGO OFFICE

Phone:+1-847-310-1111 Fax:+1-847-310-1182

● NEW YORK OFFICE

Phone:+1-845-369-4035 Fax:+1-845-369-4909

● ATLANTA OFFICE

Phone:+1-770-840-7990 Fax:+1-770-840-7897

● LOS ANGELES OFFICE

Phone:+1-949-955-3145 Fax:+1-949-955-3149

● SAN FRANCISCO OFFICE

Phone:+1-925-455-8948 Fax:+1-925-455-8965

● BOSTON OFFICE

Phone:+1-781-575-1151 Fax:+1-781-575-9295

● DETROIT OFFICE

Phone:+1-248-858-9330 Fax:+1-248-858-9455

● TORONTO OFFICE

Phone:+1-905-820-7800 Fax:+1-905-820-7811

SOUTH AMERICA

THK Brasil LTDA

Phone:+55-11-3767-0100 Fax:+55-11-3767-0101

EUROPE

THK GmbH

● EUROPEAN HEADQUARTERS

Phone:+49-2102-7425-0 Fax:+49-2102-7425-217

● DÜSSELDORF OFFICE

Phone:+49-2102-7425-0 Fax:+49-2102-7425-299

● FRANKFURT OFFICE

Phone:+49-2102-7425-650 Fax:+49-2102-7425-699

● STUTTGART OFFICE

Phone:+49-7150-9199-0 Fax:+49-7150-9199-888

● MÜNCHEN OFFICE

Phone:+49-8937-0616-0 Fax:+49-8937-0616-26

● U.K. OFFICE

Phone:+44-1908-30-3050 Fax:+44-1908-30-3070

● ITALY MILANO OFFICE

Phone:+39-039-284-2079 Fax:+39-039-284-2527

● ITALY BOLOGNA OFFICE

Phone:+39-051-641-2211 Fax:+39-051-641-2230

● SWEDEN OFFICE

Phone:+46-8-445-7630 Fax:+46-8-445-7639

● AUSTRIA OFFICE

Phone:+43-7229-51400 Fax:+43-7229-51400-79

● SPAIN OFFICE

Phone:+34-93-652-5740 Fax:+34-93-652-5746

● TURKEY OFFICE

Phone:+90-216-362-4050 Fax:+90-216-362-4050

● PRAGUE OFFICE

Phone:+420-2-41025-100 Fax:+420-2-41025-199

THK France S.A.S.

Phone:+33-4-3749-1400 Fax:+33-4-3749-1401

CHINA

THK (CHINA) CO.,LTD.

● HEADQUARTERS

Phone:+86-411-8733-7111 Fax:+86-411-8733-7000

● SHANGHAI OFFICE

Phone:+86-21-6219-3000 Fax:+86-21-6219-9890

● BEIJING OFFICE

Phone:+86-10-8441-7277 Fax:+86-10-6590-3557

● CHENGDU OFFICE

Phone:+86-28-8526-8025 Fax:+86-28-8525-6357

● GUANGZHOU OFFICE

Phone:+86-20-8523-8418 Fax:+86-20-3801-0456

THK (SHANGHAI) CO.,LTD.

Phone:+86-21-6275-5280 Fax:+86-21-6219-9890

TAIWAN

THK TAIWAN CO.,LTD.

● TAIPEI HEAD OFFICE

Phone:+886-2-2888-3818 Fax:+886-2-2888-3819

● TAICHUNG OFFICE

Phone:+886-4-2359-1505 Fax:+886-4-2359-1506

● TAINAN OFFICE

Phone:+886-6-289-7668 Fax:+886-6-289-7669

KOREA

SEOUL REPRESENTATIVE OFFICE

Phone:+82-2-3468-4351 Fax:+82-2-3468-4353

SINGAPORE

THK LM SYSTEM Pte. Ltd.

Phone:+65-6884-5500 Fax:+65-6884-5550

INDIA

BANGALORE REPRESENTATIVE OFFICE

Phone:+91-80-2330-1524 Fax:+91-80-2314-8226

