



ADJUSTING NUTS AND THREADED RINGS





SUMMARY

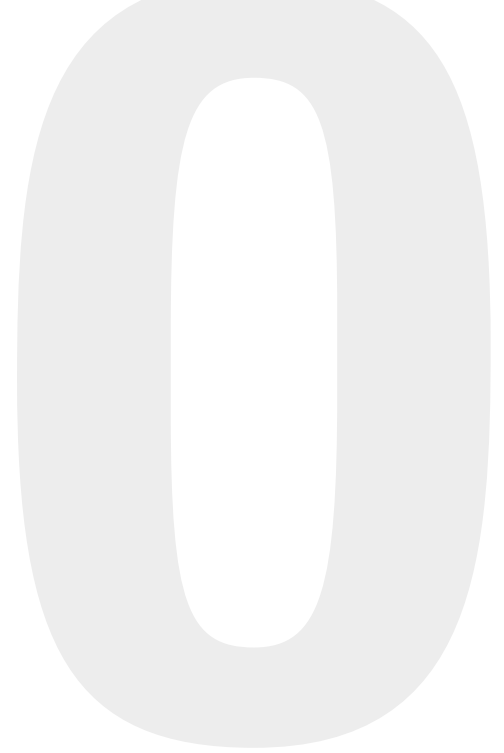

PAGE 4

1.0 NADELLA GROUP

PAGE 8

2.0 CLAMPING SYSTEM APPLICATIONS

PAGE 12

3.0 ADJUSTING NUTS AND THREADED RINGS

PAGE 20

4.0 SPECIAL APPLICATIONS

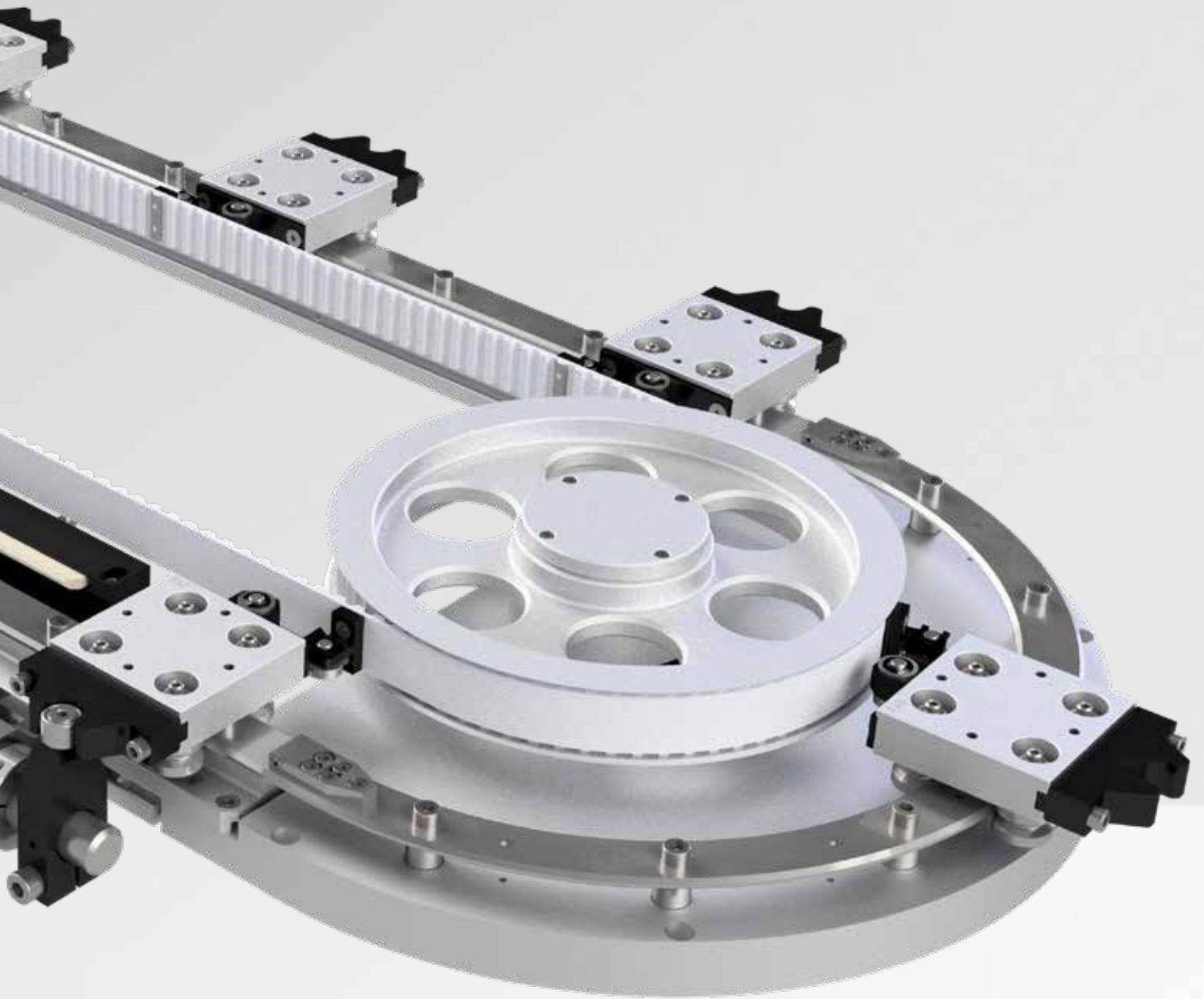

NADELLA GROUP



PAGE 06

1.1 THE GROUP

- Introduction
- Companies, brands and products overview
- Milestones
- Key numbers
- Application sectors

PAGE 07

1.2 THE NETWORK

- Introduction
- Worldwide network
- Branches and contacts
- Distributors coverage

THE SPECIALIST FOR MOTION TECHNOLOGY

Nadella Group is an expert system partner for all areas of motion technology, with specialized manufacturer companies and a worldwide sales network.

Wherever innovative ideas, customized solutions, precision and reliability are required, developers and design engineers rely on products and solutions from the Nadella Group.

COMPANIES, BRANDS AND PRODUCTS OVERVIEW



Linear Guide Systems



Linear Modules



Complete Systems



Bearings and Cam Followers



Adjusting Nuts & Rings

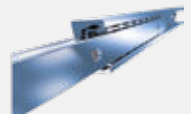

Telescopic Rails



Rod Ends and Spherical Plain Bearings



Clevises and Ball/Axial Joints



Precision Ball Screws



Rolled Ball Screws

MILESTONES

1930

NADELLA foundation in France

1958

Founding of NADELLA GMBH in Germany

1963

Founding of NADELLA S.P.A. in Italy

1984

Start of development and sale of Nadella Linear

2012

New Nadella subsidiaries in China and USA

2014

Acquisition of DURBAL

2018

Acquisition of CHIAVETTE UNIFICATE

2020

New Nadella subsidiaries in France and Spain
 Founding of Nadella Motion Technology Changxing Co. Ltd.
 Acquisition of SHUTON and IPIRANGA

KEY NUMBERS

1 Group

8 manufacturing plants

14 main locations
 Italy, Germany, France, United Kingdom, Spain, United States, China

leading the way in the international markets

in over **60** countries

for **90** years

APPLICATION SECTORS



RAILWAY TECHNOLOGY



WAREHOUSE & LOGISTICS



MEDICAL ENGINEERING

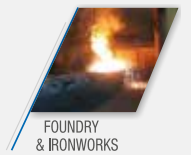

FOUNDRY & IRONWORKS

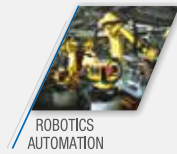

ROBOTICS AUTOMATION



PACKAGING INDUSTRY

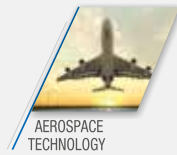

AEROSPACE TECHNOLOGY



PHARMACEUTICAL PRODUCTION



CUTTING & WELDING



HI-TECH PRODUCTION

THE SPECIALIST FOR MOTION TECHNOLOGY

Our customers' satisfaction is the basis for our success and growth. That is why we are at your service around the world and always keep your requirements as a priority.

We have a worldwide network of sales engineers and distributors in Europe, Asia and the USA. This allows us to ensure customer-oriented solutions and best in class delivery and service.

WORLDWIDE NETWORK

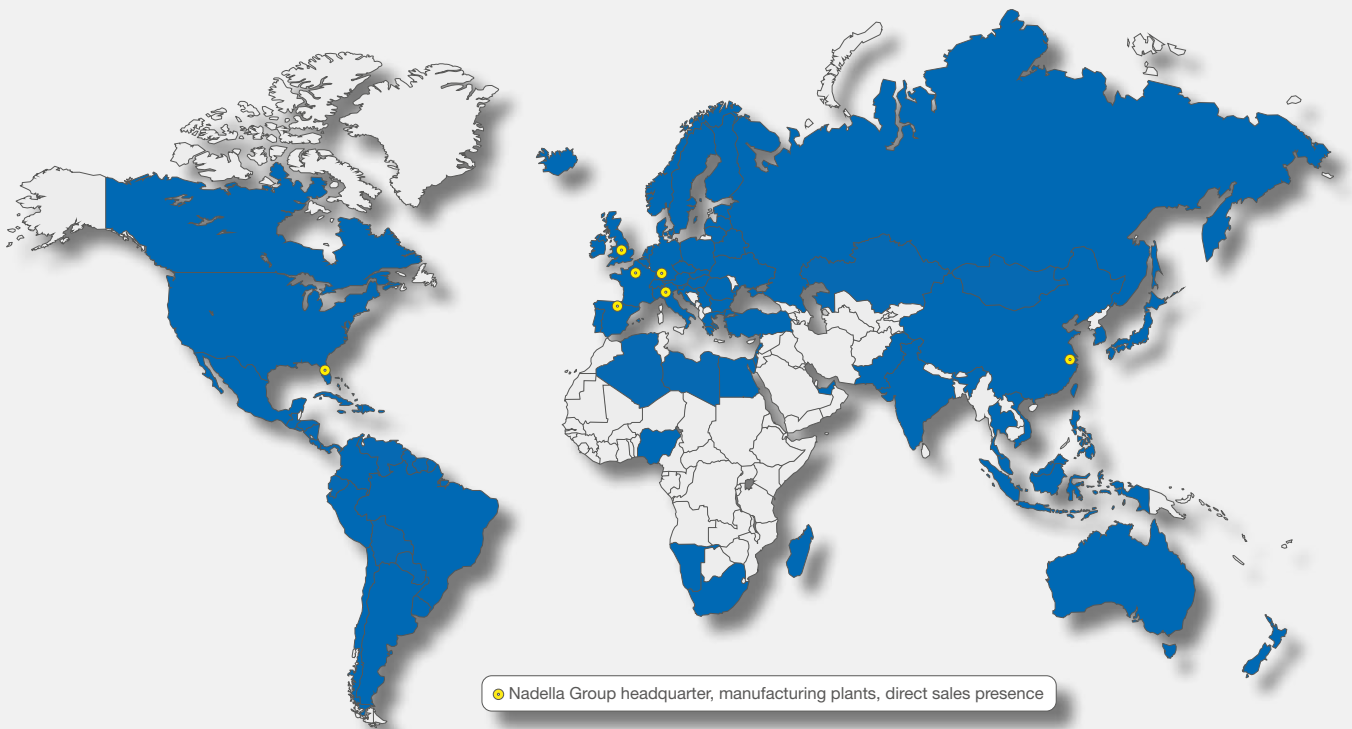

BRANCHES AND CONTACTS

NADELLA S.p.A. Italy

Via Melette, 16
20128 Milano
Tel.: +39 02 27 093
Fax: +39 02 257 64 79
customer.service@nadella.it
www.nadella.it

NADELLA S.A. Spain

Poligono Industrial Erratzu
Parcela G3. Pabellón 221 - Apdo.65
E-20130 Urnieta - Gipuzkoa
Tel. +34 943 336 370
ventas@nadella.es
www.nadella.com

NADELLA GmbH Germany

Rudolf-Diesel-Str. 28
71154 Nufringen
Tel.: +49 7032 9540-0
Fax: +49 7032 9540-25
info@nadella.de
www.nadella.de

DURBAL Metallwarenfabrik GmbH - Germany

Verrenberger Weg 2
74613 Öhringen
Tel.: +49 7941 9460-0
Fax: +49 7941 9460-90
info@durbal.de
www.durbal.de

NADELLA Inc. United States

14115 - 63 Way North
Clearwater - Florida 33760-3621
Tel.: +1 844-537-0330 (toll-free)
Fax: +1 844-537-0331
info@nadella.com
www.nadella.com

CHIAVETTE UNIFICATE S.p.A. Italy

Via G. Brodolini 6-8-10
40069 Zola Predosa, Bologna
Tel.: +39 051 75 87 67
Fax: +39 051 75 47 80
tescubal@chiavette.it
www.chiavette.com

NADELLA Linear Shanghai Co. Ltd. - China

Room D314, No. 245 Xinjunhuan
RoadMinhang, Shanghai 201114
Tel.: +86 21 5068 3835
Fax: +86 21 5038 7725
info@nadellalinear.com
www.nadella.cn.com

SHUTON S.A. Spain

Poligono Industrial Goian
C/Subilosa, 5 - 01170 LEGUTIANO
Tel.: +34 945 465 629
Fax: +34 945 465 610
shuton@shuton.com
www.shuton.com

NADELLA Sarl France

12 Parvis Colonel Arnaud Beltrame
Hall A 4ème étage
78000 Versailles
Tel.: +33 (0)1 7319 4048
service.client@nadella.fr
www.nadella.fr

HUSILLOS IPIRANGA Spain

Poligono Industrial Erratzu
Parcela G3. Pabellón 221 - Apdo.65
E-20130 Urnieta - Gipuzkoa
Tel. +34 943 336 370
info@ipirangahusillos.com
www.ipirangahusillos.com

DISTRIBUTORS COVERAGE

Austria	China	France	India	Korea	Portugal	Slovakia	Switzerland
Belgium	Czech Republic	Germany	Ireland	Netherlands	Romania	Slovenia	Taiwan
Brazil	Denmark	Great Britain	Israel	Norway	Russia	Spain	Turkey
Canada	Finland	Hungary	Italy	Poland	Singapore	Sweden	United States

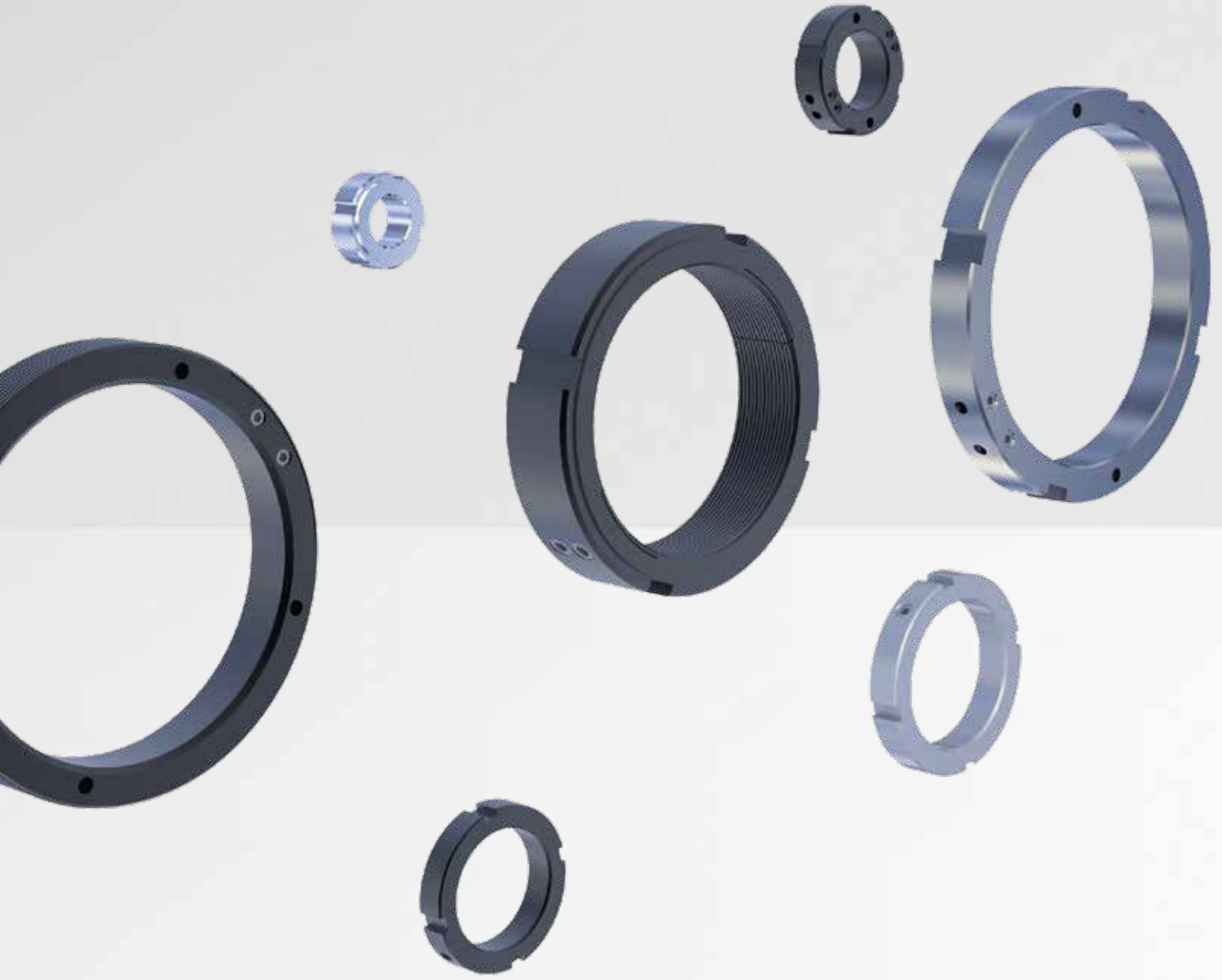

CLAMPING SYSTEM APPLICATIONS



PAGE 10

2.1 CLAMPING SYSTEM

PAGE 10

2.1 MOUNTING

PAGE 11

2.1 APPLICATIONS

CLAMPING SYSTEM APPLICATIONS

SPRING NUTS

The new generation of spring nuts consists of six different models, each of which uses the same clamping technology with a spring.

Clamping	Radial	Axial
Standard	LR	LF
Balanced	LRE	LFE
Heavy-duty	LRP	

Spring ring

Clamping	Axial
Standard	LX

CLAMPING SYSTEM

- The threaded bore of the nuts and outside threading of the rings is partially wired EDM to form a clamping spring. When tightening the Hc grub screws clamping is applied with a very strong pressure onto the threaded spring which meshes perfectly into the corresponding threads of the shaft or spindle.
- The contacted threaded surface of the spring pressing onto the threaded surface of the shaft/spindle, amplifies the clamping power, ensuring thereby a highly efficient clamping and making any unlocking hazard or loss of grip almost impossible.

REMARKS ABOUT UNLOCKING TORQUES

- Numerous parameters influence the unlocking torque:
 - Precision of the screw-nut assembly
 - Clamping strength applied to the Hc grub screws (applying pressure onto the threaded spring)
 - Nature of materials and corresponding surface quality various heat treatments and coatings
 - Environment (temperature, vibrations, atmospheric conditions, etc...)
 - Overall toughness of the assembly.
- The locking torque and axial loading values on this catalogue are given for static assemblies. They are indicative and do not involve the manufacturers responsibility.

MOUNTING THE NUTS AND RINGS

- The mounting occurs by driving the spring nuts and rings clockwise with standard spanner wrench (Din 1810) adapting onto the peripheral notches (b x h) of the nuts.
- The mounting can also easily be achieved thanks to the pin-key holes on the front-side of the nuts with the adequate key.
- Once in the correct position on the shaft/spindle the blocking can be simply secured by turning the Hc grub screws located either on the outside diameter or on the front side of the nuts.
- For nuts showing two locking springs or additional clamping screws (LRE - LFE - LRP) it is recommended to activate these screws alternatively and progressively so as to ensure an efficient locking.
- The use of a torque wrench is recommended so as to achieve a safe clamping of the Hc grub screw with the required value. However, using HEX male keys is also highly efficient.
- Very easy release of the nut through simple unlocking of the Hc grub screws.
- **ATTENTION : When disassembling, start with the clamping screw.**

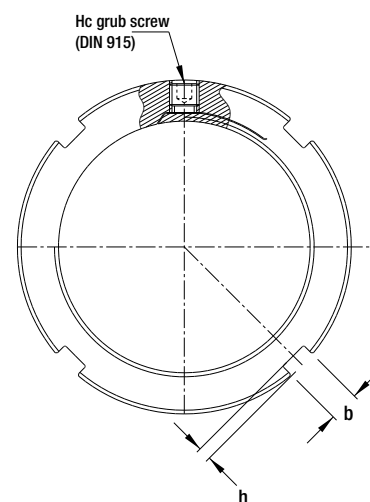

“HC Grub tool“ and “bxh“ example



LR Nut



LFE Nut



LX Ring

APPLICATIONS

The threaded spring nuts and rings are used whenever precision mechanisms require a precision clamping as well as a powerful and safe locking:

- Power transmission and motion technology
- Adjusting and clamping all types of bearings
- Mount/release of ball bearings
- Elimination of back lash
- Securing mechanical safety devices
- Templating spring-mounted measuring systems
- Safety nuts for use in high-temperature applications
- Periodical mounting and dismounting of adjusting locking/unlocking nuts and rings
- Assemblies subjected to vibrations
- Cyclic uneven rotation
- High and very high rotation spindle/shaft assemblies

ADVANTAGES OF THE NUTS

- A precise and powerful locking of bearings in axial positioning after assembly.
- A higher unlocking torque when compared to other locking techniques.
- Time-saving through a more simple technical design and construction of shaft-bodies and assemblies.
- No key slot required as for locking washers. Thus saving thread deburring operation.
- No use of locking washers, thus preventing seal damage.
- Clamping and locking the adjusting nut without any loss of axial precision.
- Easy mount and release re-usable many times without loss of precision.
- Recommended use under severe conditions (High-temperature, vibrations, etc...).

APPLICATIONS DETAILS

- Transmissions
- Machine-tool
- Textile machinery
- Printing industry
- Conditioning
- Special machinery
- Automotive industry
- Engine/turbine manufacturing
- Onshore and offshore industry
- Transportation
- Aeronauticals
- Marine equipment
- Nuclear industry
- Agriculture and Food industry
- Civil and military engineering
- Precision optical attachments



ADJUSTING NUTS AND THREADED RINGS



PAGE 14

3.1 ADJUSTING NUT LR

- Strong radial clamping
- High breakaway moment

PAGE 15

3.2 ADJUSTING NUT LRE

- Strong radial clamping
- High breakaway moment

PAGE 16

3.3 ADJUSTING NUT LF

- Effective thread locking by axial clamping screws on the resilient threaded surface
- High breakaway moment

PAGE 17

3.4 ADJUSTING NUT LFE

- Effective thread locking by axial clamping screws on the resilient threaded surface
- High breakaway moment

PAGE 18

3.5 ADJUSTING NUT LRP

- High radial protection via the internal thread
- Especially suitable for ball screw spindles

PAGE 19

3.6 ADJUSTING NUT LX

- Clamping spring external front locking LX
- Ideal for setting and tensioning rolling bearings

LR NUT

3.1

CHARACTERISTICS

- LR nuts are used wherever a strong radial clamping is required.
- The radial strength activated by turning the Hc grub screw is applied onto the threaded spring.
- The contact surface perpendicular to the threaded side allows the adjusting and locking of all types of bearings as well as other mechanical elements requiring very precise tolerances.

SPECIFICATIONS

- Material:
High elastic limit steel
- Peripheral notches:
4 x 90°
-  To ensure squareness and minimum run-out of the nuts and rings, all threading and contact face machining operations are performed in one setting.
- Grub screw:
Hc type with dog-point tip 14.9
- Standard manufacturing:
 - 4H class precision threading
 - right-hand thread
 - Fine-ground contact face
 - Marquing on the opposite side
 - Black oxide

OPTIONS

- Other versions are also available upon request:
 - Fine-ground threads
 - Left-hand thread
 - 2 twinned screws for increased locking torque
 - Other sizes
 - Other materials

*Values obtained with Hc grub screws:

M 6 screw - clamping torque	8 Nm
M 8 screw - clamping torque	18 Nm
M 10 screw - clamping torque	36 Nm

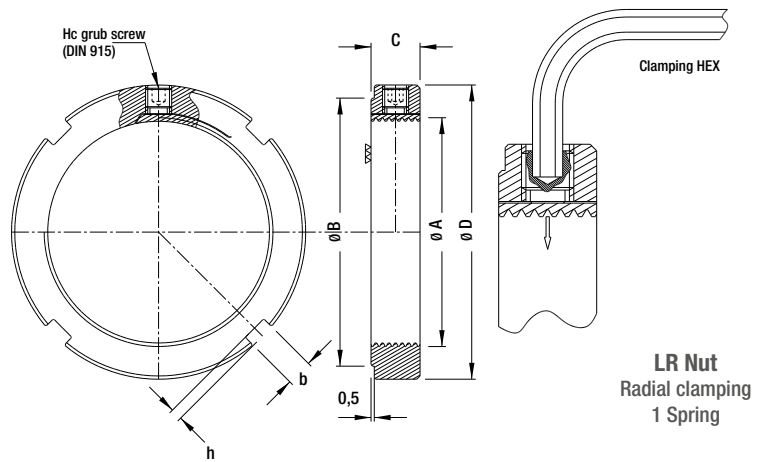

Type	Thread A	Ø D	Ø B	C	b x h	Hc grub screw	Unlocking Torque Nm*	Max Axial load N	Weight kg
LR 1	12 x 1,00	24	19	12	4 x 2	1 x M6	23	28 500	0,03
LR 2	14 x 1,00	26	21	12	4 x 2	1 x M6	26	33 500	0,04
LR 3	15 x 1,00	30	25	12	4 x 2	1 x M6	29	40 500	0,05
LR 4	17 x 1,00	32	27	12	4 x 2	1 x M6	32	46 100	0,06
LR 5	18 x 1,00	32	27	12	4 x 2	1 x M6	37	49 000	0,06
LR 6	20 x 1,00	35	30	12	4 x 2	1 x M6	42	54 600	0,06
LR 7	22 x 1,50	35	30	12	4 x 2	1 x M6	47	56 600	0,06
LR 8	25 x 1,50	40	35	12	5 x 2	1 x M6	53	67 100	0,07
LR 9	30 x 1,50	45	40	12	5 x 2	1 x M6	59	81 100	0,09
LR 10	32 x 1,50	46	41	12	5 x 2	1 x M6	65	92 900	0,09
LR 11	35 x 1,50	50	45	12	5 x 2	1 x M6	75	98 000	0,10
LR 12	38 x 1,50	52	47	12	5 x 2	1 x M6	83	101 900	0,10
LR 13	40 x 1,50	55	49	12	6 x 2,5	1 x M6	94	104 000	0,10
LR 14	42 x 1,50	56	50	12	6 x 2,5	1 x M6	105	109 300	0,11
LR 15	45 x 1,50	60	54	12	6 x 2,5	1 x M6	118	119 200	0,12
LR 16	50 x 1,50	65	59	12	6 x 2,5	1 x M6	132	134 900	0,13
LR 17	52 x 1,50	67	61	12	6 x 2,5	1 x M6	147	140 400	0,13
LR 18	55 x 2,00	75	68	15	7 x 3	1 x M8	512	168 900	0,23
LR 19	60 x 2,00	80	73	15	7 x 3	1 x M8	532	184 600	0,25
LR 20	65 x 2,00	85	78	15	7 x 3	1 x M8	560	203 500	0,27
LR 21	70 x 2,00	90	82	15	8 x 3,5	1 x M8	587	219 500	0,28
LR 22	75 x 2,00	95	87	15	8 x 3,5	1 x M8	615	237 000	0,3
LR 23	80 x 2,00	105	97	15	8 x 3,5	1 x M8	650	255 400	0,42
LR 24	85 x 2,00	110	102	15	8 x 3,5	1 x M8	675	273 300	0,44
LR 25	90 x 2,00	115	106	15	10 x 4	1 x M8	713	292 300	0,46
LR 26	95 x 2,00	120	111	15	10 x 4	1 x M8	750	308 800	0,49
LR 27	100 x 2,00	125	116	15	10 x 4	1 x M8	790	325 300	0,51
LR 28	105 x 2,00	130	119	15	12 x 5	1 x M8	830	341 700	0,52
LR 29	110 x 2,00	135	124	15	12 x 5	1 x M8	870	358 200	0,55
LR 30	115 x 2,00	140	129	15	12 x 5	1 x M8	930	377 000	0,57
LR 31	120 x 2,00	145	134	15	12 x 5	1 x M8	960	394 000	0,59
LR 32	125 x 2,00	150	139	15	12 x 5	1 x M8	1040	413 800	0,62
LR 33	130 x 2,00	155	144	15	12 x 5	1 x M8	> 2000	434 400	0,65
LR 34	135 x 2,00	165	152	20	14 x 6	1 x M10	> 2000	677 000	1,10
LR 35	140 x 2,00	170	157	20	14 x 6	1 x M10	> 2000	704 400	1,13
LR 36	145 x 2,00	175	162	20	14 x 6	1 x M10	> 2000	729 800	1,15
LR 37	150 x 2,00	180	167	20	14 x 6	1 x M10	> 2000	757 400	1,20

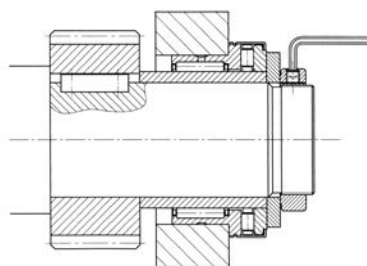

Img.1: Set up of a combination needle-bearing onto a drill press spindle.

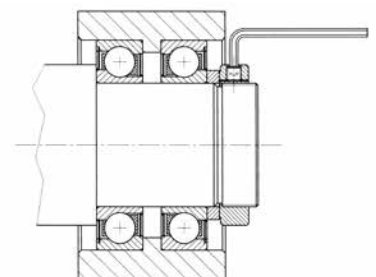

Img. 2: Set up the preloading of angular contact bearings.

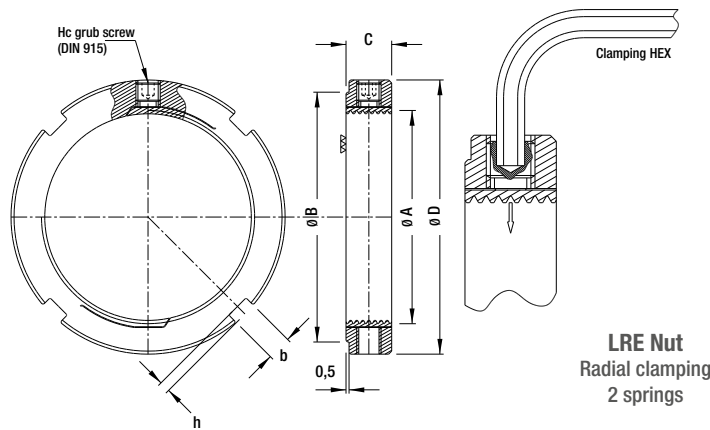

Type	Thread A	Ø D	Ø B	C	b x h	Hc grub screw	Unlocking Torque	Max Axial load	Weight
							Nm*	N	kg
LRE 7	22 x 1,50	35	30	12	4 x 2	2 x M6	94	37 800	0,06
LRE 8	25 x 1,50	40	35	12	5 x 2	2 x M6	106	48 000	0,07
LRE 9	30 x 1,50	45	40	12	5 x 2	2 x M6	118	58 000	0,09
LRE 10	32 x 1,50	46	41	12	5 x 2	2 x M6	130	74 400	0,09
LRE 11	35 x 1,50	50	45	12	5 x 2	2 x M6	150	77 700	0,10
LRE 12	38 x 1,50	52	47	12	5 x 2	2 x M6	166	82 000	0,10
LRE 13	40 x 1,50	55	49	12	6 x 2,5	2 x M6	188	85 200	0,10
LRE 14	42 x 1,50	56	50	12	6 x 2,5	2 x M6	210	89 600	0,11
LRE 15	45 x 1,50	60	54	12	6 x 2,5	2 x M6	236	100 000	0,12
LRE 16	50 x 1,50	65	59	12	6 x 2,5	2 x M6	264	115 600	0,13
LRE 17	52 x 1,50	67	61	12	6 x 2,5	2 x M6	294	120 400	0,13
LRE 18	55 x 2,00	75	68	15	7 x 3	2 x M8	1024	144 800	0,23
LRE 19	60 x 2,00	80	73	15	7 x 3	2 x M8	1064	158 300	0,25
LRE 20	65 x 2,00	85	78	15	7 x 3	2 x M8	1120	178 100	0,27
LRE 21	70 x 2,00	90	82	15	8 x 3,5	2 x M8	1174	192 100	0,28
LRE 22	75 x 2,00	95	87	15	8 x 3,5	2 x M8	1230	209 000	0,30
LRE 23	80 x 2,00	105	97	15	8 x 3,5	2 x M8	1300	228 000	0,42
LRE 24	85 x 2,00	110	102	15	8 x 3,5	2 x M8	1350	245 800	0,44
LRE 25	90 x 2,00	115	106	15	10 x 4	2 x M8	1426	265 800	0,46
LRE 26	95 x 2,00	120	111	15	10 x 4	2 x M8	1500	280 800	0,49
LRE 27	100 x 2,00	125	116	15	10 x 4	2 x M8	1580	295 800	0,51
LRE 28	105 x 2,00	130	119	15	12 x 5	2 x M8	1660	310 800	0,52
LRE 29	110 x 2,00	135	124	15	12 x 5	2 x M8	1740	325 700	0,55
LRE 30	115 x 2,00	140	129	15	12 x 5	2 x M8	1860	345 200	0,57
LRE 31	120 x 2,00	145	134	15	12 x 5	2 x M8	1920	362 800	0,59
LRE 32	125 x 2,00	150	139	15	12 x 5	2 x M8	2080	383 000	0,62
LRE 33	130 x 2,00	155	144	15	12 x 5	2 x M8	> 4000	406 200	0,65
LRE 34	135 x 2,00	165	152	20	14 x 6	2 x M10	> 4000	633 000	1,10
LRE 35	140 x 2,00	170	157	20	14 x 6	2 x M10	> 4000	660 800	1,13
LRE 36	145 x 2,00	175	162	20	14 x 6	2 x M10	> 4000	684 600	1,15
LRE 37	150 x 2,00	180	167	20	14 x 6	2 x M10	> 4000	712 900	1,20

CHARACTERISTICS

- LRE nuts are used wherever a strong radial clamping is required.
- Featuring 2 symmetrically opposed clamping springs at 180°, these nuts have two advantages when compared to the LR nuts:
 - Improved balance allowing higher rotation speeds
 - Twice as much unlocking torque for the same size.
- The radial strength activated by turning the 2 Hc grub screws is exercised onto the threaded clamping spring.
- The contact surface perpendicular to the threaded side allows the adjusting and securing of all types of bearings as well as other mechanical elements requiring very precise tolerances.

SPECIFICATIONS

- Material: High elastic limit steel
- Peripheral notches: 4 x 90°
- 

To ensure squareness and minimum run-out of the nuts and rings, all threading and contact face machining operations are performed in one setting.
- Grub screw: Hc type with dog-point tip 14.9
- Standard manufacturing:
 - 4H class precision threading
 - Right-hand thread
 - Fine-ground contact face
 - Marquing on the opposite side
 - Black oxide

OPTIONS

- Other versions are also available upon request:
 - fine-ground threads
 - Left-hand thread
 - 2 twinned screws for increased unlocking torque
 - Other sizes
 - Other materials

*Values obtained with Hc grub screws:

M 6 screw - clamping torque:	8 Nm
M 8 screw - clamping torque:	18 Nm
M 10 screw - clamping torque:	36 Nm

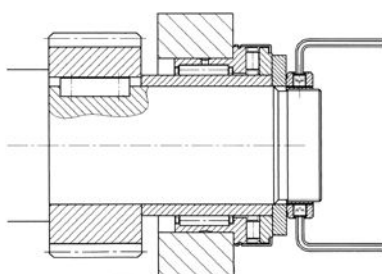

Img. 1: Adjusting of a combination needle-bearing onto a drill press spindle.

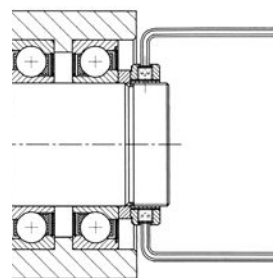

Img. 2: Example of application of one LRE Nut.

CHARACTERISTICS

- LF nuts are used wherever a strong radial clamping is not possible.
- The axial strength activated by turning the front Hc grub screw is applied onto the threaded clamping spring through 90° wedges.
- The resulting radial strength applies onto the clamping spring. The clamping pressure applied onto the threaded surface of the spring allows for a powerful locking.
- The contact surface perpendicular to the threaded side allows the adjusting and securing of all types of bearings as well as other mechanical elements requiring very precise tolerances.
- In addition to the notches, the holes located on the front side allow an easy positioning of the nut by mean of a spanner wrench.

SPECIFICATIONS

- Material:
High elastic limit steel
- Peripheral notches:
4 x 90°
-  To ensure squareness and minimum run-out of the nuts and rings, all threading and contact face machining operations are performed in one setting.
- Grub screw:
Hc type set-screw with cone tip 14.9
- Standard manufacturing:
 - 4H class precision threading
 - Right-hand thread
 - Fine-ground contact face
 - Marquing on the opposite side
 - Black oxide

OPTIONS

- Other versions are also available upon request:
 - Fine-ground threads
 - Left-hand thread
 - Other sizes
 - Other materials

*Values obtained with Hc grub screws:

M 4 screw - clamping torque:	2,5 Nm
M 5 screw - clamping torque:	5 Nm
M 6 screw - clamping torque:	8 Nm
M 8 screw - clamping torque:	18 Nm

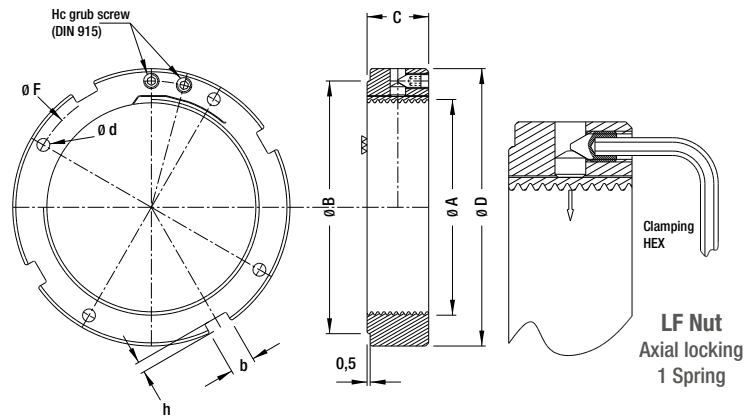

Type	Thread A	$\varnothing D$	$\varnothing B$	C	b x h	$\varnothing F$	$\varnothing d$	Hc grub screw	Unlocking Torque	Max Axial load	Weight
									Nm	N	kg
LF 1	12 x 1,00	28	22	15	4 x 2	20	3,2	1 x M4	4	36 200	0,05
LF 2	14 x 1,00	30	25	15	4 x 2	22	3,2	1 x M4	6	42 600	0,06
LF 3	15 x 1,00	31	26	15	4 x 2	23	3,2	1 x M4	6	51 500	0,06
LF 4	17 x 1,00	33	28	15	4 x 2	26	3,2	1 x M4	7	58 700	0,07
LF 5	18 x 1,00	34	29	15	4 x 2	26	3,2	2 x M4	9	55 400	0,07
LF 6	20 x 1,00	37	32	15	4 x 2	29	3,2	2 x M4	10	61 800	0,08
LF 7	22 x 1,50	39	34	15	4 x 2	30	3,2	2 x M4	12	64 700	0,09
LF 8	25 x 1,50	43	38	15	5 x 2	33	4,2	2 x M5	15	80 200	0,10
LF 9	30 x 1,50	48	43	15	5 x 2	39	4,2	2 x M5	20	100 600	0,12
LF 10	32 x 1,50	50	45	15	5 x 2	41	4,2	2 x M5	24	113 500	0,13
LF 11	35 x 1,50	53	48	15	5 x 2	44	4,2	2 x M5	29	118 500	0,14
LF 12	38 x 1,50	56	51	15	5 x 2	47	4,2	2 x M5	35	124 500	0,15
LF 13	40 x 1,50	58	52	15	6 x 2,5	50	4,2	2 x M5	41	127 100	0,15
LF 14	42 x 1,50	62	56	15	6 x 2,5	52	4,2	2 x M5	45	131 300	0,18
LF 15	45 x 1,50	65	59	15	6 x 2,5	55	4,2	2 x M5	55	143 400	0,19
LF 16	50 x 1,50	69	63	15	6 x 2,5	59	4,2	2 x M5	70	165 200	0,19
LF 17	52 x 1,50	72	66	15	6 x 2,5	62	4,2	2 x M5	85	171 900	0,22
LF 18	55 x 2,00	75	68	15	7 x 3	65	4,2	2 x M5	105	241 300	0,23
LF 19	60 x 2,00	80	73	20	7 x 3	72	4,2	2 x M5	130	263 800	0,33
LF 20	65 x 2,00	85	78	20	7 x 3	76	4,2	2 x M5	160	291 000	0,35
LF 21	70 x 2,00	90	82	20	8 x 3,5	81	4,2	2 x M5	200	313 900	0,36
LF 22	75 x 2,00	95	87	20	8 x 3,5	86	4,2	2 x M5	220	347 800	0,39
LF 23	80 x 2,00	105	97	20	8 x 3,5	93	5,2	2 x M6	240	371 300	0,55
LF 24	85 x 2,00	110	102	20	8 x 3,5	98	5,2	2 x M6	250	394 900	0,57
LF 25	90 x 2,00	115	106	20	10 x 4	104	5,2	2 x M6	265	422 500	0,60
LF 26	95 x 2,00	120	111	20	10 x 4	107	5,2	2 x M6	295	446 300	0,63
LF 27	100 x 2,00	125	116	20	10 x 4	114	5,2	2 x M6	325	470 200	0,65
LF 28	105 x 2,00	130	119	20	12 x 5	118	5,2	2 x M6	365	494 000	0,68
LF 29	110 x 2,00	135	124	20	12 x 5	122	5,2	2 x M6	405	517 800	0,72
LF 30	115 x 2,00	140	129	20	12 x 5	127	5,2	2 x M6	450	545 000	0,75
LF 31	120 x 2,00	145	134	20	12 x 5	132	5,2	2 x M6	500	574 300	0,78
LF 32	125 x 2,00	150	139	20	12 x 5	137	5,2	2 x M6	560	598 500	0,80
LF 33	130 x 2,00	155	144	20	12 x 5	142	5,2	2 x M6	635	626 600	0,85
LF 34	135 x 2,00	165	152	22	14 x 6	150	6,2	2 x M8	680	723 300	1,15
LF 35	140 x 2,00	170	157	22	14 x 6	155	6,2	2 x M8	1065	761 900	1,20
LF 36	145 x 2,00	175	162	22	14 x 6	160	6,2	2 x M8	1065	789 300	1,25
LF 37	150 x 2,00	180	167	22	14 x 6	165	6,2	2 x M8	1065	821 700	1,30

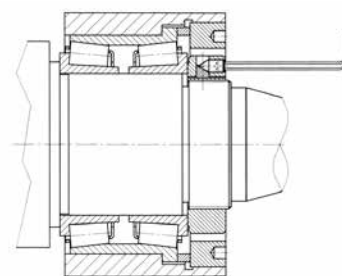

Set up of taper roller bearing onto a drill press spindle.

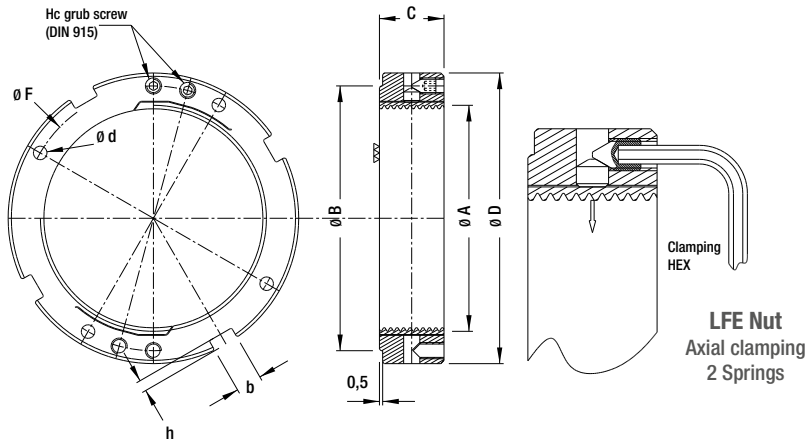

LFE Nut
Axial clamping
2 Springs

Type	Thread A	Ø D	Ø B	C	b x h	Ø F	Ø d	Hc grub screw	Unlocking Torque Nm*	Max Axial load N	Weight kg
LFE 7	22 x 1,50	39	34	15	4 x 2	30	3,2	4 x M4	24	37 800	0,09
LFE 8	25 x 1,50	43	38	15	5 x 2	33	4,2	4 x M5	30	49 400	0,10
LFE 9	30 x 1,50	48	43	15	5 x 2	39	4,2	4 x M5	40	67 100	0,12
LFE 10	32 x 1,50	50	45	15	5 x 2	41	4,2	4 x M5	48	83 600	0,13
LFE 11	35 x 1,50	53	48	15	5 x 2	44	4,2	4 x M5	58	87 400	0,14
LFE 12	38 x 1,50	56	51	15	5 x 2	47	4,2	4 x M5	70	91 700	0,15
LFE 13	40 x 1,50	58	52	15	6 x 2,5	50	4,2	4 x M5	82	96 500	0,15
LFE 14	42 x 1,50	62	56	15	6 x 2,5	52	4,2	4 x M5	90	96 800	0,18
LFE 15	45 x 1,50	65	59	15	6 x 2,5	55	4,2	4 x M5	110	108 800	0,19
LFE 16	50 x 1,50	69	63	15	6 x 2,5	59	4,2	4 x M5	140	132 200	0,19
LFE 17	52 x 1,50	72	66	15	6 x 2,5	62	4,2	4 x M5	170	137 600	0,22
LFE 18	55 x 2,00	75	68	15	7 x 3	65	4,2	4 x M5	210	193 000	0,23
LFE 19	60 x 2,00	80	73	20	7 x 3	72	4,2	4 x M5	260	211 000	0,33
LFE 20	65 x 2,00	85	78	20	7 x 3	76	4,2	4 x M5	320	238 600	0,35
LFE 21	70 x 2,00	90	82	20	8 x 3,5	81	4,2	4 x M5	400	257 300	0,36
LFE 22	75 x 2,00	95	87	20	8 x 3,5	86	4,2	4 x M5	440	298 100	0,39
LFE 23	80 x 2,00	105	97	20	8 x 3,5	93	5,2	4 x M6	480	318 300	0,55
LFE 24	85 x 2,00	110	102	20	8 x 3,5	98	5,2	4 x M6	500	338 600	0,57
LFE 25	90 x 2,00	115	107	20	10 x 4	104	5,2	4 x M6	530	366 700	0,60
LFE 26	95 x 2,00	120	111	20	10 x 4	107	5,2	4 x M6	590	387 400	0,63
LFE 27	100 x 2,00	125	117	20	10 x 4	114	5,2	4 x M6	650	408 100	0,65
LFE 28	105 x 2,00	130	119	20	12 x 5	118	5,2	4 x M6	730	428 800	0,68
LFE 29	110 x 2,00	135	124	20	12 x 5	122	5,2	4 x M6	810	449 500	0,72
LFE 30	115 x 2,00	140	129	20	12 x 5	127	5,2	4 x M6	900	476 900	0,75
LFE 31	120 x 2,00	145	134	20	12 x 5	132	5,2	4 x M6	1000	508 600	0,78
LFE 32	125 x 2,00	150	139	20	12 x 5	137	5,2	4 x M6	1120	530 000	0,80
LFE 33	130 x 2,00	155	144	20	12 x 5	142	5,2	4 x M6	1270	559 200	0,85
LFE 34	135 x 2,00	165	152	22	14 x 6	150	6,2	4 x M8	1359	645 400	1,15
LFE 35	140 x 2,00	170	157	22	14 x 6	155	6,2	4 x M8	2130	692 600	1,20
LFE 36	145 x 2,00	175	162	22	14 x 6	160	6,2	4 x M8	2130	717 600	1,25
LFE 37	150 x 2,00	180	167	22	14 x 6	165	6,2	4 x M8	2130	752 500	1,30

CHARACTERISTICS

- LFE nuts are used wherever radial clamping is not possible. They are therefore highly recommended for securing parts inside housings or deep chambers as well as for mounting bearings inside such places.
- Featuring 2 symmetrically opposed clamping springs at 180°, these nuts have two advantages when compared to LF nuts:
 - Increased balance allowing higher rotation speeds
 - Twice as much locking power for the same size
- The axial strength activated by turning the 2 Hc grub screws is exercised onto the threaded spring through 90° wedges.
- The resulting radial strength applies onto the threaded spring. The clamping pressure applied onto the threaded surface of the spring allows for a powerful locking.
- The contact surface perpendicular to the threaded side allows the adjusting and clamping of all types of bearings as well as other mechanical elements requiring very precise tolerances.
- In addition to the notches, the holes located on the front side allow an easy positioning of the nut by mean of a spanner wrench.

SPECIFICATIONS

- Material: High elastic limit steel
- Peripheral notches: 4 x 90°
-  To ensure squareness and minimum run-out of the nuts and rings, all threading and contact face machining operations are performed in one setting.
- Grub screw: Hc type with dog-point tip 14.9
- Standard manufacturing:
 - 4H class precision threading
 - Right-hand thread
 - Fine-ground contact face
 - Marquing on the opposite side
 - Black oxide

OPTIONS

- Other versions are also available upon request:
 - Fine-ground threads
 - Left-hand thread
 - Other sizes
 - Other materials

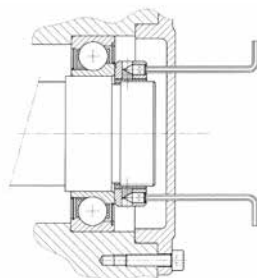

Backlash-free adjustment of an angular contact ball bearing.

LRP NUT

CHARACTERISTICS

- LRP nuts are used wherever heavy duty clamping for ball bearings is required.
- Larger nuts, symmetrical clamping springs and bigger screws ensure an increased unlocking torque as well as a much stronger resistance to axial load stress.
- The contact surface perpendicular to the threaded side allows the adjusting and securing of all types of bearings as well as other mechanical elements requiring very precise tolerances.

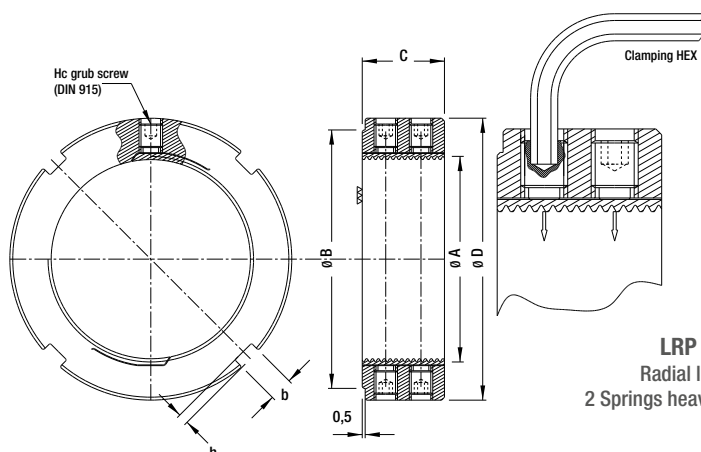

SPECIFICATIONS

- Material:
High elastic limit steel
- Peripheral notches:
4 x 90°
- 
To ensure squareness and minimum run-out of the nuts and rings, all threading and contact face machining operations are performed in one setting.
- Grub screw:
Hc type with dog-point tip 14.9
- Standard manufacturing:
 - 4H class precision threading
 - Right-hand thread
 - Fine-ground contact face
 - Marquing on the opposite side
 - Black oxide

OPTIONS

- Other versions are also available upon request:
 - Fine-ground threads
 - Left-hand thread
 - Other sizes
 - Other materials

Type	Thread A	Ø D	Ø B	C	b x h	Hc grub screw	Max Axial load N
LRP 20.150	20 x 1,50	42	37	16	5 x 2	2 x M8	48 861
LRP 22.150	22 x 1,50	44	39	16	5 x 2	2 x M8	56 997
LRP 25.150	25 x 1,50	47	42	16	5 x 2	2 x M8	68 558
LRP 30.150	30 x 1,50	52	47	16	5 x 2	2 x M8	91 109
LRP 32.150	32 x 1,50	55	50	16	5 x 2	2 x M8	101 813
LRP 35.150	35 x 1,50	60	55	16	5 x 2	2 x M8	116 513
LRP 38.150	38 x 1,50	62	57	16	5 x 2	2 x M8	126 786
LRP 40.150	40 x 1,50	65	59	16	6 x 2,5	2 x M8	139 203
LRP 42.150	42 x 1,50	68	62	16	6 x 2,5	2 x M8	146 337
LRP 45.150	45 x 1,50	70	64	16	6 x 2,5	2 x M8	163 319
LRP 50.150	50 x 1,50	72	66	28	6 x 2,5	4 x M8	290 849
LRP 55.150	55 x 1,50	78	71	28	7 x 3	4 x M8	327 796
LRP 55.200	55 x 2,00	78	71	28	7 x 3	4 x M8	297 488
LRP 60.150	60 x 1,50	83	76	28	7 x 3	4 x M8	358 134
LRP 60.200	60 x 2,00	83	76	28	7 x 3	4 x M8	330 268
LRP 65.150	65 x 1,50	88	81	28	7 x 3	4 x M8	402 859
LRP 65.200	65 x 2,00	88	81	28	7 x 3	4 x M8	358 400
LRP 70.150	70 x 1,50	96	88	28	8 x 3,5	4 x M8	440 525
LRP 70.200	70 x 2,00	96	88	28	8 x 3,5	4 x M8	407 345
LRP 75.150	75 x 1,50	104	96	28	8 x 3,5	4 x M8	482 416
LRP 75.200	75 x 2,00	104	96	28	8 x 3,5	4 x M8	446 561
LRP 80.200	80 x 2,00	110	102	32	8 x 3,5	4 x M10	558 080
LRP 85.200	85 x 2,00	115	107	32	8 x 3,5	4 x M10	606 075
LRP 90.150	90 x 1,50	120	111	32	10 x 4	4 x M10	666 863
LRP 90.200	90 x 2,00	120	111	32	10 x 4	4 x M10	651 140
LRP 95.200	95 x 2,00	125	116	32	10 x 4	4 x M10	687 844
LRP 100.200	100 x 2,00	130	121	32	10 x 4	4 x M10	734 407
LRP 105.200	105 x 2,00	135	124	32	12 x 5	4 x M10	776 789
LRP 110.200	110 x 2,00	138	127	32	12 x 5	4 x M10	825 099
LRP 115.200	115 x 2,00	145	134	32	12 x 5	4 x M10	868 730
LRP 120.200	120 x 2,00	148	137	32	12 x 5	4 x M10	912 861
LRP 125.200	125 x 2,00	155	144	32	12 x 5	4 x M10	957 491
LRP 130.200	130 x 2,00	158	147	32	12 x 5	4 x M10	1 002 620
LRP 135.200	135 x 2,00	165	152	32	14 x 6	4 x M10	1 048 248
LRP 140.200	140 x 2,00	168	155	32	14 x 6	4 x M10	1 087 450
LRP 145.200	145 x 2,00	175	162	32	14 x 6	4 x M10	1 133 828
LRP 150.200	150 x 2,00	178	165	32	14 x 6	4 x M10	1 180 705
LRP 155.300	155 x 3,00	185	172	32	14 x 6	4 x M10	1 184 672
LRP 160.300	160 x 3,00	188	175	32	14 x 6	4 x M10	1 231 267
LRP 165.300	165 x 3,00	195	182	32	14 x 6	4 x M10	1 278 361
LRP 170.300	170 x 3,00	198	185	32	14 x 6	4 x M10	1 325 955
LRP 180.300	180 x 3,00	210	197	32	14 x 6	4 x M10	1 413 749
LRP 190.300	190 x 3,00	220	207	32	14 x 6	4 x M10	1 493 151
LRP 200.300	200 x 3,00	230	217	32	14 x 6	4 x M10	1 582 443

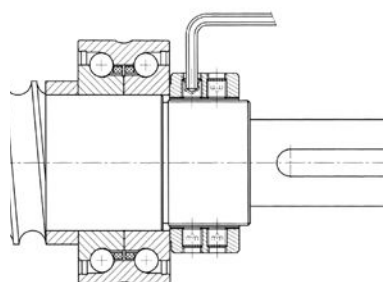

LRP nuts for mounting and set up of a ball screw.

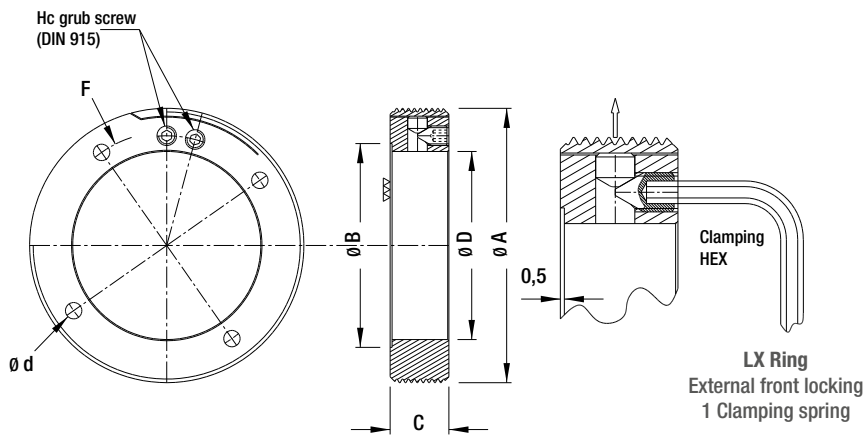

Type	Thread A	Ø D	Ø B	C	Ø d	Hc grub screw	Max Axial load	Weight
		mm	mm	mm	mm		N	kg
LX 28	28 x 1,50	12	16	15	3,2	1 x M4	97 200	0,05
LX 30	30 x 1,50	14	20	15	3,2	1 x M4	104 400	0,06
LX 32	32 x 1,50	15	20	15	3,2	1 x M4	119 500	0,06
LX 34	34 x 1,50	18	22	15	3,2	1 x M4	127 200	0,06
LX 37	37 x 1,50	20	26	15	3,2	1 x M4	138 800	0,06
LX 39	39 x 1,50	22	28	15	3,2	1 x M4	146 500	0,08
LX 40	40 x 1,50	23	29	15	3,2	1 x M4	152 800	0,08
LX 42	42 x 1,50	24	31	15	3,2	2 x M4	160 700	0,09
LX 44	44 x 1,50	26	32	15	3,2	2 x M4	168 500	0,09
LX 46	46 x 1,50	28	33	15	3,2	2 x M4	179 200	0,11
LX 47	47 x 1,50	29	34	15	3,2	2 x M4	183 200	0,11
LX 49	49 x 1,50	31	34	15	3,2	2 x M4	188 100	0,10
LX 50	50 x 1,50	32	35	15	3,2	2 x M4	173 500	0,11
LX 54	54 x 1,50	36	40	15	3,2	2 x M4	187 700	0,15
LX 57	57 x 1,50	39	44	15	3,2	2 x M4	198 300	0,14
LX 60	60 x 1,50	42	50	15	3,2	2 x M4	208 900	0,14
LX 63	63 x 1,50	43	46	15	4,2	2 x M5	219 500	0,17
LX 64	64 x 1,50	44	46	15	4,2	2 x M5	223 000	0,18
LX 67	67 x 1,50	47	47	15	4,2	2 x M5	237 400	0,19
LX 70	70 x 1,50	48	48	15	4,2	2 x M5	248 200	0,21
LX 74	74 x 1,50	54	57	15	4,2	2 x M5	262 600	0,21
LX 77	77 x 1,50	55	64	15	4,2	2 x M5	275 000	0,33
LX 80	80 x 1,50	55	55	20	4,2	2 x M5	384 800	0,37
LX 82	82 x 1,50	62	68	20	4,2	2 x M5	394 500	0,33
LX 87	87 x 1,50	67	76	20	4,2	2 x M5	421 400	0,34
LX 92	92 x 1,50	72	80	20	4,2	2 x M5	450 000	0,35
LX 97	97 x 1,50	77	85	20	4,2	2 x M5	474 700	0,37
LX 100	100 x 2,00	80	90	20	4,2	2 x M5	488 000	0,40
LX 102	102 x 2,00	82	91	20	4,2	2 x M5	497 900	0,42
LX 107	107 x 2,00	82	92	20	5,2	2 x M6	522 600	0,53
LX 112	112 x 2,00	87	100	20	5,2	2 x M6	547 300	0,55
LX 117	117 x 2,00	92	101	20	5,2	2 x M6	575 500	0,57
LX 122	122 x 2,00	97	107	20	5,2	2 x M6	602 200	0,60
LX 125	125 x 2,00	100	110	20	5,2	2 x M6	620 800	0,62
LX 127	127 x 2,00	102	110	20	5,2	2 x M6	630 900	0,63
LX 132	132 x 2,00	107	116	20	5,2	2 x M6	661 800	0,66
LX 142	142 x 2,00	117	118	20	5,2	2 x M6	714 600	0,73
LX 147	147 x 2,00	122	133	20	5,2	2 x M6	740 000	0,74
LX 152	152 x 2,00	127	138	20	5,2	2 x M6	767 600	0,78
LX 160	160 x 2,00	135	145	20	5,2	2 x M6	808 400	0,83

CHARACTERISTICS

- LX rings feature the same principles as those of the LF nuts, applying the same to the bores and being consequently perfectly adapted for securing parts inside housings or chambers.
- The axial strength activated by turning the Hc grub screw is activated onto the threaded spring through 90° wedges.
- The resulting radial strength applies onto the threaded spring.
- The clamping pressure applied onto the threaded surface of the spring allows for a powerful locking.
- The contact surface perpendicular to the threaded side allows the adjusting and locking of all types of bearings as well as other mechanical elements requiring very precise tolerances.
- In addition to the notches, the holes located on the front side allow an easy positioning of the ring by mean of a spanner wrench.

SPECIFICATIONS

- Material:** High elastic limit steel
- Peripheral notches:** 4 at 90°
-  To ensure squareness and minimum run-out of the nuts and rings, all threading and contact face machining operations are performed in one setting.
- Screw:** Hc type set-screw with cone tip 14.9
- Standard manufacturing:**
 - 4g class precision threading
 - Fine ground threads
 - Right-hand thread
 - Fine-ground contact face
 - Marquing on the opposite side
 - Black oxide

OPTIONS

- Other versions are also available upon request:
 - Left-hand thread
 - Additional clamping springs
 - Other sizes
 - Other materials

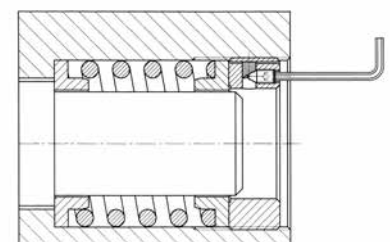

Pre-loading or relief setting of a spring mounted device inside a housing.



SPECIAL APPLICATIONS



PAGE 22

4.1 SPECIAL GEOMETRIES

PAGE 22

4.2 TIGHTENING TABS OR ADDITIONAL EXTERNAL NOTCHES

PAGE 23

4.3 ALTERNATIVE MATERIALS AND COATINGS

PAGE 23

4.4 DIMENSIONS AND THREAD PITCH ON REQUEST

SPECIAL APPLICATIONS EXAMPLES

SPECIAL GEOMETRIES

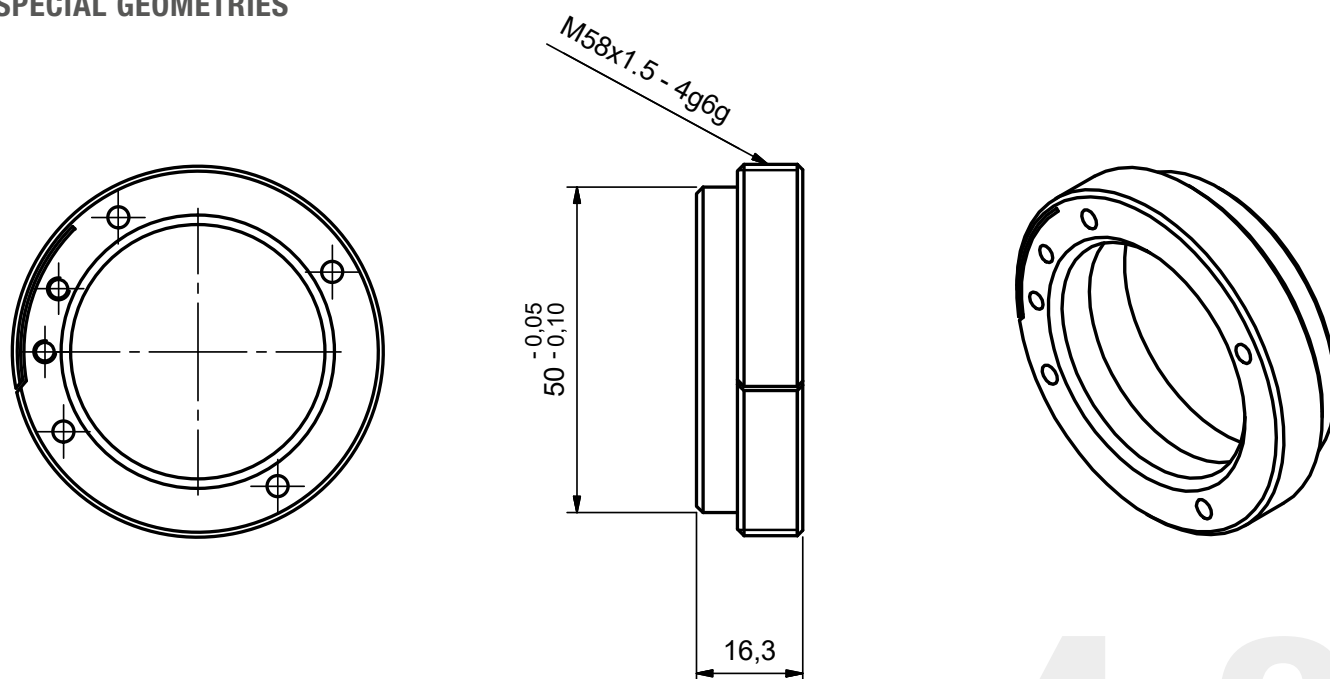

TIGHTENING TABS OR ADDITIONAL EXTERNAL NOTCHES

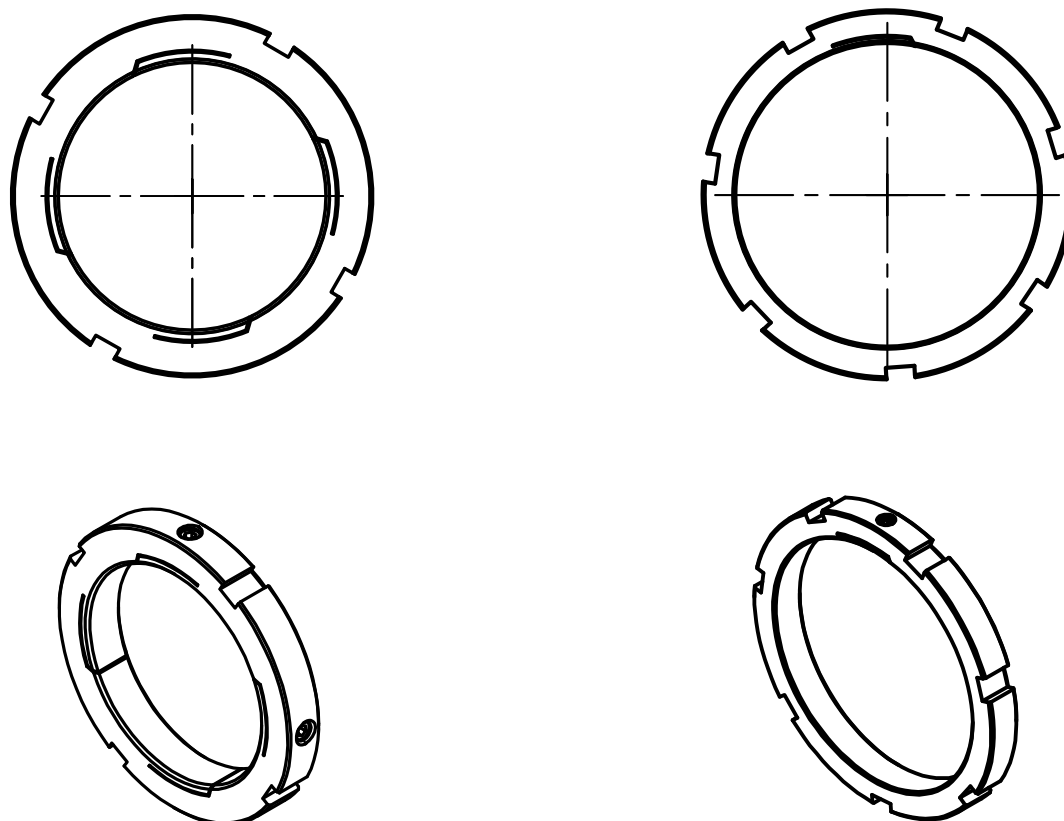

4.3

ALTERNATIVE MATERIALS AND COATINGS

ALTERNATIVE MATERIALS

- Aluminum 5083 (AG4,5)
- Stainless steel (AISI316, AISI304)
- 42CD4

COATINGS

- Phosphating
- Galvanization

4.4

DIMENSIONS AND THREAD PITCH ON REQUEST

- LARGER DIAMETER (maximum diameter: 900 mm)

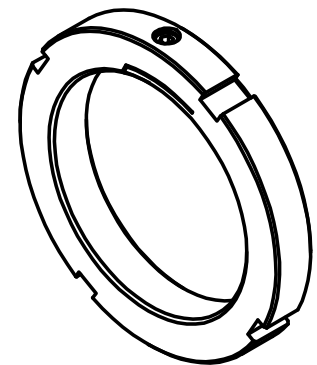
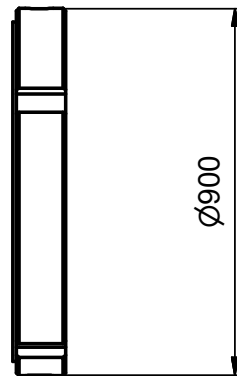
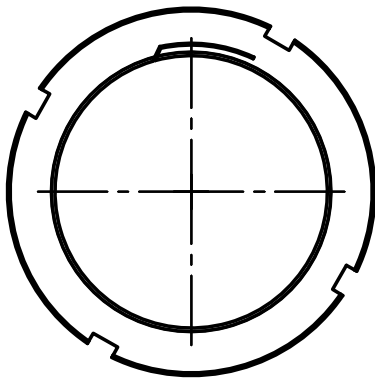

- REDUCED THICKNESS (example: special LF25)

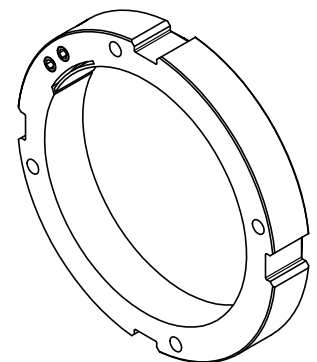
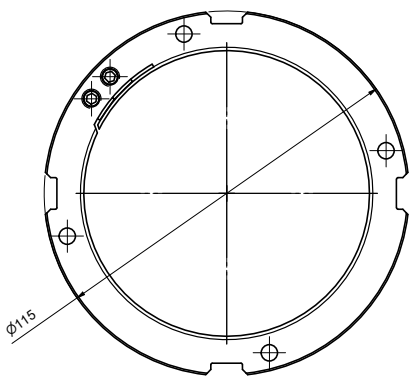

NOTES

A large grid of graph paper for taking notes, consisting of 20 columns and 30 rows of small squares.



NADELLA / nadella.com

DURBAL / durbal.com

CHIAVETTE UNIFICATE / chiavette.com

IPIRANGA / ipirangahusillos.com

SHUTON / shuton.com

THE SPECIALIST FOR MOTION TECHNOLOGY

SF211EN

Version 02/2021 · Nadella Group | nadella.com | Errors and omissions excepted.