

LINEAR GUIDE SYSTEMS





NADELLA

FKU65NX - PATENT

B 10

SUMMARY



PAGE 4	1.0 COMPANY	
PAGE 8	2.0 PRODUCT OVERVIEW	
PAGE 16	3.0 HEAVY-LINE	NX
	<ul style="list-style-type: none">• For high loads and difficult ambient conditions• Robust guide rollers with tapered roller bearings• Guide rail for fixed and floating bearings	
PAGE 36	4.0 ROLBLOC	NX
	<ul style="list-style-type: none">• For extremely high loads and robust applications• Up to 15 t per carriage• High compensation for a simple mounting	
PAGE 46	5.0 V-LINE	NX
	<ul style="list-style-type: none">• Full and half rail in steel with V profile• For all applications and loads• Very extensive design possibilities	
PAGE 70	6.0 MULTI-MOTION-LINE	NX
	<ul style="list-style-type: none">• Circular rails based on the profiles of V-Line• Circular rails, oval circuits and ring circuits	
PAGE 82	7.0 C-LINE	
	<ul style="list-style-type: none">• Guide rollers for fixed and floating bearing constructions• High speeds and acceleration• Maintenance-free due to integrated lubrication system	
PAGE 102	8.0 BASE-LINE	NX
	<ul style="list-style-type: none">• Starter type line for light and medium loads• Low and space-saving design	
PAGE 122	9.0 FLEXI-LINE 645	NX
	<ul style="list-style-type: none">• Dimensions according DIN to 645 with flexible configuration• For light and medium loads• Ready-to-install	
PAGE 128	10.0 U-LINE	NX
	<ul style="list-style-type: none">• For light and medium loads• Compact design of U-Line guides with inside carriage	
PAGE 146	11.0 TECHNICAL FEATURES	

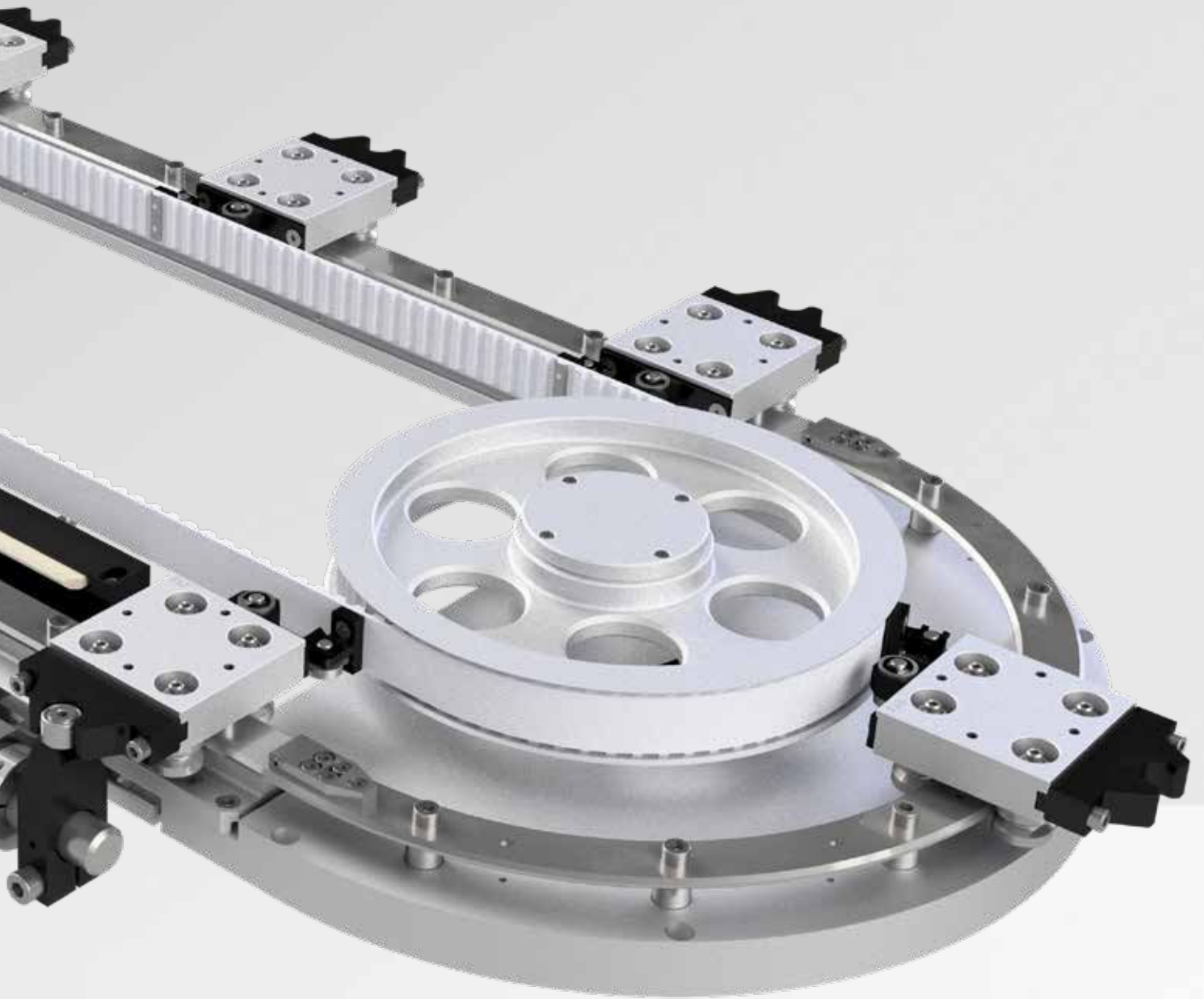

NADELLA GROUP



PAGE 06

1.1 THE GROUP

- Introduction
- Companies, brands and products overview
- Milestones
- Key numbers
- Application sectors

PAGE 07

1.2 THE NETWORK

- Introduction
- Worldwide network
- Branches and contacts
- Distributors coverage

THE SPECIALIST FOR MOTION TECHNOLOGY

Nadella Group is an expert system partner for all areas of motion technology, with specialized manufacturer companies and a worldwide sales network.

Wherever innovative ideas, customized solutions, precision and reliability are required, developers and design engineers rely on products and solutions from the Nadella Group.

COMPANIES, BRANDS AND PRODUCTS OVERVIEW



Linear Guide Systems



Linear Modules



Complete Systems



Bearings and Cam Followers



Adjusting Nuts & Rings

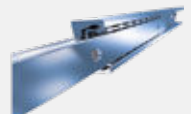

Telescopic Rails



Rod Ends and Spherical Plain Bearings



Clevises and Ball/Axial Joints



Precision Ball Screws



Rolled Ball Screws

MILESTONES

1930

NADELLA foundation in France

1958

Founding of NADELLA GMBH in Germany

1963

Founding of NADELLA S.P.A. in Italy

1984

Start of development and sale of Nadella Linear

2012

New Nadella subsidiaries in China and USA

2014

Acquisition of DURBAL

2018

Acquisition of CHIAVETTE UNIFICATE

2019

Founding of Nadella Motion Technology Changxing Co. Ltd.

2020

New Nadella subsidiaries in France and Spain
Acquisition of SHUTON and IPIRANGA

KEY NUMBERS

1 Group

7 manufacturing plants

13 main locations
Italy, Germany, France, United Kingdom, Spain, United States, China

leading the way in the international markets

in over **60** countries

for **90** years

APPLICATION SECTORS



RAILWAY TECHNOLOGY



WAREHOUSE & LOGISTICS



MEDICAL ENGINEERING



FOUNDRY & IRONWORKS



ROBOTICS AUTOMATION



PACKAGING INDUSTRY

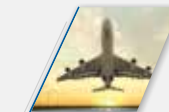

AEROSPACE TECHNOLOGY



PHARMACEUTICAL PRODUCTION



CUTTING & WELDING



HI-TECH PRODUCTION

THE SPECIALIST FOR MOTION TECHNOLOGY

Our customers' satisfaction is the basis for our success and growth. That is why we are at your service around the world and always keep your requirements as a priority.

We have a worldwide network of sales engineers and distributors in Europe, Asia and the USA. This allows us to ensure customer-oriented solutions and best in class delivery and service.

WORLDWIDE NETWORK

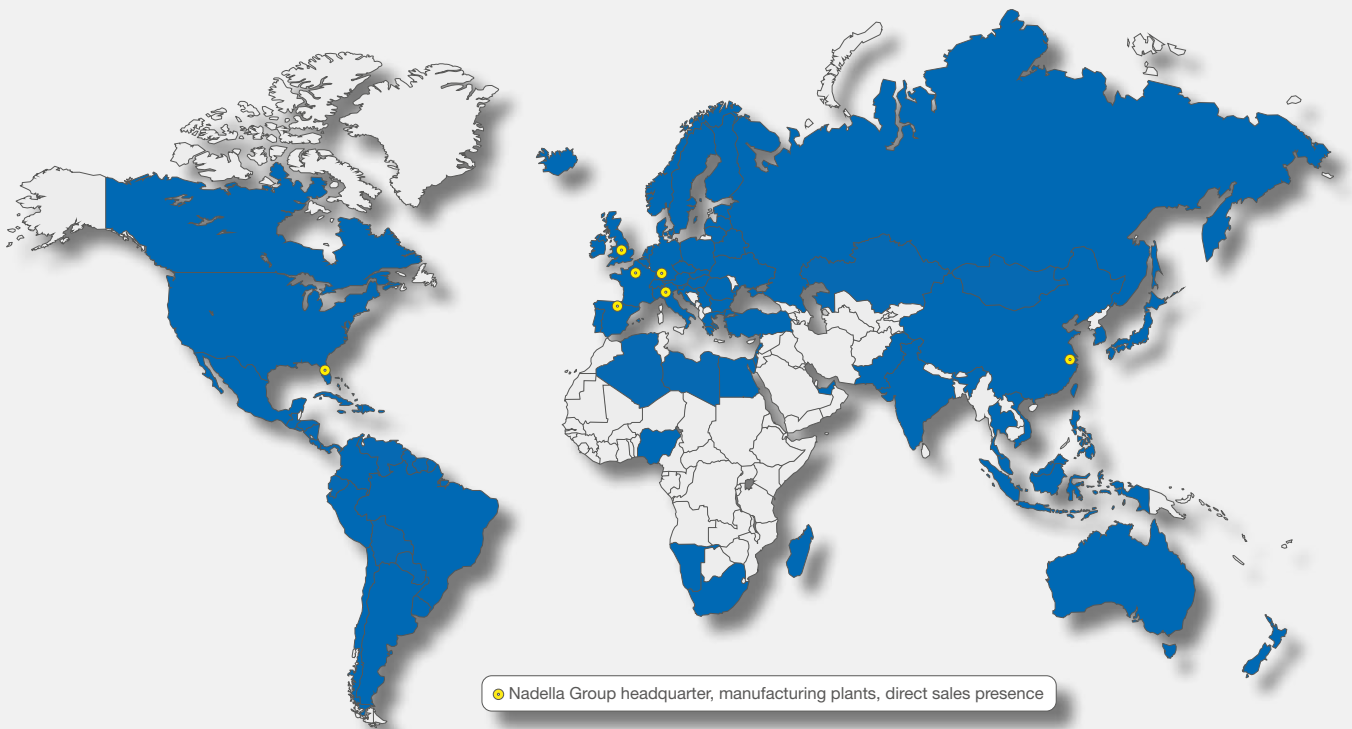

BRANCHES AND CONTACTS

NADELLA S.p.A.
Italy

Via Melette, 16
20128 Milano
Tel.: +39 02 27 093
Fax: +39 02 257 64 79
customer.service@nadella.it
www.nadella.it

NADELLA S.A.
Spain

Poligono Industrial Erratzu
Parcela G3. Pabellón 221 - Apdo.65
E-20130 Urnieta - Gipuzkoa
Tel. +34 943 336 370
ventas@nadella.es
www.nadella.com

NADELLA GmbH
Germany

Rudolf-Diesel-Str. 28
71154 Nufringen
Tel.: +49 7032 9540-0
Fax: +49 7032 9540-25
info@nadella.de
www.nadella.de

DURBAL Metallwarenfabrik GmbH - Germany

Verrenberger Weg 2
74613 Öhringen
Tel.: +49 7941 9460-0
Fax: +49 7941 9460-90
info@durbal.de
www.durbal.de

NADELLA Inc.
United States

14115 - 63 Way North
Clearwater - Florida 33760-3621
Tel.: +1 844-537-0330 (toll-free)
Fax: +1 844-537-0331
info@nadella.com
www.nadella.com

CHIAVETTE UNIFICATE S.p.A.
Italy

Via G. Brodolini 6-8-10
40069 Zola Predosa, Bologna
Tel.: +39 051 75 87 67
Fax: +39 051 75 47 80
tescubal@chiavette.it
www.chiavette.com

NADELLA Linear Shanghai Co. Ltd. - China

Room D314, No. 245 Xinjunhuan
RoadMinhang, Shanghai 201114
Tel.: +86 21 5068 3835
Fax: +86 21 5038 7725
info@nadellalinear.com
www.nadella.cn.com

SHUTON S.A.
Spain

Poligono Industrial Erratzu
C/Subino, 5 - 01170 LEGUTIANO
Tel.: +34 945 465 629
Fax: +34 945 465 610
shuton@shuton.com
www.shuton.com

NADELLA Sarl
France

12 Parvis Colonel Arnaud Beltrame
Hall A 4ème étage
78000 Versailles
Tel.: +33 (0)1 7319 4048
service.client@nadella.fr
www.nadella.fr

HUSILLOS IPIRANGA
Spain

Poligono Industrial Erratzu
Parcela G3. Pabellón 221 - Apdo.65
E-20130 Urnieta - Gipuzkoa
Tel. +34 943 336 370
info@ipirangahusillos.com
www.ipirangahusillos.com

DISTRIBUTORS COVERAGE

Austria	China	France	India	Korea	Portugal	Slovakia	Switzerland
Belgium	Czech Republic	Germany	Ireland	Netherlands	Romania	Slovenia	Taiwan
Brazil	Denmark	Great Britain	Israel	Norway	Russia	Spain	Turkey
Canada	Finland	Hungary	Italy	Poland	Singapore	Sweden	United States

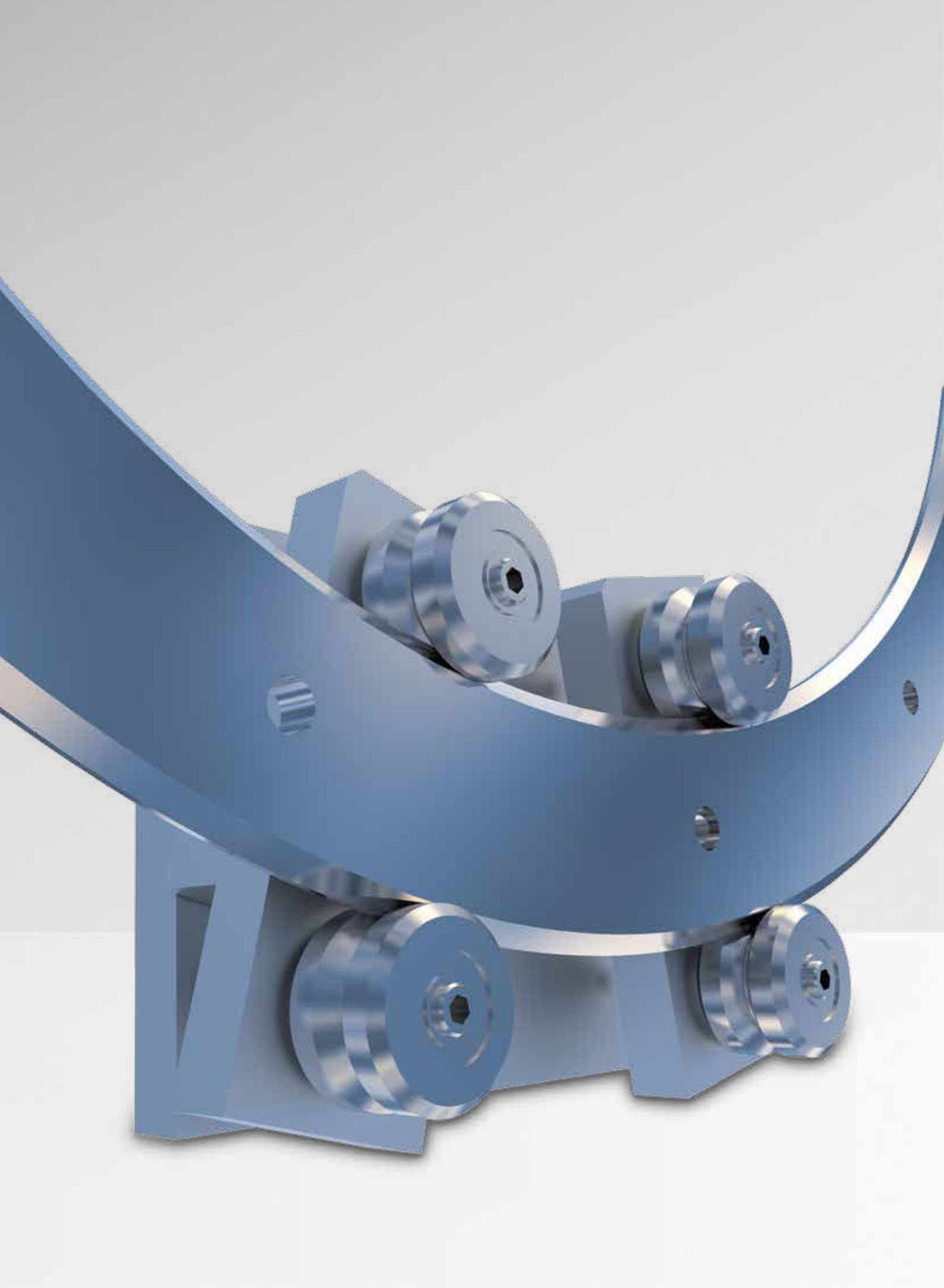













PRODUCT OVERVIEW



PAGE 10	2.1 HEAVY-LINE
PAGE 11	2.2 ROLBLOC
PAGE 11	2.3 V-LINE
PAGE 12	2.4 MULTI-MOTION-LINE
PAGE 13	2.5 C-LINE
PAGE 13	2.6 BASE-LINE
PAGE 14	2.7 FLEXI-LINE 645
PAGE 15	2.8 U-LINE





PRODUCT OVERVIEW

HEAVY-LINE

For medium-heavy loads		PAGE
Guide rails GU ... M, GU ... MT		18
Guide rollers RKU		19
Guide wheels FKU		20
Floating guide rollers RKUL		21
Lubricator LUBU		22
Guide pins SAG		23
For medium-heavy loads / dirty environment		
Guide GP ... MC		24
Guide rails GP ... M		25
Guide rollers PK		26
Guide wheels FK		27
Guide rollers GC		28
Cam followers FG / FGU		30
Lubricator LUBP		32

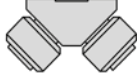





2.2

ROLBLOC

For medium-heavy loads / dirty environment		PAGE
Guide rails GU ... M, GU ... MT		39
Carriages BL		40
Carriages BL ... DS with discharge system		41
Adjustment plates PR		42
Wipers RPT		43
Lubricator LUBL for Rolbloc		43

2.3



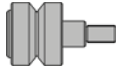



V-LINE

For any application		PAGE
Guide rails FS ... MT		48
Guide rails FS ... M		49
Guide rails FSH ... MT, FSX ... MT		50
Guide rails FSH ... M, FSX ... M		51
Guide rails FSHZ - FSXZ		52
Guide rollers FR ... EU		54
Guide rollers FR ... EU AS, FR ... EU AZ		55
Guide rollers FRN ... EI		56

2.3





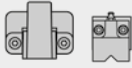

PRODUCT OVERVIEW

V-LINE

For medium-heavy loads		PAGE
Guide rollers RKY, RKX		57
Guide wheels FKY, FKX		58
Floating guide rollers FRL ... EU		59
Floating guide rollers RKXL, RLYL		60
Spacers for guide rollers FS / FSH		61
Pinion PZ		62
Lubricator LUBY, LUBX, LUBZ		63-64-65

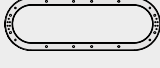
2.4

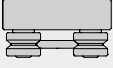
MULTI-MOTION-LINE











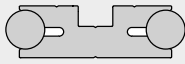

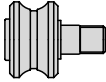
For any application		PAGE
Circular rails FSR ... M		73
Alignment blocks for FSR		74
Oval circuit FSR0		75
Ring circuit FSRQ		76
Carriages with fixed guide rollers T4R		77
Steering carriage T4R ...		78
Lubricator LUBR		79

C-LINE

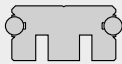
For light-medium loads		PAGE
Guide rails LS		90
Guide rollers RCS		91
Guide rollers RAS		92
Guide rollers RCN		93
Guide rollers RAN		94
Carriages C3 RCS, C3 RAS, C3 RYS		95
Carriages C4 RCS, C4 RAS, C4 RYS		96
Carriages C5 RCS, C5 RAS, C5 RYS		97
Carriages C3 RCN, C3 RAN, C3 RYN		98
Carriages C4 RCN, C4 RAN, C4 RYN		99
Carriages C5 RCN, C5 RAN, C5 RYN		100
Carriages C6 RCN, C6 RAN, C6 RYN		101



PRODUCT OVERVIEW

BASE-LINE

For medium loads and corrosive environment		PAGE
Guide rails DC		105
Guide rails C		106
Guide rollers PFV		107-108
Guide rollers RKO		110
Carriages T4 PFV		111
Wiper NAID		112
Lubricator LUBC		113
For light to medium loads		
Guide rails FWS		114
Guide rails FWH		115
Guide rollers FR ... EU		117
Guide rollers FR ... EU AS, FR ... EU AZ		117
Floating guide rollers FRL ... EU		118
Carriage T4 FR		119













2.7

FLEXI-LINE 645

For light-medium loads		PAGE
Guide rails FWN		125
Carriage TA4, TB4		126

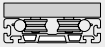
2.8

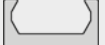
U-LINE

For light-medium loads		PAGE
Guide rails LM	 	134
Guide rollers RCL, RCP, PFV		135
Guide rollers RAL		136
Guide rollers GLA		137
Carriage C3 RCL, C3 RAL, C3 RYL		138
Carriage C4 RCL, C4 RAL, C4 RYL		139
Carriage T4 RCL, T4 RCP, T4 PFV + T4 RAL, T4 RY	 	140
Lubricator LUBM		141
Guide rails LML		142
Carriage C3 RCL 16 NX + Carriage C4 RCL 16 NX	 	143

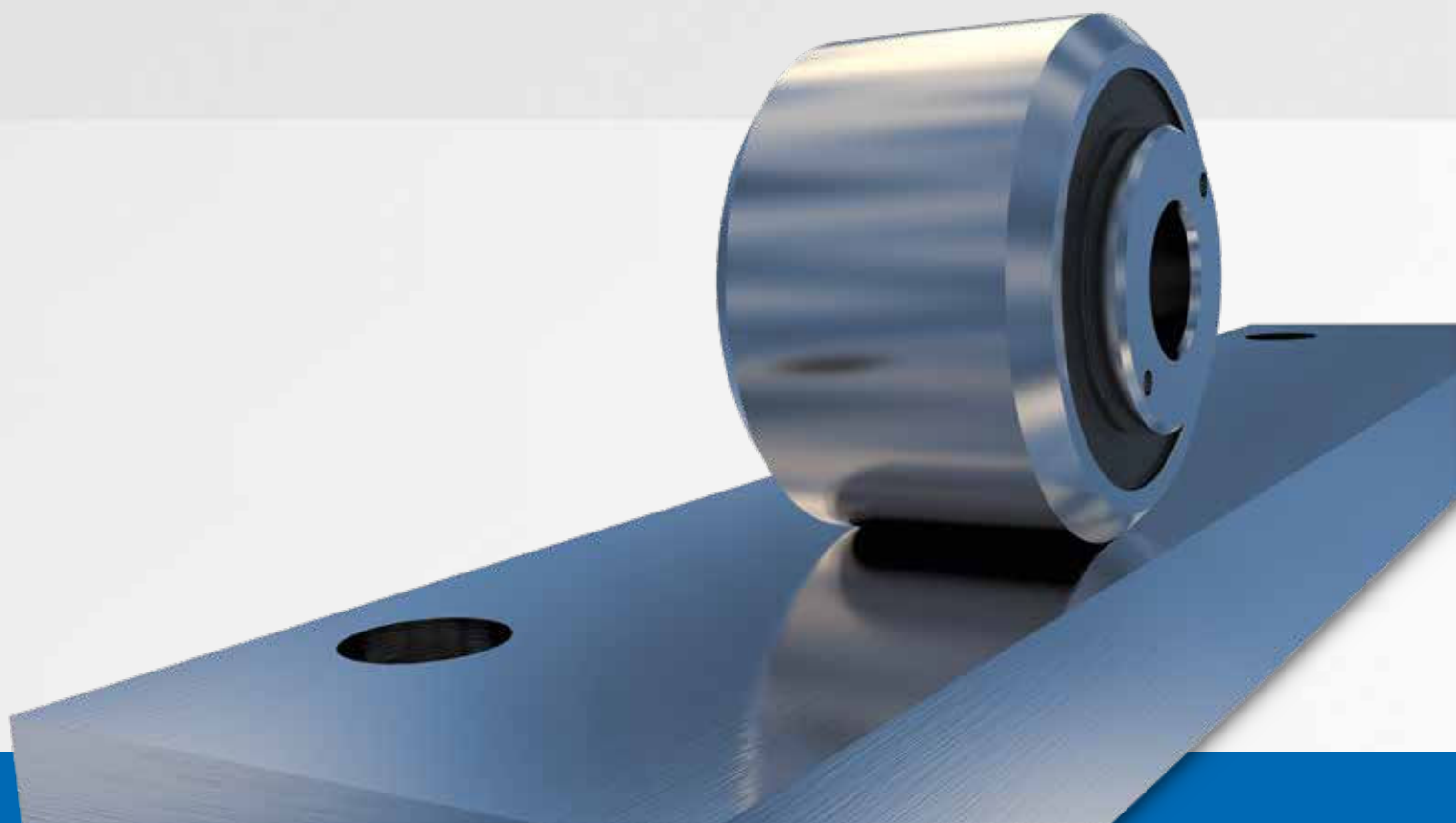
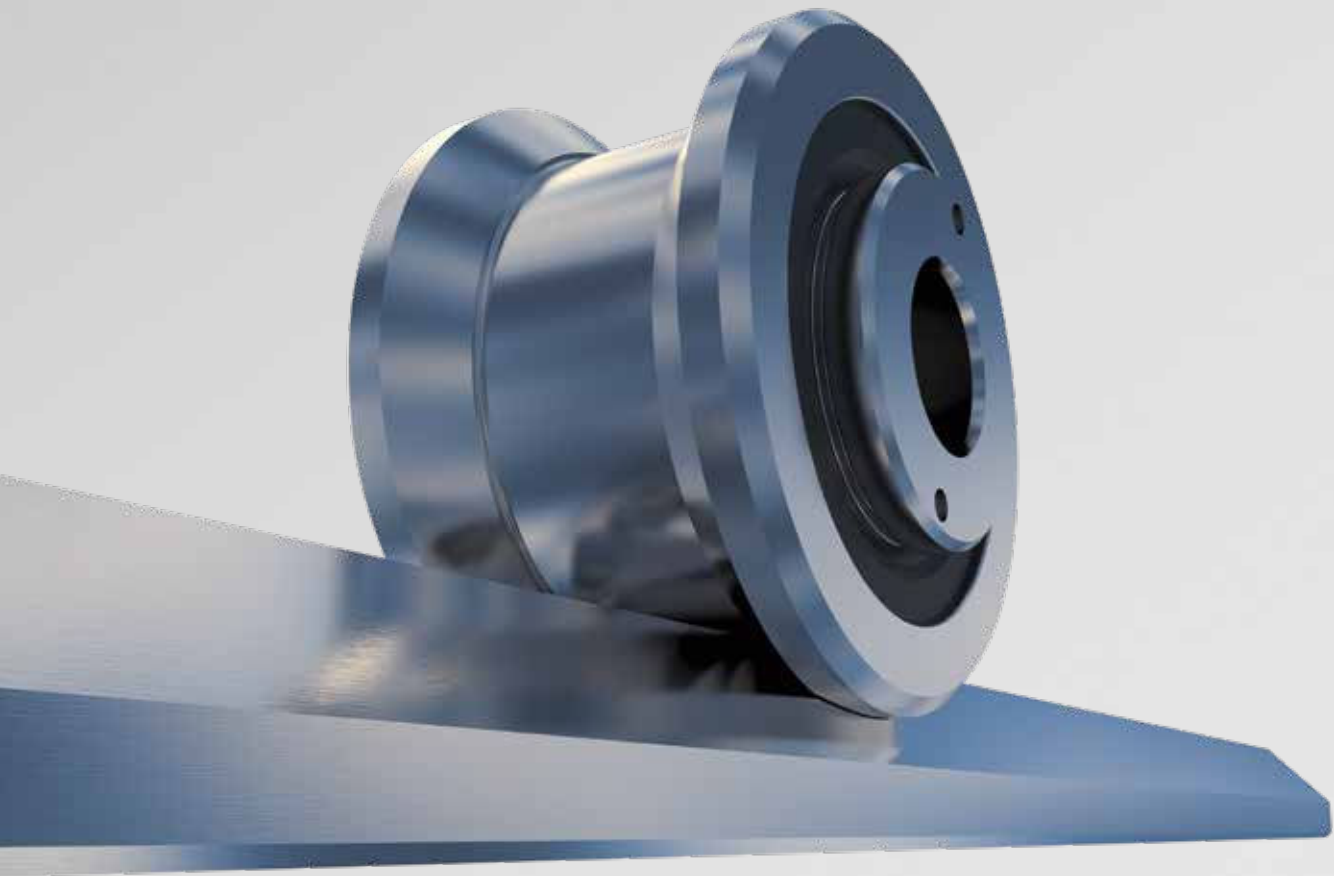

HEAVY-LINE

3

PAGE 18

3.1 SISTEMI GU

For medium-heavy loads

- Guide rails GU ... M, GU ... MT
- Guide rollers RKU
- Guide wheels FKU
- Floating guide rollers RKUL
- Lubricator LUBU
- Guide pins SAG
- Guide rollers combinations

PAGE 24

3.2 GP SYSTEM

For medium-heavy loads / dirty environment

- Guide rails GP ... MC
- Guide rails GP ... M
- Guide rollers PK
- Guide wheels FK
- Guide rollers GC
- Cam followers FG (needle) and FGU (roller)
- Lubricator LUBP

PAGE 33

3.3 GUIDE ROLLERS COMBINATIONS

PAGE 34

3.4 MOUNTING EXAMPLES

HEAVY-LINE – GU SYSTEM

GUIDE RAILS GU ... M, GU ... MT

The longitudinal slot, made with + 0.05 tolerance, permits using reference elements SAG for guide positioning.



GU ... MT

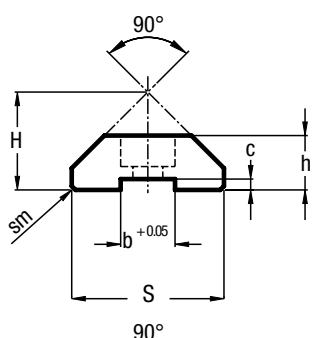

GU ... M

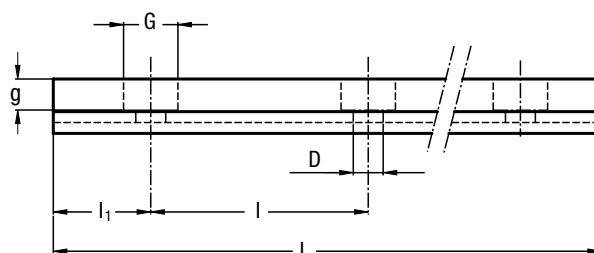
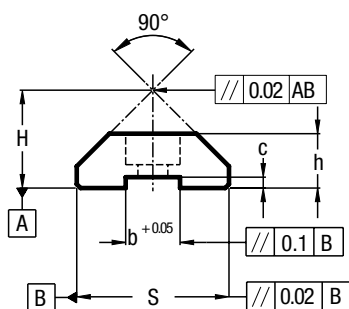

Type	Dimensions (mm)											Weight ¹⁾ (kg/m)
	H ± 0.05	h ± 0.05	S ± 0.05	D + 0.1	G	g	b + 0.05	c ± 0.05	sm	l	l ₁	
GU 28 MT	19	11	28.8	5.5	10	5.7	10	2.5	0.7 x 45°	90	30	1.97
GU 35 MT	23.9	15.7	35.5	6.6	11	6.8	10	3.8	1 x 45°	90	30	3.35
GU 50 MT	35.5	21	50.8	11	18	11	16	4.3	1 x 45°	90	30	6.89

Max. length in single element L = 6000 mm.
Longer rails are made by juxtaposing several elements with ground end.

1) Weight without holes

Type	Dimensions (mm)										Weight ²⁾ (kg/m)
	H ± 0.05	h ± 0.05	S ± 0.05	D + 0.1	G	g	b + 0.05	c ± 0.05	l	l ₁	
GU 28 M	18	10	28	5.5	10	5.7	10	2	90	30	1.8
GU 35 M	23	15	35	6.6	11	6.8	10	3.3	90	30	3.2
GU 50 M	34.5	20	50	11	18	11	16	3.8	90	30	6.8

Max. length in single element L = 4020 mm.
Longer rails are made by juxtaposing several elements with ground end.

2) Weight without holes

RAILS FINISHING

- Drawn, induction hardened and sandblasted tracks (MT)
- Drawn, induction hardened and ground (M)
- Induction hardening on raceways only

OPTIONAL FEATURES

- Ground one end: side of the first hole (1R), side of the last hole (2R)
- Ground both ends (RR)
- Chemical nickel-plating (NW)

HOLE LAYOUT

- Holes according to catalogue (SB)
- Finishes to drawing (NZ)
- Without holes (NF)

Example of standard designation: GU 35 MT 4300 SB

3.1

GUIDE ROLLERS RKU

Guide rollers with tapered roller bearings.
The sides of the race are convex with radius $R = 400$.

Available in stainless steel version.



CONCENTRIC

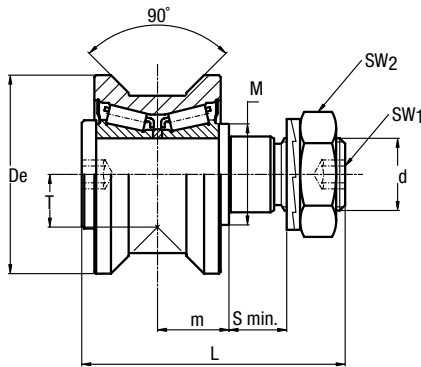

ECCENTRIC

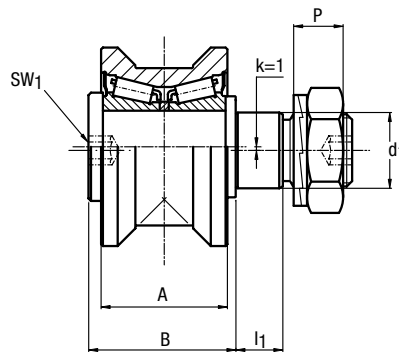

Type		Dimensions (mm)														
concentric	eccentric	De	d ₁ ¹⁾	d	T	m	S min.	P	L	A	B	I ₁	M	SW ₁	SW ₂	k
RKU 55	RKUR 55	55	21	M20 x 1.5	14.6	19.8	15	13.4	73	35	41	14	28	8	30	1
RKU 65	RKUR 65	65	27	M24 x 1.5	18	20.8	19	15.4	83	37	44	18	35	10	36	1
RKU 75	RKUR 75	75	36	M30 x 1.5	23.7	27	19	21.6	100	45	55	18	44	12	46	1
RKU 95	RKUR 95	95	38	M36 x 1.5	25.5	30	24	24.6	115	53 56 ²⁾	62	23	50	14	55	1
RKU 115	RKUR 115	115	42	M36 x 1.5	33.5	34	33	24.6	135	60 63 ²⁾	70	32	56	14	55	1

1) Housing bore tolerance: H7

2) Dimensions relating to the stainless-steel rollers (suffix NX)

Type		Dynamic load (N)	Limit loads (N)		Life coefficients		Torque wrench settings ⁴⁾ (Nm)	Weight (kg)
		C _w ³⁾	Radial F _r	Axial F _a	X	Y		
RKU 55	RKUR 55	42000	11900	3900	1	4	80	0.6
RKU 65	RKUR 65	48000	17000	6900	1	3.7	160	0.9
RKU 75	RKUR 75	69000	28500	10200	1	3.4	300	1.6
RKU 95	RKUR 95	134000	29000	12700	1	4.5	450	2.8
RKU 115	RKUR 115	190000	45000	17900	1	4.4	450	4.9

3) C_w basic load for 100 km

4) The torque wrench settings are given for non-lubricated threads; for lubricated threads, multiply figure by 0.8

- Standard seals: material NBR, RS type
- On request, the guide rollers can be supplied with external parts in stainless steel (suffix NX) and with Viton seals for operating temperatures up to 120°C (suffix V, not available for RKU 115). Internal rolling elements in standard bearing steel
- The guide rollers include self-locking washers and hexagonal nut (DIN 439B) for fitting
- Pressure angle α for load calculation: 45°

HEAVY-LINE – GU SYSTEM

GUIDE WHEELS FKU

Guide wheel with tapered roller bearings.
The sides of the race are convex with radius $R = 400$.

Available in stainless steel version.

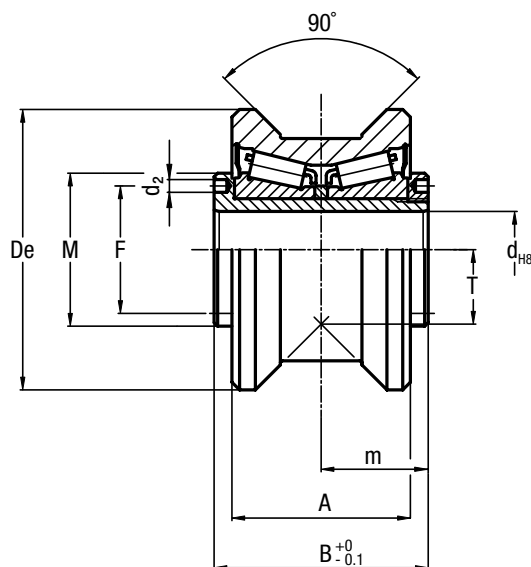

Type	Dimensions (mm)								
	De	d	T	m	A	B	F	d ₂ ²⁾	M
FKU 55	55	15	14.6	21	35	42	25	2.5	30
FKU 65	65	20	18	22.5	37	45	29	3	35
FKU 75	75	25	23.7	28	45	56	37	4	44
FKU 95	95	28	25.5	32	53 56 ¹⁾	64	42	4	49
FKU 115	115	35	33.5	36	60 63 ¹⁾	72	52	4	59

1) Dimensions relating to the stainless-steel rollers (suffix NX)

2) To prevent rotation between roller and shaft a pin can be fitted in one of the holes "d2" positioned in the side flange

Type	Dynamic load (N)	Limit loads (N)		Life coefficients		Weight (kg)
	C _w ³⁾	Radial F _r	Axial F _a	X	Y	
FKU 55	42000	11900	3900	1	4	0.5
FKU 65	48000	17000	6900	1	3.7	0.6
FKU 75	69000	28500	10200	1	3.4	1.2
FKU 95	134000	29000	12700	1	4.5	2.3
FKU 115	190000	45000	17900	1	4.4	3.9

3) C_w = Basic load for 100 Km

- Viton seals for operating temperatures up to 120°C (suffix V) on request, not available for FKU 115.
- On request the guide rollers can be supplied with external parts in stainless steel (suffix NX). Internal rolling elements in standard bearing steel
- Pressure angle α for load calculation: 45°
- Standard seals: material NBR, RS type

3.1

FLOATING GUIDE ROLLERS RKUL

Floating guide rollers with tapered roller bearings.

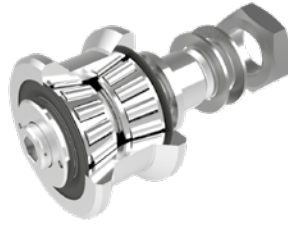

Available in stainless steel version.



CONCENTRIC

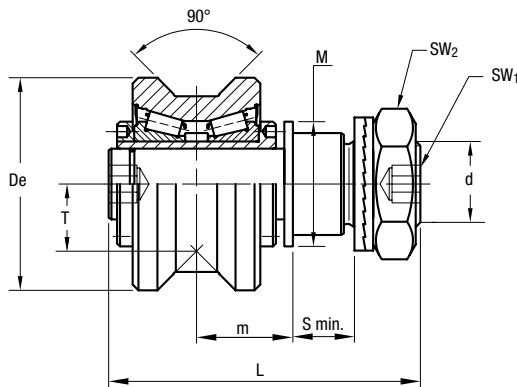

ECCENTRIC

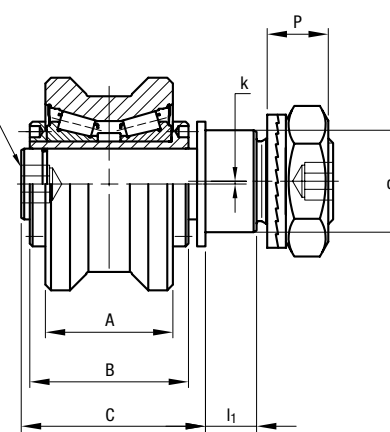

Type		Dimensions (mm)																
concentric	eccentric	De	d ₁ ¹⁾	d	T	m ²⁾ min.	m ²⁾ max.	S min.	P	L	A	B	C	I ₁	M	SW ₁	SW ₂	k
RKUL 55	RKULR 55	55	21	M20 x 1.5	14.6	24	30	15	13.4	83	35	42	51	14	30	8	30	1
RKUL 65	RKULR 65	65	27	M24 x 1.5	18	25.5	31.5	19	15.4	93	37	45	54	18	35	10	36	1
RKUL 75	RKULR 75	75	36	M30 x 1.5	23.7	31	37	19	21.6	110	45	56	65	18	44	12	46	1
RKUL 95	RKULR 95	95	38	M36 x 1.5	25.5	36	43	24	24.6	128	53 56 ³⁾	64	75	23	49	14	55	1
RKUL 115	RKULR 115	115	42	M36 x 1.5	33.5	40	47	33	24.6	148	60 63 ³⁾	72	83	32	59	14	55	1

1) Housing bore tolerance: H7

2) To ensure a safe and proper functioning the dimension m must not be higher than m max.

3) Dimensions for stainless steel (NX) version

Type		Dynamic load (N)	Limit loads (N)	Torque wrench settings ⁵⁾ (Nm)	Weight (kg)
		C _w ⁴⁾	Radial F _r		
RKUL 55	RKULR 55	42000	3050	80	0.8
RKUL 65	RKULR 65	48000	6850	160	1.1
RKUL 75	RKULR 75	69000	11200	300	1.8
RKUL 95	RKULR 95	134000	13800	450	3.0
RKUL 115	RKULR 115	190000	24000	450	5.1

4) C_w = Basic load for 100 km

5) The torque wrench settings are given for non-lubricated threads; for lubricated threads multiply figure by 0.8

- On request the guide rollers can be supplied with external parts in stainless steel (suffix NX). Internal rolling elements in standard bearing steel
- Standard seals: material NBR, RS type
- Pressure angle α for load calculation: 45°
- On request guide rollers can be supplied with Viton seals for operating temperatures up to 120°C (suffix V, not available for RKUL 115)
- The guide rollers include self-locking washers and hexagonal nut (DIN 439B) for fitting

HEAVY-LINE – GU SYSTEM

LUBRICATOR LUBU

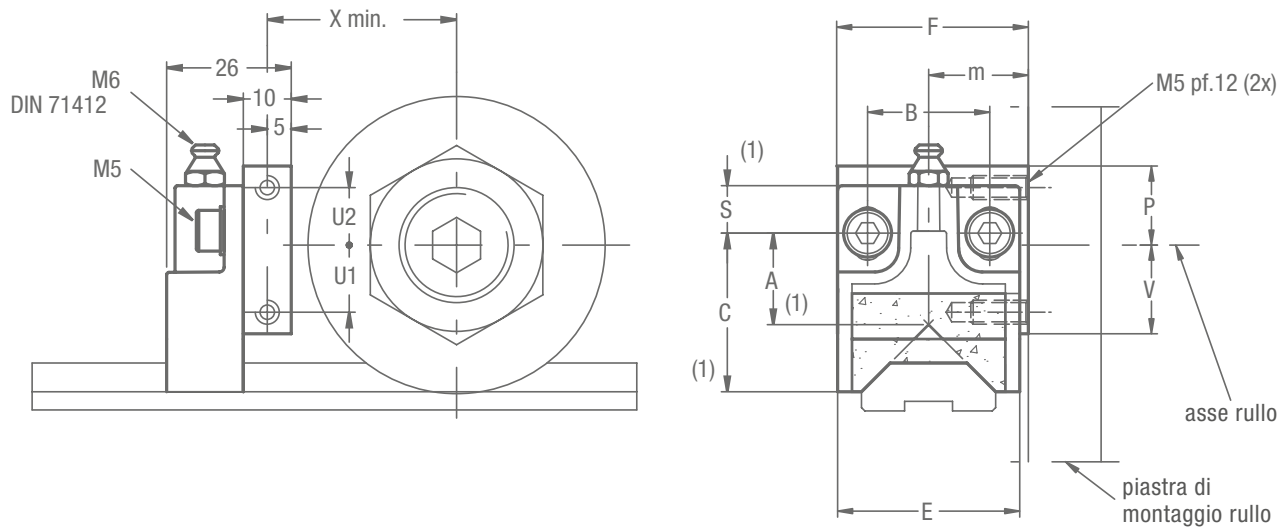
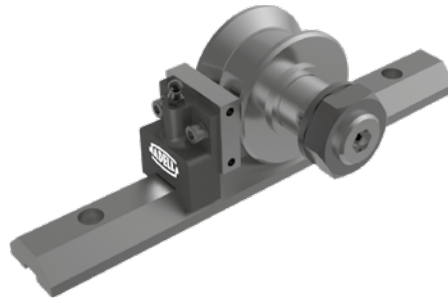

Type	Dimensions (mm)												Weight (g)	Suggested combinations
	X	U1	U2	F	m	B	S ¹⁾	C ¹⁾	A ¹⁾	E	V	P		
LUBU 55	35	12	14	40	19.8	25.5	10	34	20	38	16.5	18.5	65	RKU 55, RKUR 55, FKU 55
LUBU 65	40	14	12	40	20.8	25.5	10	34	20	38	18.5	16.5	65	RKU 65, RKUR 65, FKU 65
LUBU 75	45	19	11	50	27	25.5	10	43	25.4	44	24	16	85	RKU 75, RKUR 75, FKU 75
LUBU 95	55	21	9	60	30	30	16.5	50	24.9	58	31	19	140	RKU 95, RKUR 95, FKU 95
LUBU 115	65	30	0	63	34	30	16.5	50	24.9	58	40	10	140	RKU 115, RKUR 115, FKU 115

1) The dimension of the plastic part refers to the centre of the regulation-slot. Allows a translation of +/- 3 mm

- The lubricator is supplied with the felt already lubricated. The lubricant has a mineral oil base
- During the mounting fix the aluminium support to the rollers plate, adjust the height of the plastic part in order to put it in contact with the raceways and than block it in that position with the M5 screws

OPTIONAL FEATURES

- Felt without lubricant (D)

GUIDE PINS SAG

Guide pins for mounting alignment.

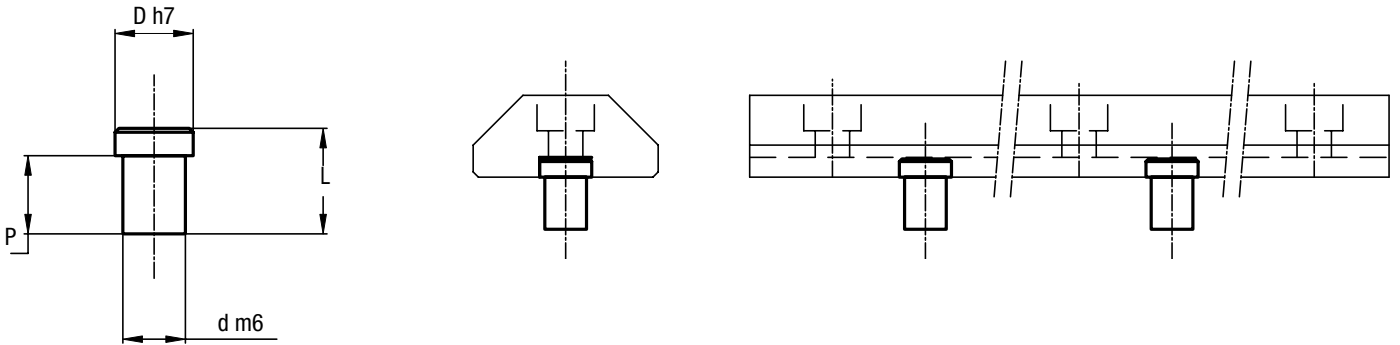

Pin type	Guide type	Dimensions (mm)			
		D	d ¹⁾	P	L
SAG 28	GU 28 MT	10	8	10	12.3
SAG 35	GU 35 MT	10	8	10	13.5
SAG 50	GU 50 MT	16	10	11.2	15

1) Housing bore tolerance: H7

GUIDE ROLLER COMBINATIONS (RKU, FKU, RKUL)

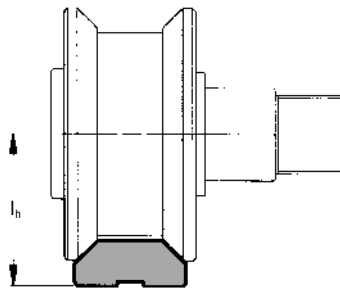

Guide	Type	Roller				
		l _h (mm)				
		RKU, FKU, RKUL 55	RKU, FKU, RKUL 65	RKU, FKU, RKUL 75	RKU, FKU, RKUL 95	RKU, FKU, RKUL 115
	GU 28 MT	33.6	37	–	–	–
	GU 28 M	32.6	36	–	–	–
	GU 35 MT	–	41.9	47.6	–	–
	GU 35 M	–	41	46.7	–	–
	GU 50 MT	–	–	–	61	69
	GU 50 M	–	–	–	60	68

HEAVY-LINE – GP SYSTEM

GUIDE RAIL GP ... MC

Rail in steel, rough ground raceways.

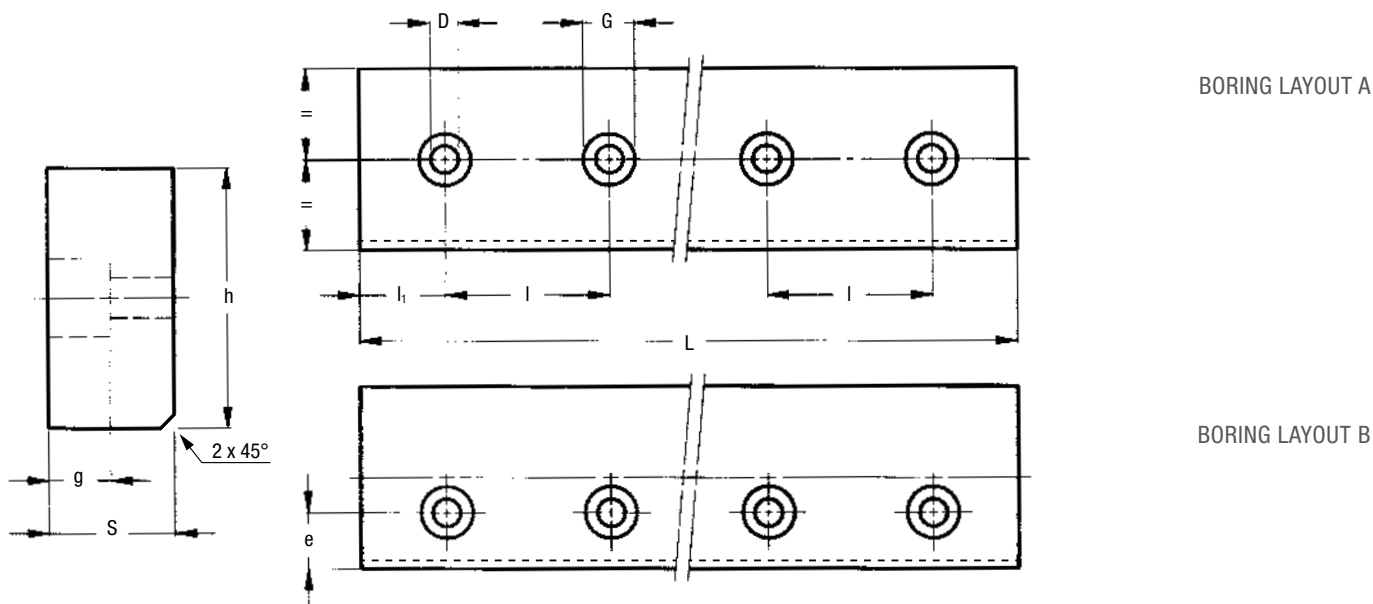
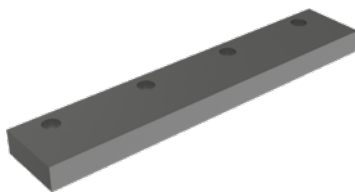

Type	Dimensions (mm)								Weight ¹⁾ (kg/m)
	h ± 0.05	S ± 0.05	D	G	g	e	l	l ₁	
GP 2626 MC	26	26	9	15	9	²⁾	120	50	5.3
GP 3232 MC	32	32	9	15	9	²⁾	150	60	8.1
GP 3617 MC	36	17	6.5	11	6.8	12.5	120	50	4.8
GP 4321 MC	43	21	9	15	9	11.5	150	60	7
GP 5050 MC	50	50	18	26	17	²⁾	180	60	19.6
GP 6222 MC	62	22	9	15	9	21	150	60	10.7
GP 7232 MC	72	32	13.5	20	13	24	180	70	18.1
GP 8222 MC	82	22	13.5	20	13	20	180	70	14.2
GP 12050 MC	120	50	18	26	17	30	180	70	47

Max. length in single element L = 5800 mm.

Longer rails are made by juxtaposing several elements with ground end.

1) Weight without holes

2) For boring layout A only

RAILS FINISHING

- Material: C60 or C45
- Induction hardened on four sides
- Surface finished by a rough grinding (MC)

HOLE LAYOUT

- Holes according to catalogue (A or B)
- Finishes to drawing (NZ)
- Without holes (NF)

OPTIONAL FEATURES

- Ground one end: side of the first hole (1R), side of the last hole (2R)
- Ground both ends (RR)
- Chemical nickel plating (NW)

Example of standard designation: GP 6222 MC 4320 ASB, GP 6222 MC 4300 B

GUIDE GP ... M

Rail in steel, ground raceways.

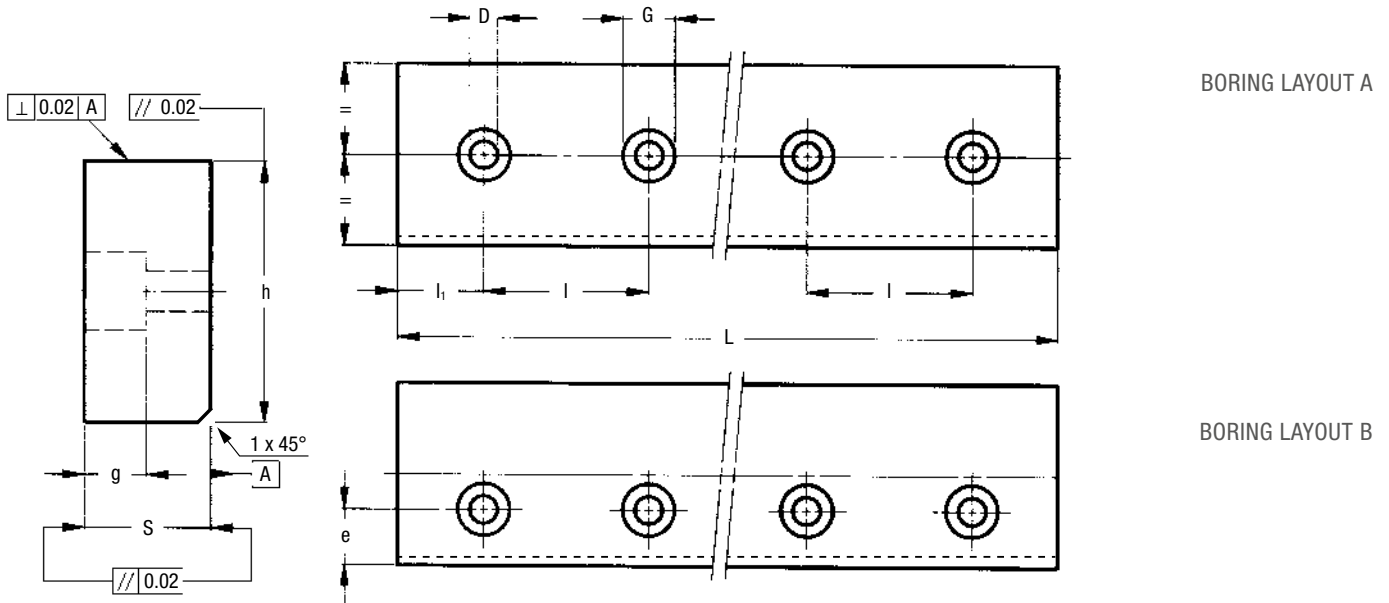
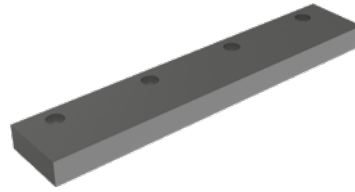

Type	Dimensions (mm)								Weight ¹⁾ (kg/m)
	h ± 0.05	S ± 0.05	D	G	g	e	l	l ₁	
GP 2525 M	25	25	9	15	8.5	²⁾	120	50	4.9
GP 3131 M	31	31	9	15	8.5	²⁾	150	60	7.5
GP 3516 M	35	16	6.5	11	6.8	12	120	50	4.4
GP 4220 M	42	20	9	15	9	11	150	60	6.5
GP 6121 M	61	21	9	15	9	20.5	150	60	10
GP 7131 M	71	31	13.5	20	12.5	23.5	180	70	17.3
GP 8121 M	81	21	13.5	20	13	19.5	180	70	13.4

Max. length in single element L = 4020 mm.

Longer rails are made by juxtaposing several elements with ground end.

Maximum length with NW treatment on request

¹⁾ Weight without holes

²⁾ For boring layout A only

RAILS FINISHING

- Material: C60 or C45
- Induction hardened on four sides
- Surface finished by a rough grinding (MC)

HOLE LAYOUT

- Holes according to catalogue (A or B)
- Finishes to drawing (NZ)
- Without holes (NF)

OPTIONAL FEATURES

- Ground one end: side of the first hole (1R), side of the last hole (2R)
- Ground both ends (RR)
- Chemical nickel plating (NW)

Example of standard designation: GP 6121 M 2070 A

HEAVY-LINE – GP SYSTEM

GUIDE ROLLERS PK

Guide roller with tapered roller bearings.

Available in stainless steel version.



CONCENTRIC

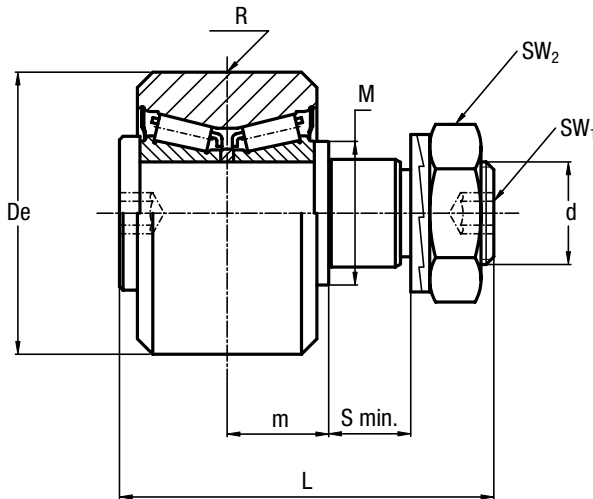

ECCENTRIC

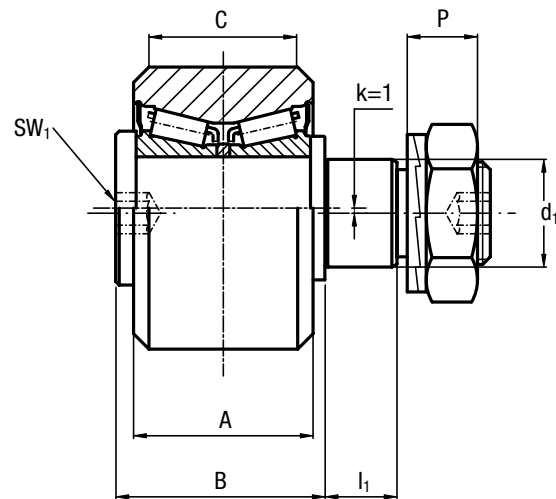

Type		Dimensions (mm)															
concentric	eccentric	De	d ₁ ¹⁾	d	m	S min.	P	L	A	B	C	R	I ₁	M	SW ₁	SW ₂	k
PK 52 C	PKR 52 C	52	21	M20 x 1.5	19.8	15	13.4	73	35	41	29	800	14	28	8	30	1
PK 62 C	PKR 62 C	62	27	M24 x 1.5	20.8	19	15.4	83	37	44	29	800	18	35	10	36	1
PK 72 C	PKR 72 C	72	36	M30 x 1.5	27	19	21.6	100	45	55	33	1200	18	44	12	46	1
PK 90 C	PKR 90 C	90	38	M36 x 1.5	30	24	24.6	115	53 56 ²⁾	62	45	1200	23	50	14	55	1
PK 110 C	PKR 110 C	110	42	M36 x 1.5	34	33	24.6	135	60 63 ²⁾	70	48	1200	32	56	14	55	1

1) Housing bore tolerance: H7

2) Dimensions relating to the stainless-steel rollers (suffix NX)

Type		Dynamic load (N)	Limit loads (N)	Torque wrench settings ⁴⁾ (Nm)	Weight (kg)
		C _w ³⁾	Radial F _r		
PK 52 C	PKR 52 C	42000	11900	80	0.6
PK 62 C	PKR 62 C	48000	22100	160	0.9
PK 72 C	PKR 72 C	69000	31300	300	1.6
PK 90 C	PKR 90 C	134000	43800	450	2.8
PK 110 C	PKR 110 C	190000	55600	450	4.9

3) C_w = basic load for 100 km

4) The torque wrench settings are given for non-lubricated threads; for lubricated threads, multiply figure by 0.8

- On request, the guide rollers can be supplied with external parts in stainless steel (suffix NX) and with Viton seals for operating temperatures up to 120°C (suffix V, not available for dimension PK 110 C). Internal rolling elements in standard bearing steel
- The guide rollers are complete with self-locking washers and hexagonal nut (DIN 439B) for fitting
- Standard seals: material NBR, RS type

3.2

GUIDE WHEELS FK

Guide wheel with tapered roller bearings.

Available in stainless steel version.

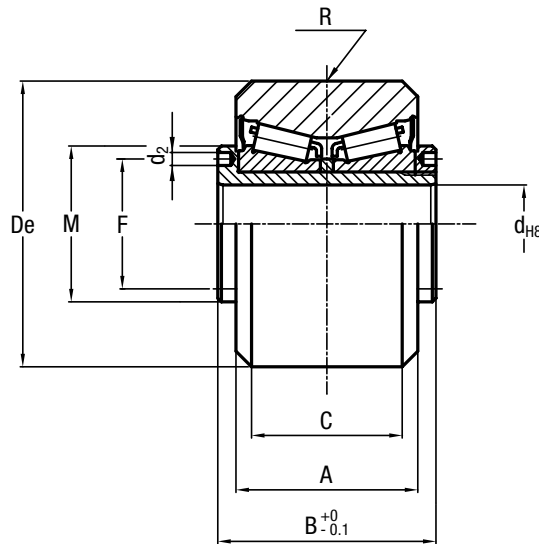

Type	Dimensions (mm)								
	D_e	d	A	B	C	R	F	d_2	M
FK 52 C	52	15	35	42	29	800	25	2.5	30
FK 62 C	62	20	37	45	29	800	29	3	35
FK 72 C	72	25	45	56	33	1200	37	4	44
FK 90 C	90	28	53 56 ¹⁾	64	45	1200	42	4	49
FK 110 C	110	35	60 63 ¹⁾	72	48	1200	52	4	59

1) Dimensions relating to the stainless-steel rollers (suffix NX)

Type	Dynamic load (N)	Limit loads (N)	Weight (kg)
	C_w ²⁾	Radial F_r	
FK 52 C	42000	11900	0.5
FK 62 C	48000	22100	0.6
FK 72 C	69000	31300	1.2
FK 90 C	134000	43800	2.3
FK 110 C	190000	55600	3.9

2) C_w = basic load for 100 km

- On request, the guide rollers can be supplied with external parts in stainless steel (suffix NX) and with Viton seals for operating temperatures up to 120°C (suffix V, not available for dimension FK 110 C). Internal rolling elements in standard bearing steel
- To prevent rotation between roller and shaft a pin can be fitted in one of the holes "d2" positioned in the side flange
- Standard seals: material NBR, RS type

HEAVY-LINE – GP SYSTEM

CAM FOLLOWERS GC..SW

Cam followers with full complement of rollers with external diameter from 16 mm to 90 mm.



Available in stainless steel version.

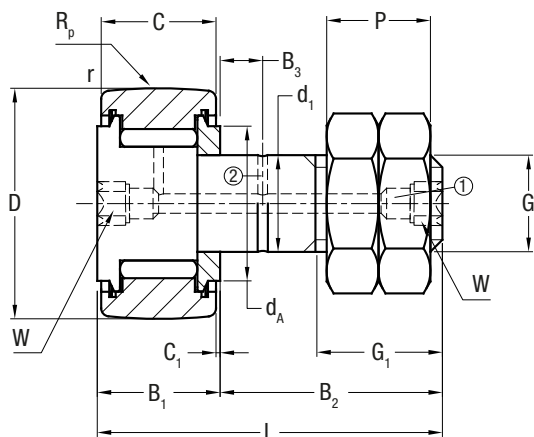

Hole 1 starting from D=22 mm
Hole 2 starting from D=30 mm

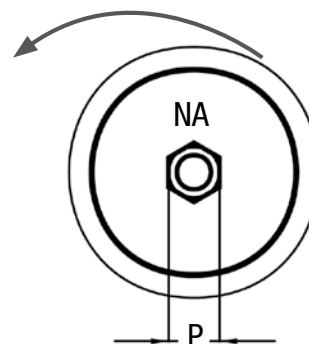

DIRECTION FOR ADJUSTMENT OF THE EXCENTER

∅ outer D mm	Designation ¹⁾	d ₁ ²⁾ mm	L mm	B ₁ mm	B ₂ mm	Threading G mm	G ₁ mm	C mm	C ₁ mm	d _A mm	B ₃ mm	r mm	R _p ³⁾ mm
	GC .. SW												
16	16	6	28,2	12,2	16,5	M6x1	8	11	0,6	13,3		0,3	500
19	19	8	32,2	12,2	20,5	M8x1.25	10	11	0,6	15,3		0,3	500
22	22	10	36,2	13,2	23,5	M10x1.25	12	12	0,6	18,2		0,3	600
24	24	10	36,2	13,2	23,5	M10x1.25	12	12	0,6	18,2		0,3	600
26	26	10	36,2	13,2	23,5	M10x1.25	12	12	0,6	20,8		0,3	600
28	28	10	36,2	13,2	23,5	M10x1.25	12	12	0,6	20,8		0,3	600
30	30	12	40,2	15,2	25,5	M12x1.5	13	14	0,6	24,8	6	0,6	700
32	32	12	40,2	15,2	25,5	M12x1.5	13	14	0,6	24,8	6	0,6	700
35	35	16	52,2	19,6	33	M16x1.5	17	18	0,8	28,8	8	0,6	800
40	40	18	58,1	21,6	37	M18x1.5	19	20	0,8	33,8	8	1	1000
47	47	20	66,1	25,6	41	M20x1.5	21	24	0,8	38,7	9	1	1200
52	52	20	66,1	25,6	41	M20x1.5	21	24	0,8	38,7	9	1	1200
62	62	24	80,1	30,6	50	M24x1.5	25	29	0,8	52	11	1	1500
72	72	24	80,1	30,6	50	M24x1.5	25	29	0,8	52	11	1	1500
80	80	30	100	37	63,5	M30x1.5	32	35	1	68	15	1	1700
85	85 ⁹⁾	30	100	37	63,5	M30x1.5	32	35	1	68	15	1	1700
90	90	30	100	37	63,5	M30x1.5	32	35	1	68	15	1	1700

1) Cam follower with stud designation

GC..SW Concentric cam follower with stud optimised profile outer ring

GCL..SW Concentric cam follower with stud cylindrical outer ring (product available on request)

GCR.. Cam follower with stud with eccentric collar

No suffix Without seal

Suffix ..EE With plastic seal, ex. GC40EESW

Suffix ..EEM With metal seal, ex. GC40EEMSW

2) Hole diameter for assembly of concentric cam follower without stud: d₁ H7

3) Convex radius in the central part to contact pressure calculation

HEAVY-LINE – GP SYSTEM

CAM FOLLOWERS GC..SW

3.2

Cam followers with full complement of rollers with external diameter from 16 mm to 90 mm.



Available in stainless steel version.

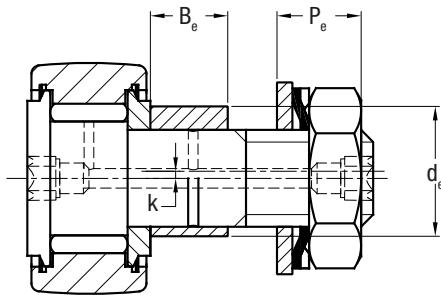

from GCR16SW to GCR52SW

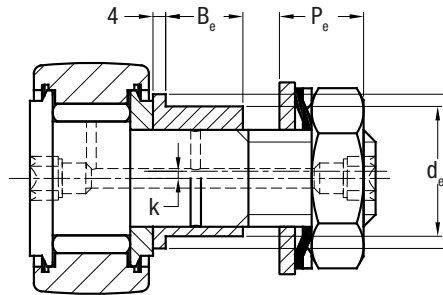

from GCR62SW to GCR90SW

W mm	P ⁷⁾ mm	Eccentric bearing					Load coefficients (N) ⁶⁾				Greasing speed limit with grease (min ⁻¹)	Weight of nut and washers Kg	Clamping torque Nm	∅ outer D mm
		d _e ^{4) 5)} mm	k ⁵⁾ mm	M ⁵⁾ mm	B _e ⁵⁾ mm	P _e ⁸⁾ mm	Din. C _{w1} ¹⁰⁾	Din. C _{w2} ¹¹⁾	Din. F _r	Stat. For.				
4	6,4	9	0,5		8	5,6	4900	4000	1200	2300	5000	0,024	3	16
4	8	11	0,5		10	6,4	5600	4800	2900	5400	4100	0,039	8	19
4	10	14	1		11	7,9	6900	6200	5300	9400	3400	0,057	20	22
4	10	14	1		11	7,9	7600	7000	5300	9800	3400	0,072	20	24
4	10	14	1		11	7,9	8600	8100	5300	9800	3000	0,08	20	26
4	10	14	1		11	7,9	9200	8900	5300	9800	3000	0,088	20	28
6	12	16	1		11	9,5	13000	12800	7900	15000	2600	0,118	26	30
6	12	16	1		11	9,5	13000	13000	7900	15000	2600	0,126	26	32
10	16	21	1,5		14	12,2	18000	18500	14000	23000	2100	0,22	64	35
12	18	24	1,5		16	13,4	22000	23600	19000	34000	1800	0,321	90	40
14	20	27	2		17,5	14,4	27000	30300	22000	35000	1500	0,5	120	47
14	20	27	2		17,5	14,4	33000	38200	22000	40000	1500	0,568	120	52
12	24	36	3	44	18	17,5	42000	51300	31000	58000	1200	1,035	220	62
12	24	36	3	44	18	17,5	46000	58800	31000	58000	1200	1,278	220	72
14	30	42	3	50	27	20,6	58000	76500	50000	93000	900	2,074	450	80
14	30	42	3	50	27	20,6	61000	81900	50000	93000	900	2,235	450	85
14	30	42	3	50	27	20,6	63000	86100	50000	93000	900	2,435	450	90

4) Hole diameter for assembly of the eccentric cam follower without stud: d_e H7

5) Dimensions of the eccentric bearing.

6) Fr and For load for cam follower without stud, with no eccentric collar.

7) The GC concentric cam followers with stud are supplied with two clamping nuts.

8) GCR eccentric cam followers with stud are supplied with eccentric bearing already fitted, clamping nut, cogged washer and support surface washer.

9) Product available on request

10) C_{w1}: Calculation coefficient for service life with 1 million rpm base

11) C_{w2}: Calculation coefficient for the duration with base 100 km

HEAVY-LINE – GP SYSTEM

CAM FOLLOWERS FG NEEDLE AND FGU ROLLER



FG series without seals
FG ... EEM series with metal shields

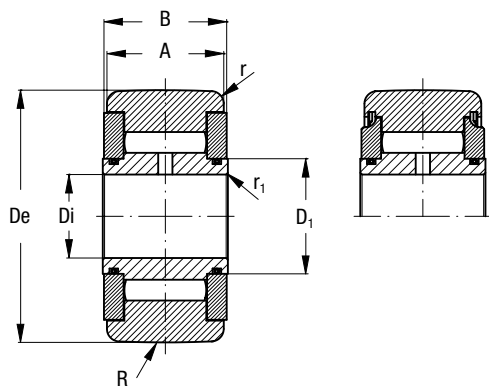

FGU
FGU ... MM series: with metal shields

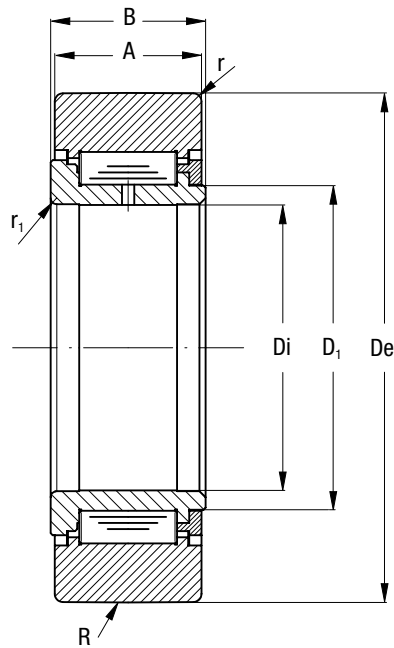

3.2

Type	Dimensions (mm)								
	D _e	D _i	A	B max.	D ₁	M min. ¹⁾	r min.	r ₁ min.	R
FG 6 19 SW	19	6	11	12	8.5	12	0.3	0.3	160
FG 10 30 SW	30	10	14	15	13.8	19.5	0.6	0.3	250
FG 12 32 SW	32	12	14	15	16	21.5	0.6	0.3	250
FG 15 35 SW	35	15	18	19	18.7	24	0.6	0.3	320
FG 17 40 SW	40	17	20	21	22	28	0.6	0.3	400
FG 20 47 SW	47	20	24	25	25.7	32.5	1	0.3	500
FG 25 52 SW	52	25	24	25	30.5	37	1	0.3	500
FG 30 62 SW	62	30	28	29	35.2	44	1	0.3	640
FG 35 72 SW	72	35	28	29	41	50	1	0.6	640
FG 40 80 SW	80	40	30	32	46.7	56	1	0.6	800
FG 50 90 SW	90	50	30	32	59.1	69	1	0.6	800
FGU 55 100	100	55	34	36	64	75.8	1.5	0.6	800
FGU 60 110	110	60	34	36	69.5	81.5	1.5	0.6	800
FGU 65 120	120	65	40	42	74.5	86.7	1.5	0.6	900
FGU 75 130	130	75	40	42	84	97	1.5	0.6	900

1) Minimum abutment diameter recommended in case of heavy axial load or vibration

Type	Dynamic load ²⁾ (N)		Limit loads ³⁾ (N)		Speed limit grease lubrication ⁴⁾ r.p.m.
	C _{w1} ⁵⁾	C _{w2} ⁶⁾	Dyn. F	Sta. Fo	min-1
FG 6 19 SW	5600	4800	4050	6700	7600
FG 10 30 SW	13000	12800	8500	15500	4800
FG 12 32 SW	12000	12000	8300	16200	4200
FG 15 35 SW	17000	17500	12200	25600	3750
FG 17 40 SW	22000	23600	14200	31000	3150
FG 20 47 SW	27000	30300	21400	44500	2700
FG 25 52 SW	29000	33600	23600	48000	2330
FG 30 62 SW	38000	46400	38000	73000	2050
FG 35 72 SW	43000	54900	49000	90000	1800
FG 40 80 SW	52000	68600	66000	123000	1620
FG 50 90 SW	49000	66900	74000	123000	1300
FGU 55 100	72000	101500	53400	109000	1900
FGU 60 110	90000	130600	64000	129000	1770
FGU 65 120	110000	163800	89000	174000	1650
FGU 75 130	110000	167800	97000	185000	1480

2) These capacities are to be used for all types when the convex outer ring rotates directly on a cam.

They take account of the repetitive loads on the follower and consequent deformation of the outer ring

3) The load shown is limited by the strength of the outer ring when mounted in a housing

4) With oil lubrication of followers without seals FG, FGL types, these speeds can be increased by 30% for continuous rotation or up to 50% for intermittent rotation

5) C_{w1}: Coefficient to calculate the basic rating life based on one million revolutions

6) C_{w2}: Coefficient to calculate the basic rating life based on 100 km

HEAVY-LINE – GP SYSTEM LUBRICATOR LUBP

Lubrication unit for GP rails

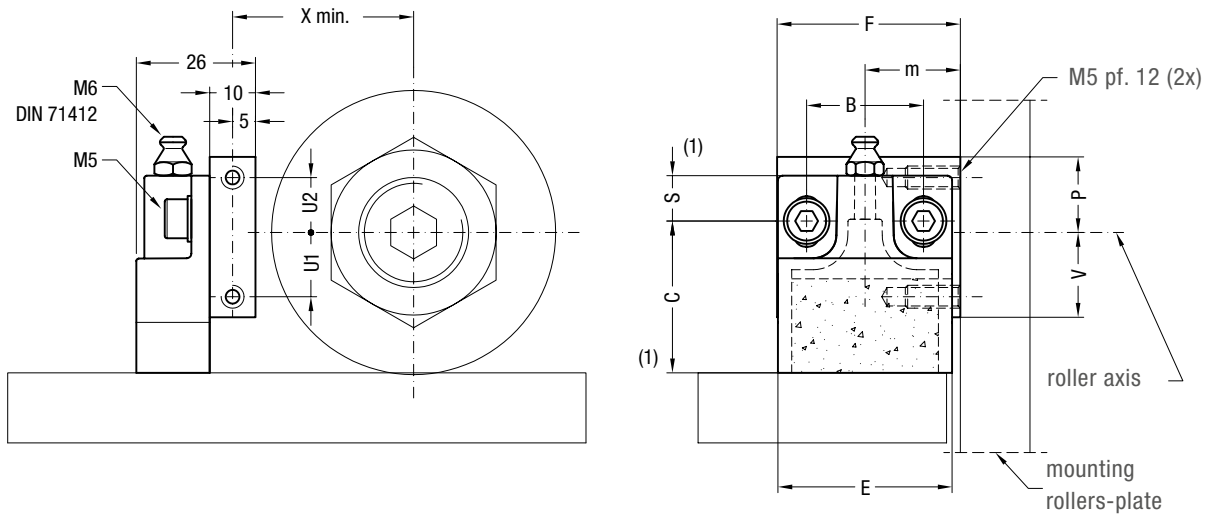
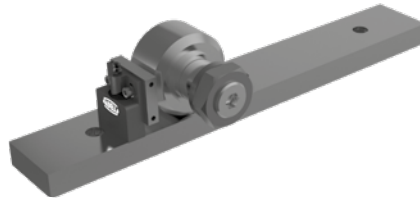

Type	Dimensions (mm)											Weight (g)	Suggested combinations
	X	U1	U2	F	m	B	S ¹⁾	C ¹⁾	E	V	P		
LUBP 52	33.5	12	14	40	19.8	25.5	10	32.5	38	16.5	18.5	65	PK 52 C, PKR 52 C, FK 52 C
LUBP 62	38.5	14	12	40	20.8	25.5	10	32.5	38	18.5	16.5	65	PK 62 C, PKR 62 C, FK 62 C
LUBP 72	43.5	19	11	50	27	25.5	10	40	44	24	16	85	PK 72 C, PKR 72 C, FK 72C
LUBP 90	52.5	21	9	60	30	30	16.5	43.5	58	31	19	140	PK 90 C, PKR 90 C, FK 90 C
LUBP 110	62.5	30	0	63	34	30	16.5	43.5	58	40	10	140	PK 110 C, PKR 110 C, FK 110 C

¹⁾ The dimension of the plastic part refers to the centre of the regulation slot. The regulation slot allows a translation of +/- 3 mm

- The lubricator is supplied with the felt already lubricated. The lubricant has a mineral oil base
- During the mounting fix the aluminium support to the rollers plate, adjust the height of the plastic part in order to put it in contact with the raceways and then block it in that position with the M5 screws

OPTIONAL FEATURES

- Felt without lubricant (D)

GUIDE ROLLERS COMBINATIONS

3.3

LAYOUT 1
HOLE PATTERN A AND B

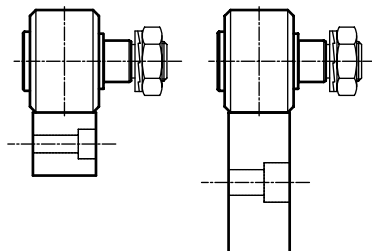

LAYOUT 2
ONLY HOLE PATTERN B

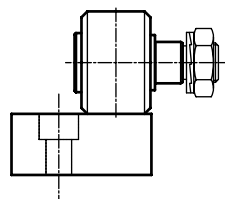

Layout 1	GC												PK / FK				
	19	22	24	26	28	30	32	35	40	47	52	62	52	62	72	90	110
GP 2626 MC / GP 2525 M	•	•	•	•	•	•	•	•	•								
GP 3232 MC / GP 3131 M										•	•	•	•	•			
GP 3617 MC / GP 3516 M	•	•	•	•	•	•	•										
GP 4321 MC / GP 4220 M						•	•	•									
GP 5050 MC															•	•	•
GP 6222 MC / GP 6121 M								•	•								
GP 7232 MC / GP 7131 M										•	•	•	•	•			
GP 8222 MC / GP 8121 M								•	•								
GP 12050 MC																•	•

Layout 1	FG / FGU													
	6 19	10 30	12 32	15 35	17 40	20 47	25 52	30 62	35 72	40 80	50 90	55 100	65 120	75 130
GP 2626 MC / GP 2525 M	•	•	•	•	•									
GP 3232 MC / GP 3131 M						•	•	•	•	•	•			
GP 3617 MC / GP 3516 M	•	•	•											
GP 4321 MC / GP 4220 M		•	•	•										
GP 5050 MC												•	•	•
GP 6222 MC / GP 6121 M				•	•									
GP 7232 MC / GP 7131 M						•	•	•	•	•	•			
GP 8222 MC / GP 8121 M				•	•									
GP 12050 MC												•	•	•

Layout 2	GC												PK / FK				
	19	22	24	26	28	30	32	35	40	47	52	62	52	62	72	90	110
GP 3617 MC / GP 3516 M	•	•	•	•	•	•	•										
GP 4321 MC / GP 4220 M							•	•	•								
GP 6222 MC / GP 6121 M							•	•	•	•	•	•	•	•			
GP 7232 MC / GP 7131 M										•	•	•	•	•	•		
GP 8222 MC / GP 8121 M															•	•	•
GP 12050 MC																•	•

Layout 2	FG / FGU														
	6 19	10 30	12 32	15 35	17 40	20 47	25 52	30 62	35 72	40 80	50 90	55 100	60 110	65 120	75 130
GP 3617 MC / GP 3516 M	•	•	•												
GP 4321 MC / GP 4220 M			•	•	•										
GP 6222 MC / GP 6121 M				•	•	•	•	•	•						
GP 7232 MC / GP 7131 M						•	•	•	•	•	•	•	•		
GP 8222 MC / GP 8121 M												•	•	•	•
GP 12050 MC												•	•	•	•

In the tables above the suggested combinations. Other combinations are possible but guide rollers must not run over the mounting holes.

HEAVY-LINE MOUNTING EXAMPLES

Guide rails type GU 35 MT and rollers type RKU 75 operated on light-alloy structure.

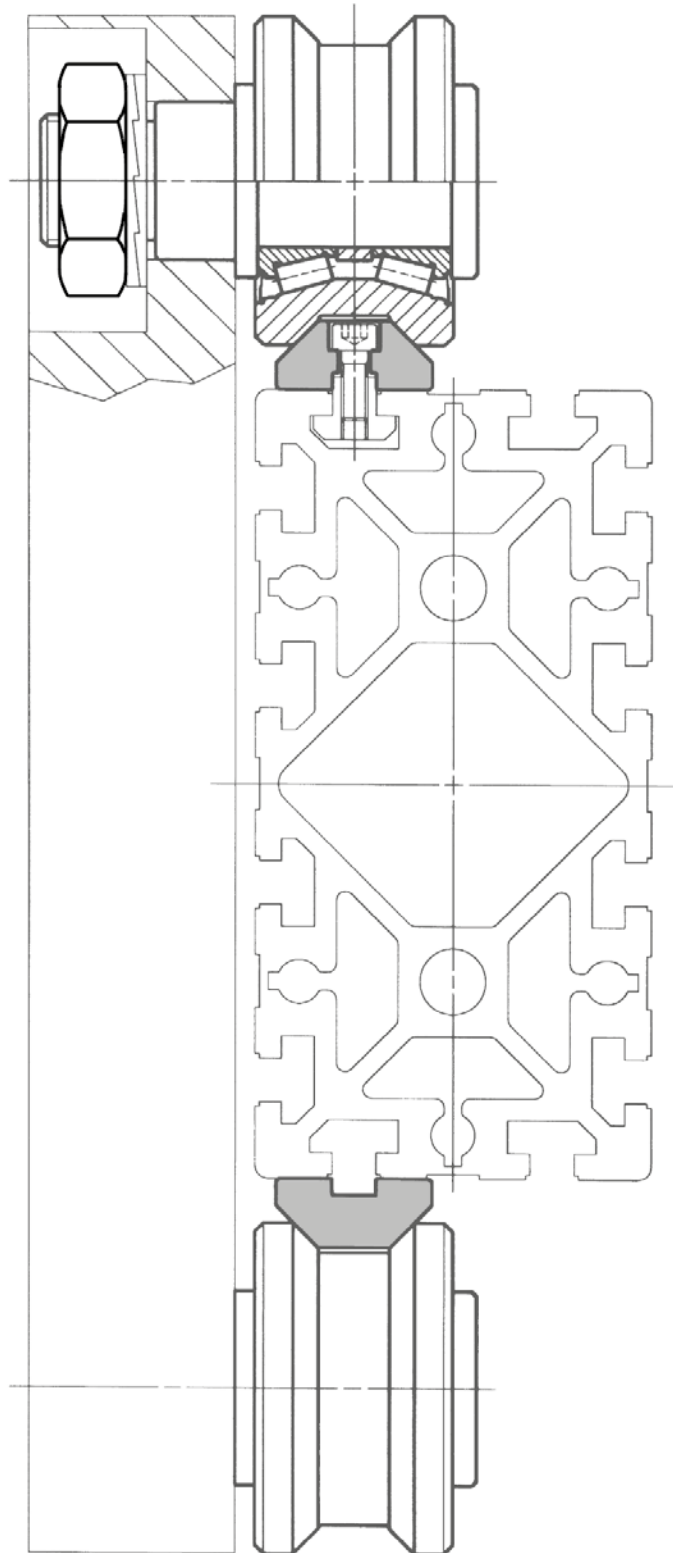

3.4

MARBLE MACHINERY Heavy-Line systems GU and GP.

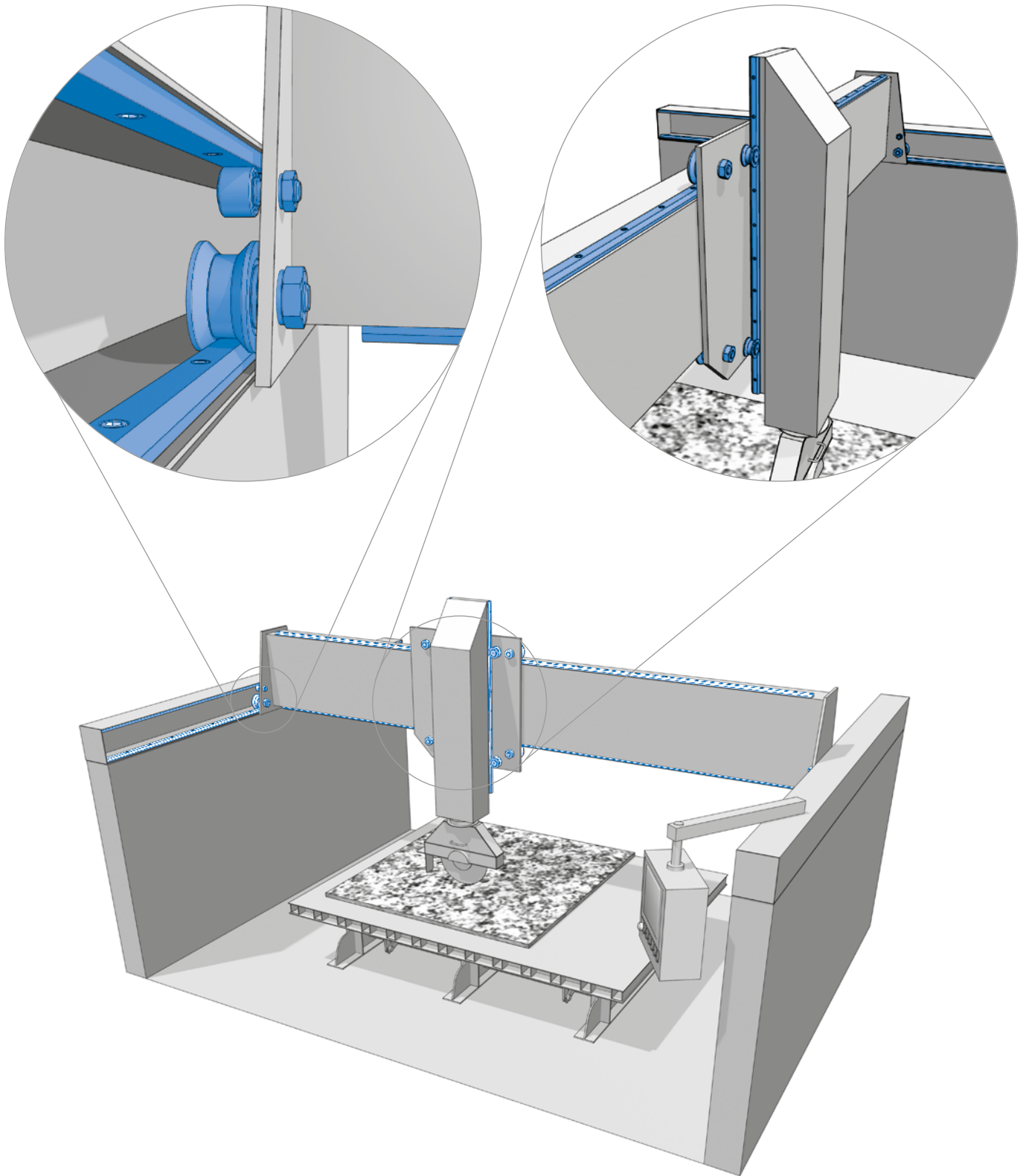



ROLBLOC



PAGE 38

4.1 ROLBLOC SYSTEM

PAGE 39

4.2 ROLBLOC

For medium-heavy loads / dirty environment

- Guide rails GU ... M, GU ... MT
- Carriages BL
- Carriages BL ... DS with discharge system
- Adjustment plates PR
- Wipers RPT
- Lubricator LUBL

PAGE 44

4.3 GUIDE / CARRIAGE COMBINATIONS

PAGE 45

4.4 MOUNTING EXAMPLES

ROLBLOC ROLBLOC SYSTEM

KEY BENEFITS

- For heavy loads and dirty environment
- Up to 15 t per carriage
- High compensation for a simple mounting
- Guide rails with different surface treatment
- Guide rollers in stainless steel version



The carriages based on Rolbloc's system are recommended for applications with heavy loads, high frequency of work and aggressive environment (dust, abrasive). For the profiled guide rollers, the contact between the rollers and the rail takes place on the ground raceways, which are inclined in respect of the rotation axis of the guide roller. Due to this inclination angle in the contact area there is a dragging proportional to the dimension of the contact area and to the value of the inclination angle. In the Rolbloc system the rotation axes of the roller guides are parallel to the raceways of the rail, with the following pure rolling. The pure rolling reduces the superficial stress and the effects of the dust between the surfaces.

CARRIAGE BL2 .., BL4 ..

Rolbloc carriages BL2 ... and BL4 ... are composed by a body in burnished steel on which are mounted two or four roller guides equipped with tapered rollers (similar to flat roller guides type PK...C). The final part of the code (that can be 52, 75 or 115) shows the external diameter of the roller guides.

ROLBLOC BL2..DS WITH DISCHARGE SYSTEM

Rolbloc carriages BL2 ... DS have a special block profile with a profiled surface close at the rail GU...M or MT. The space S is set so that during normal operation there is no contact between the block and the rail and the carriage moves on its rollers. When the load goes over the normal value the deflection of the rollers reduces the space S since there is direct contact between the rail and the block. In this way the system is protected versus extremely and or uncontrolled loads. When the extra load is removed the system returns in its normal position thanks to the rollers' elasticity.

Rolbloc in DS version is a simple and effective solution in the following applications:

- Systems that have to be blocked in a position. The blocking system, i.e. a hydraulic cylinder or a bolt used as tie beam, can push directly the carriage against the rail without component damage risk.
- Systems where high stiffness support is required in a static operation. When the block is pushed in contact with the rail the system stiffness increases and stability is given versus deformation and vibrations
- Systems that have to stand shocks and extra load that could compromise the roller resistance. This allows to select the component size on the normal load during the operation and not on the pick-force.

HOW IT WORKS

The carriage is realized with a special design that provides a gap between carriage body and rail.

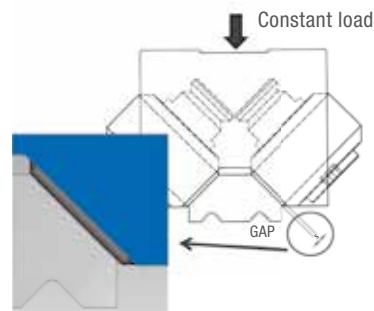

When a heavy load is applied, the rollers are free to flex until the carriage body leans on the guide, discharging on it all the load that otherwise would break the rollers. After removing the load the carriage is again able to move regularly on the rail.

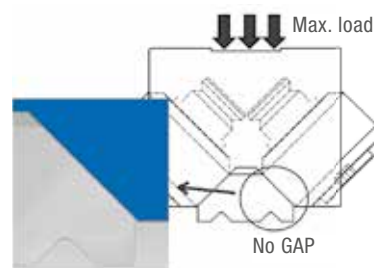
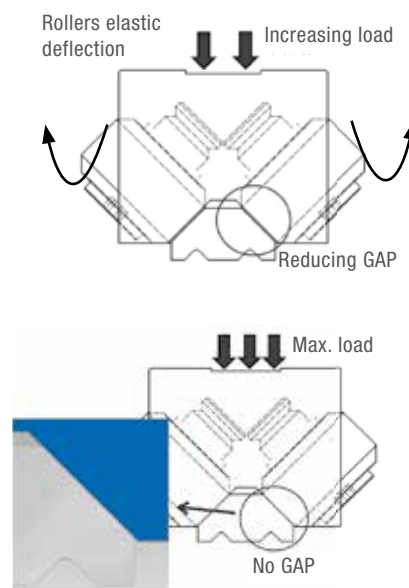

GUIDE RAILS GU ... M, GU ... MT

Rail in steel, ground raceways.

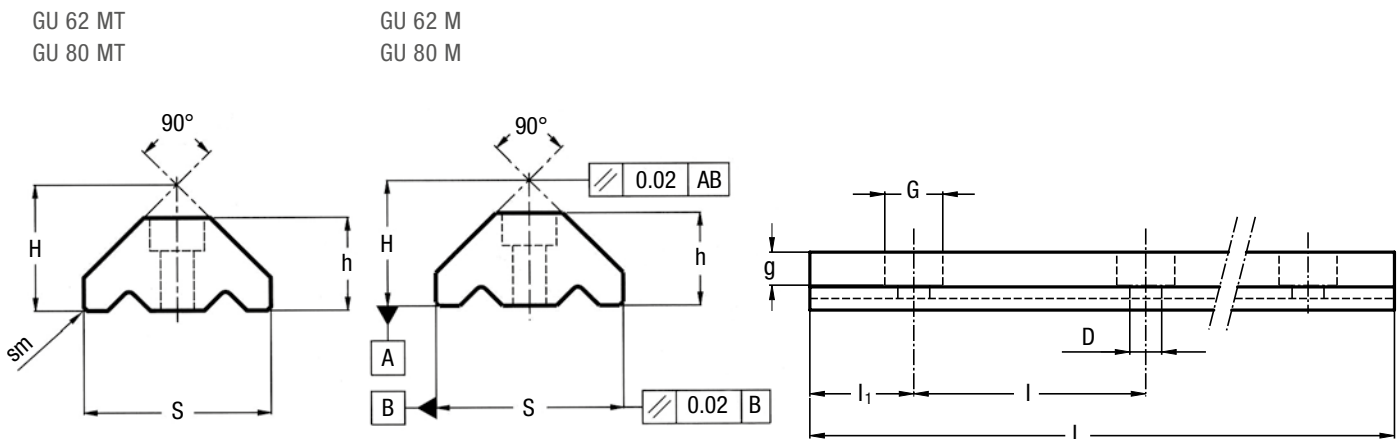

Type	Dimensions (mm)									Weight ²⁾ (kg/m)
	H ± 0.05	h ± 0.05	S ± 0.05	D + 0.1	G	g	sm	l	l ₁	
GU 62 MT	43.5	32.5	63.5	11	18	11	2 x 45°	120	30	11.80
GU 80 MT	56.7	41.5	81.5	13.5	20	13	2 x 45°	120	30	20.30

Max. length in single element L = 6000 mm.

Longer rails are made by juxtaposing several elements with ground end.

1) Weight without holes

Type	Dimensions (mm)								Weight ²⁾ (kg/m)
	H ± 0.05	h ± 0.05	S ± 0.05	D + 0.1	G	g	l	l ₁	
GU 62 M	42	31	62	11	18	11	120	30	10.9
GU 80 M	55.2	40	80	13.5	20	13	120	30	20

Max. length in single element L = 4020 mm.

Longer rails are made by juxtaposing several elements with ground end.

2) Weight without holes

RAILS FINISHING

- Drawn, induction hardened and sandblasted tracks (MT)
- Drawn, induction hardened and ground (M)
- Induction hardening on raceways only
- Holes according to catalogue (SB)
- Finishes to drawing (NZ)
- Without holes (NF)

OPTIONAL FEATURES

- Ground one end: side of the first hole (1R), side of the last hole (2R)
- Ground both ends (RR)
- Chemical nickel-plating (NW)

Example of standard designation: GU 62 MT 4300 SB

ROLBLOC CARRIAGES BL

Carriage with burnished body.



Available in stainless steel version.

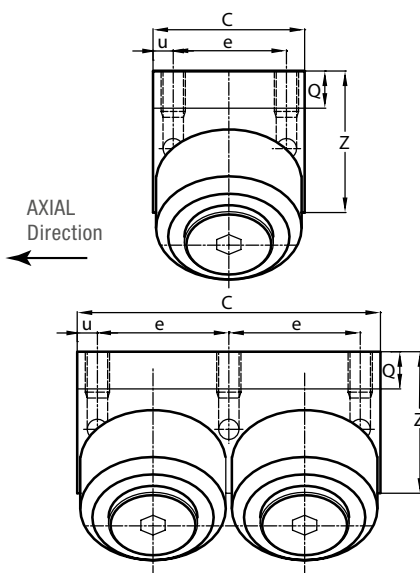
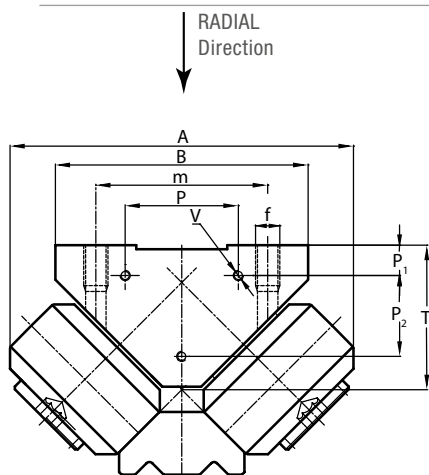

BL 2 ... two guide rollers block

BL 4 ... four guide rollers block

Type	Dimensions (mm)														Weight (kg)
	A	B ¹⁾	C	P	P ₁	P ₂	V	m	e	u	f	Q	T	Z	
BL 252	136	90	56	54	14	16	M4 x 7	70	40	8	M8	12	43	47	2.4
BL 452	136	90	112	54	14	16	M4 x 7	70	48	8	M8	12	43	47	4.8
BL 275	170	125	76	56	15	40	M5 x 8	85	56	10	M12	17.1	71.5	70	6.5
BL 475	170	125	152	56	15	40	M5 x 8	85	66	10	M12	17.1	71.5	70	13
BL 2115	243	170	125	80	15	70	M5 x 10	120	95	15	M14	22	99.8	93	21.6
BL 4115	243	170	250	80	15	70	M5 x 10	120	110	15	M14	22	99.8	93	43.2

1) Tolerance +/- 0.05 for all dimensions

Type	Dynamic load (N)	Limit loads (N)		Life coefficients	
	C _w ²⁾	Radial F _r ³⁾	Axial F _a ⁴⁾	X	Y
BL 252	59000	16800	8400	1	1
BL 452	118000	33600	16800	1	1
BL 275	99000	44200	22100	1	1
BL 475	198000	88400	44200	1	1
BL 2115	275000	78600	39300	1	1
BL 4115	550000	157200	78600	1	1

2) C_w basic load for 100 km, load perpendicular to the roller side fixing surface

3) Loads perpendicular to the roller side fixing surface

4) Loads parallel to the roller side fixing surface

- On request, the guide rollers can be supplied in stainless steel (suffix NX) and with Viton seals for operating temperatures up to 120°C (suffix V, not available for dimension BL ... 115). Internal rolling elements in standard bearing steel
- Pressure angle α for loads checking calculation: 45°
- Standard seals: material NBR, RS type

NEW

Carriages BL 2215 and BL 2280 can be supplied on request, for limit radial loads up to 540000 N.

CARRIAGES BL ... DS WITH DISCHARGE SYSTEM

42



Available in stainless steel version.

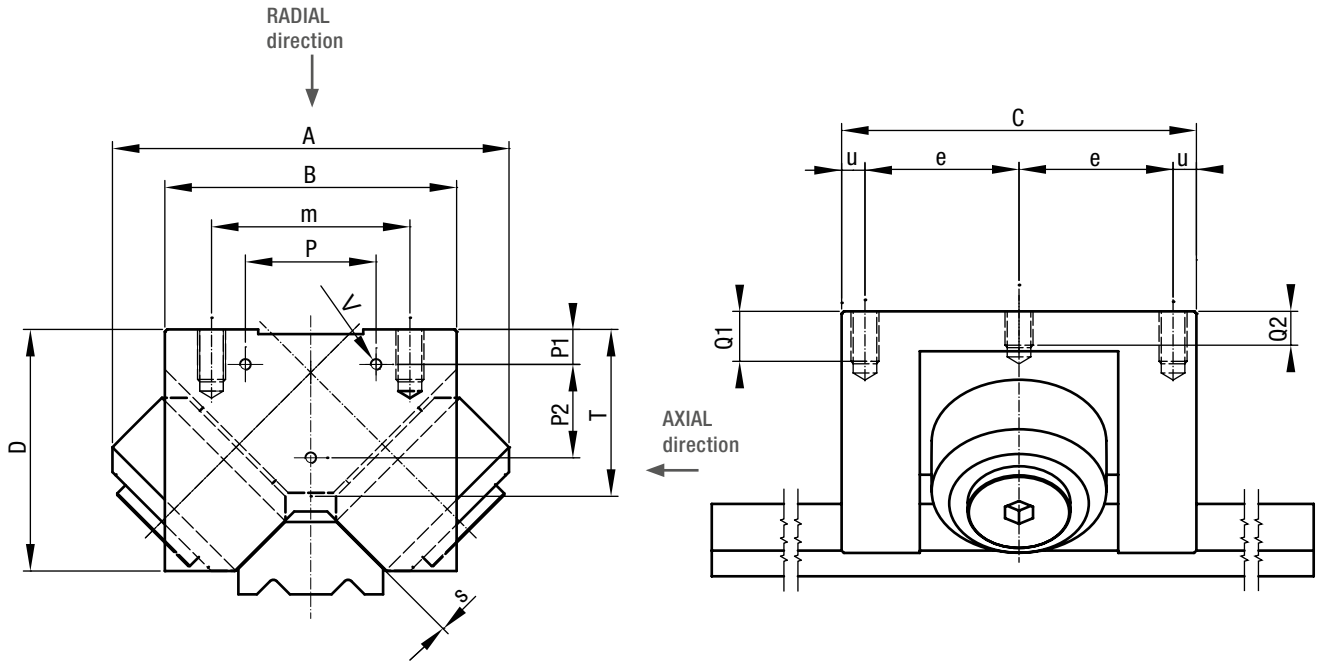

Type	Dimensions (mm)															Weight (kg)
	A	B	C	P	P1	P2	V	m	e	u	f	Q1	Q2	T		
BL 252 DS	136	90	112	54	14	16	M4 x 7	70	48	8	M8	16	12	43	4.8	
BL 275 DS	170	125	152	56	15	40	M5 x 8	85	66	10	M12	20	15	71.5	13	

Type	Dynamic load (N)	Limit loads (N)		Life coefficients	
	$C_w^{1)}$	Radial $F_r^{2)}$	Axial $F_a^{3)}$	X	Y
BL 252 DS	59000	16800	8400	1	1
BL 275 DS	99000	44200	22100	1	1

1) C_w basic load for 100 km, load perpendicular to the roller side fixing surface

2) Loads perpendicular to the roller side fixing surface

3) Loads parallel to the roller side fixing surface

- On request, the guide rollers can be supplied in stainless steel (suffix NX) and with Viton seals for operating temperatures up to 120°C (suffix V, not available for dimension BL ... 115). Internal rolling elements in standard bearing steel
- Pressure angle α (for loads checking calculation): 45°
- Standard seals: material NBR, RS type

ROLBLOC

ADJUSTMENT PLATES PR

Adjustment plates for BL carriages.

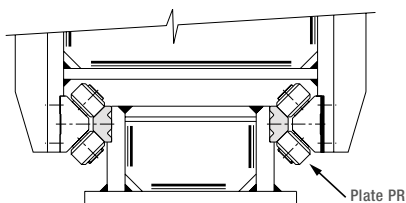
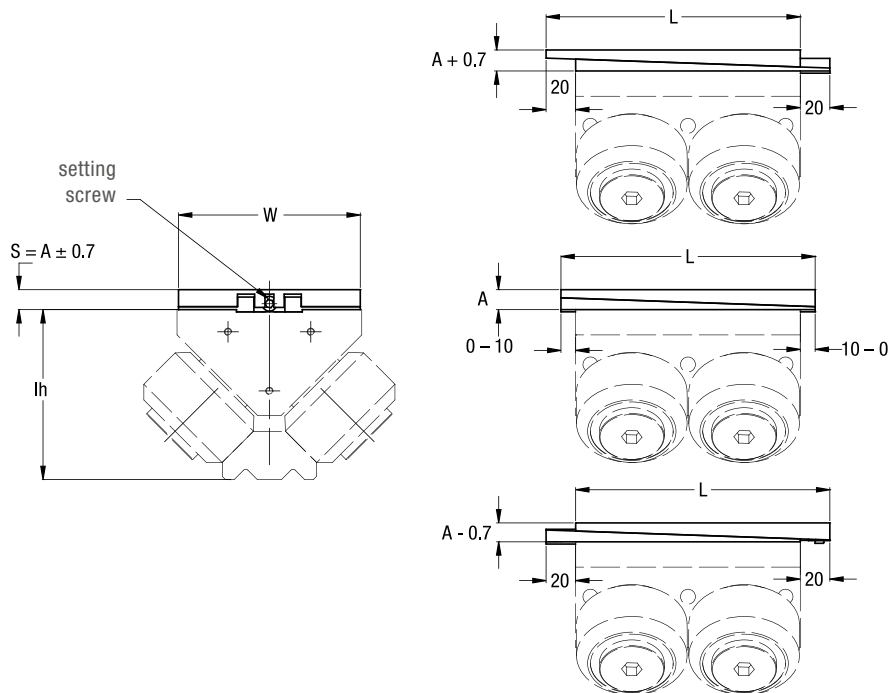
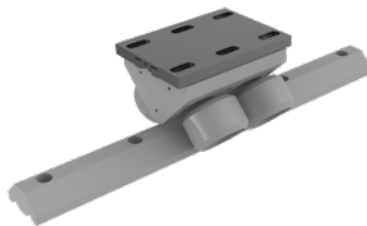

A typical example of Rolbloc system assembly, with opposing parallel guides is shown. For optimal assembly, it is recommended to use adjustment plates PR on one side

Type	Dimensions (mm)			Weight (kg)	Combination with ROLBLOC carriages
	L	W	A		
PR 252	76	88	13.5	0.5	BL 252
PR 452	132	88	13.5	1	BL 452, BL 252 DS
PR 275	96	123	13.5	1	BL 275
PR 475	172	123	13.5	1.9	BL 475, BL 275 DS
PR 2115	145	168	17	2.9	BL 2115
PR 4115	270	168	17	5.7	BL 4115

The adjusting plates allow to easily set the proper preload during the mounting on the machine by acting on the dimension lh.

The two steel plates are placed between the carriage Rolbloc and the mounting surface. Setting is done by the setting screw before the final tightening of the screws used to mount the Rolbloc.

Dimension W of the plates is 2 mm lower than Rolbloc central body.

Use the Rolbloc side as a reference for the positioning.

When the plates are set in the mid position (thickness A) they can be shifted 10 mm from the block centreline. The allowed displacement can be reduced with setting to zero for the minimum or maximum regulation. Consider 10 mm of space beyond the plate length on each side (20 mm over the block length) to use the full thickness setting capability +/- 0,7 mm.

WIPERS RPT

Material: Plastic (polyzene), color: green

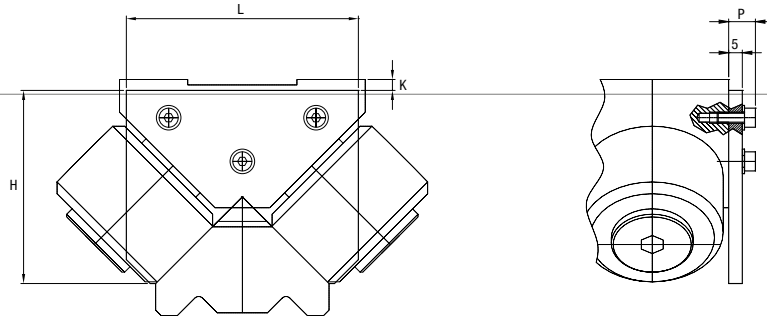

Type	Dimensions (mm)				Combination
	L	H	K	P	
RPT 52	85	70.75	4 ± 1.5	9.8	BL 252, BL 452
RPT 75	120	99.25	4 ± 2	11	BL 275, BL 475
RPT 115	165	135.55	5 ± 2	11	BL 2115, BL 4115

LUBL LUBRICATION SYSTEM FOR ROLBLOC

Material:
Plastic (polyzene), color: green and aluminum

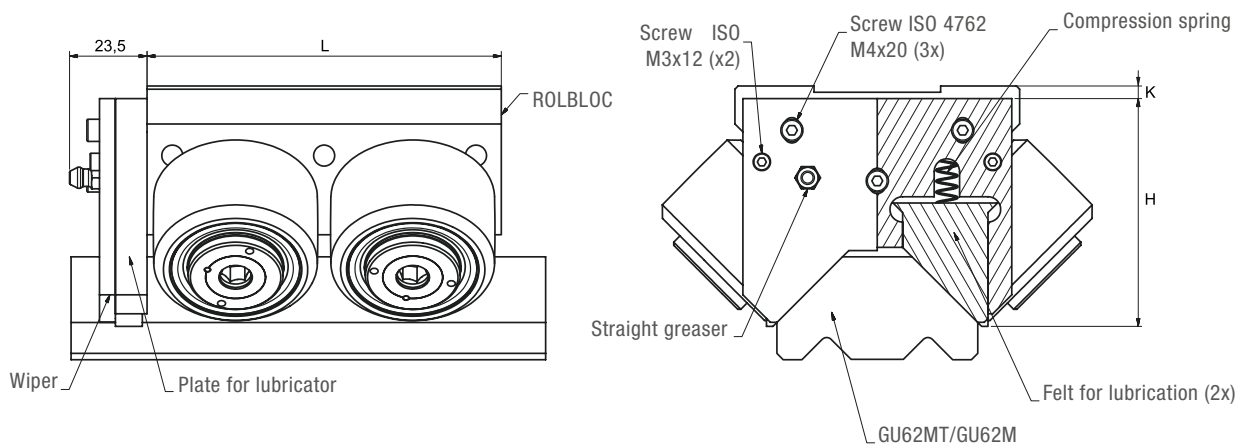

Type	Dimensions (mm)			Combination
	L	H	K	
LUBL 52	85	72	4 ± 1.5	BL 252, BL 452
LUBL 75	120	105.5	4 ± 1.5	BL 275, BL 475
LUBL 115	165	135.5	4 ± 1.5	BL 2115, BL 4115

ROLBLOC

GUIDE / CARRIAGE COMBINATIONS

4.3

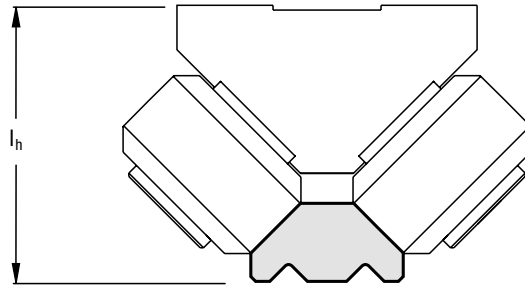

		Carriage					
		I_h (mm)					
Guide	Type	BL 252 / DS	BL 452	BL 275 / DS	BL 475	BL 2115	BL 4115
	GU 62 MT	86.5	86.5	115	115	–	–
	GU 62 M	85	85	113.5	113.5	–	–
	GU 80 MT	–	–	–	–	156.5	156.5
	GU 80 M	–	–	–	–	155	155

MOUNTING EXAMPLE

Palletising equipment
Robloc
V-Line
Multi-Motion-Line

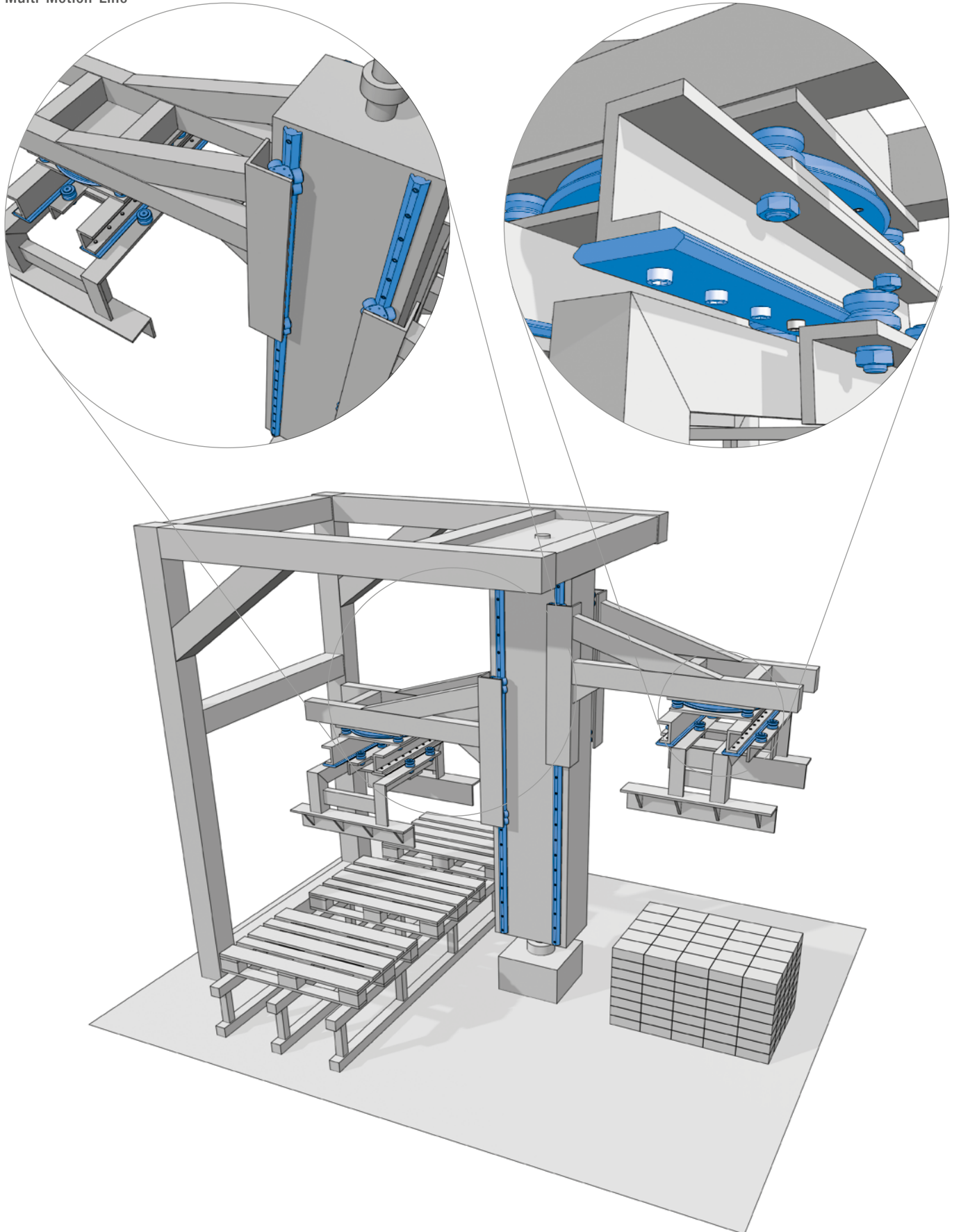

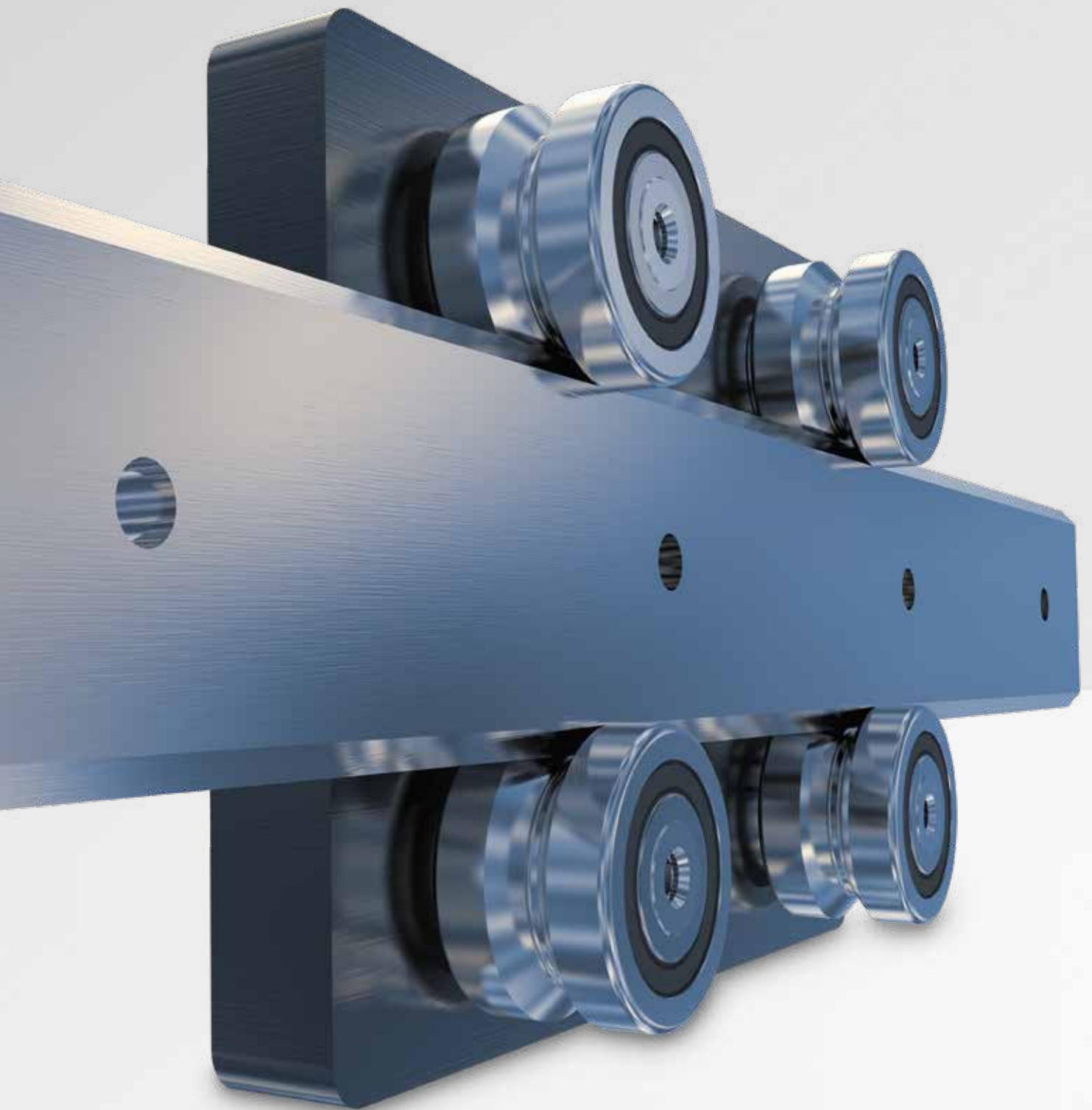

V-LINE

5

PAGE 48

5.1 SISTEMI V-LINE / FS

For medium-heavy loads

- Guide rails FS ... MT
- Guide rails FS ... M
- Guide rails FSH ... MT, FSX ... MT
- Guide rails FSH ... M, FSX ... M
- Guide rails FSHZ - FSXZ
- Guide rollers FR ... EU
- Guide rollers FR ... EU AS, FR ... EU AZ
- Guide rollers FRN ... EI
- Guide rollers RKY ..., RKX ...
- Guide wheels FKY ..., FKX ...
- Floating guide rollers FRL ... EU
- Floating guide rollers RKXL, RKYL
- Spacers for FS e FSH
- Pinion PZ..
- Lubricator LUBZ..
- Lubricator LUBY for FS guide rollers up to size 40
- Lubricator LUBY, LUBX for FS guide rollers up to size 52 and higher

PAGE 66

5.2 GUIDE ROLLERS COMBINATION

PAGE 68

5.3 MOUNTING EXAMPLES

V-LINE – FS SYSTEM

GUIDE RAILS FS ... MT

Rail in steel with sandblasted raceways.

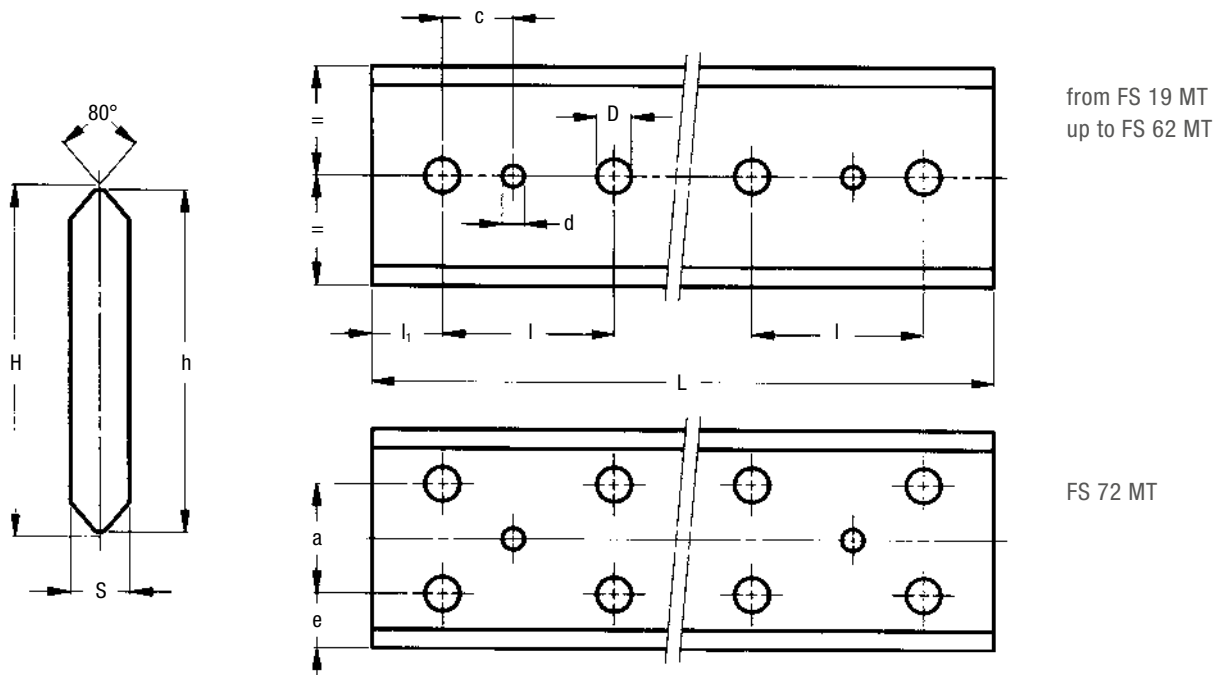

Type	Dimensions (mm)										Weight ²⁾ (kg/m)
	H ± 0.1	h ± 0.1	S ± 0.1	d ¹⁾ + 0.05	D	c ¹⁾	e	a	l	l ₁	
FS 19 MT	22.2	21	5.3	4	6.5	15	–	–	90	30	0.8
FS 22 MT	28.8	27	5.8	5	6.5	15	–	–	90	30	1.1
FS 32 MT	43.8	42	6.8	6	6.5	15	–	–	90	30	2.1
FS 35 MT	48.8	47	8.8	6	9	20	–	–	90	30	3.0
FS 40 MT	64.5	62	8.8	6	9	20	–	–	90	30	4.1
FS 47 MT	80.15	77.2	11	6	11.5	20	–	–	90	30	6.3
FS 52 MT	91.35	88.2	13	8	13.5	20	–	–	90	30	8.5
FS 62 MT	106	103	15.7	8	13.5	20	–	–	90	30	11.7
FS 72 MT	124.6	121	19	10	17.5	30	30.5	60	90	30	16.9

Max. length in single element L = 6000 mm.

Longer rails are made by juxtaposing several elements with ground end.

1) Standard layout without pin holes (pin holes only on request)

2) Weight without holes

RAILS FINISHING

- Drawn, induction hardened and sandblasted tracks (MT)
- Induction hardening on raceways only

HOLE LAYOUT

- Holes according to catalogue (SB)
- Finishes to drawing (NZ)
- Without holes (NF)

OPTIONAL FEATURES

- Ground one end: side of the first hole (1R), side of the last hole (2R)
- Ground both ends (RR)
- Chemical nickel-plating (NW)
- Pin holes¹⁾ (DP).

Example of standard designation: FS 52 MT 5280 SB

GUIDE FS ... M

Rail in steel with ground raceways.

Available in stainless steel version.

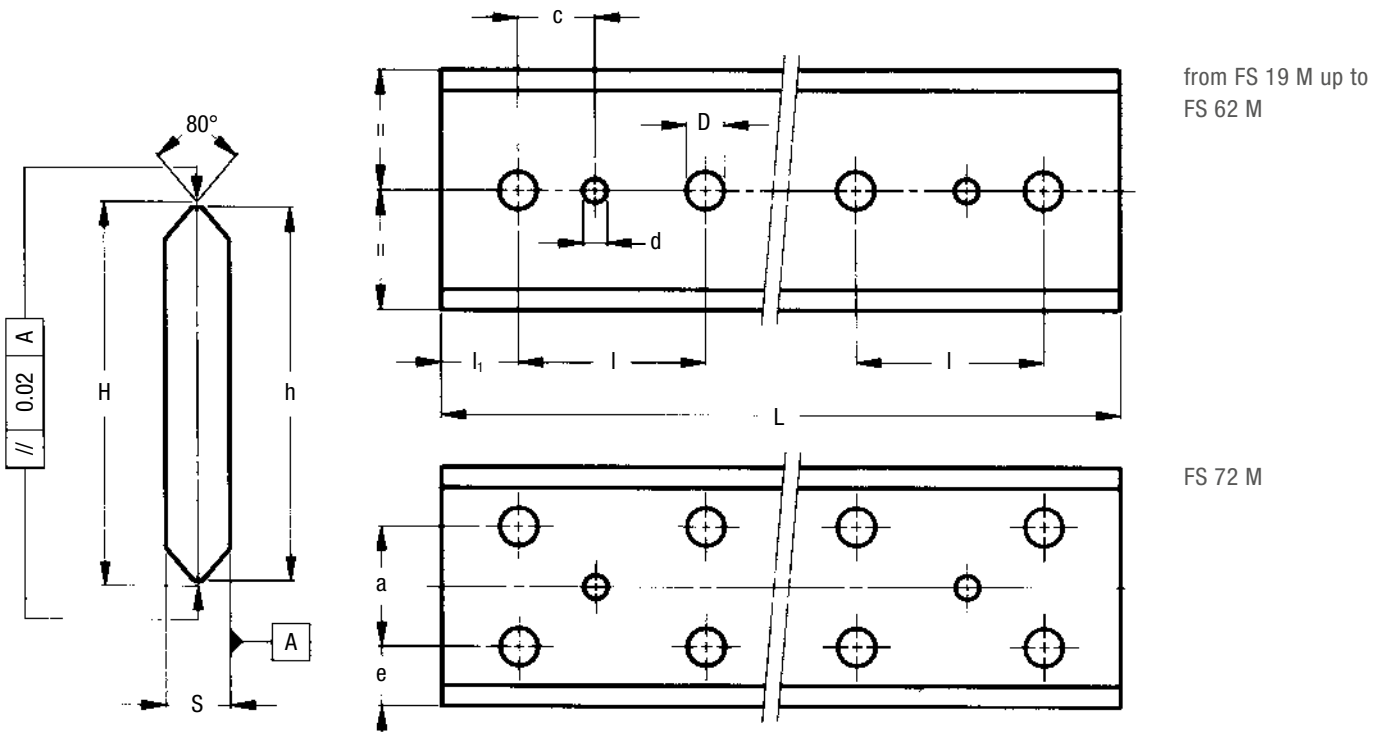

Type	Dimensions (mm)										Weight ³⁾ (kg/m)
	H ± 0.05	h ± 0.1	S ± 0.05	d ²⁾ + 0.05	D	c ²⁾	e	a	l	l ₁	
FS 19 M	20.95	20	4.5	4	6.5	15	–	–	90	30	0.6
FS 22 M ¹⁾	27.86	26	5	5	6.5	15	–	–	90	30	0.9
FS 32 M	42.86	41	6	6	6.5	15	–	–	90	30	1.8
FS 35 M ¹⁾	47.86	46	8	6	9	20	–	–	90	30	2.6
FS 40 M	63.58	61	8	6	9	20	–	–	90	30	3.7
FS 47 M ¹⁾	78.58	76	10	6	11.5	20	–	–	90	30	5.6
FS 52 M	89.78	87	12	8	13.5	20	–	–	90	30	7.7
FS 62 M	104.76	102	15	8	13.5	20	–	–	90	30	11.2
FS 72 M	122.98	120	18	10	17.5	30	30	60	90	30	15.8

Max. length in single element L = 4020 mm.

Longer rails are made by juxtaposing several elements with ground end.

1) Size 22, 35 e 47 available in stainless steel (NX)

2) Standard layout without pin holes (pin holes only on request)

3) Weight without holes

RAILS FINISHING

- Drawn, induction hardened and ground profile (M)
- Induction hardening on raceways only

HOLE LAYOUT

- Holes according to catalogue (SB)
- Finishes to drawing (NZ)
- Without holes (NF)

OPTIONAL FEATURES

- Stainless steel (NX) ¹⁾
- Ground one end: side of the first hole (1R), side of the last hole (2R)
- Ground both ends (RR)
- Chemical nickel-plating (NW)
- Pin holes ²⁾ (DP).

Example of standard designation: FS 40 M 2760 SB

V-LINE – FS SYSTEM

GUIDE RAILS FSH ... MT, FSX ... MT

Rail in steel with sandblasted raceways.

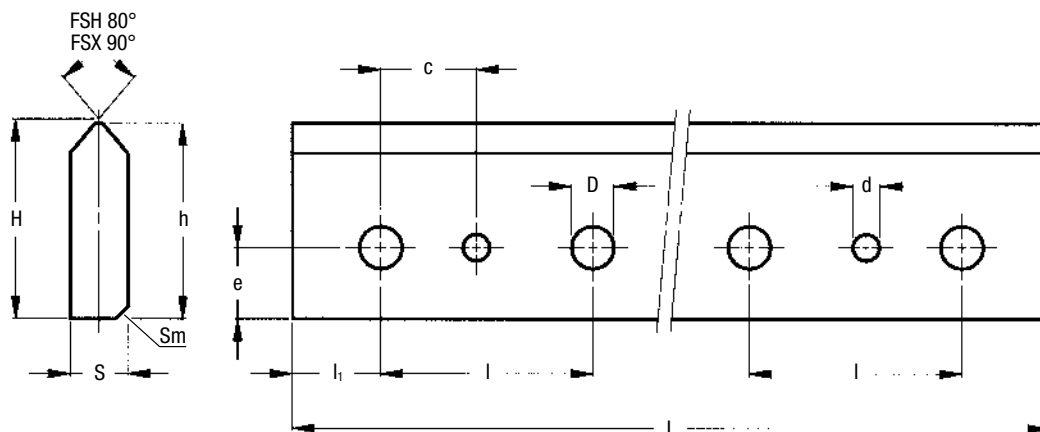

Type	Dimensions (mm)										Weight ²⁾ (kg/m)
	H ± 0.1	h ± 0.1	S ± 0.1	Sm	d ¹⁾ + 0.05	D	c ¹⁾	e	l	l ₁	
FSH 22 MT	23.9	23	5.8	0.9 x 45°	5	6.5	15	9	90	30	1.0
FSH 32 MT	29.9	29	6.8	1.4 x 45°	6	6.5	15	11	90	30	1.5
FSH 40 MT	37.2	36	8.8	1.4 x 45°	6	9	20	16	90	30	2.4
FSH 52 MT	40.75	39.2	13	2 x 45°	8	13.5	20	17	90	30	3.7
FSH 62 MT	50.75	49.2	16	2 x 45°	8	13.5	20	17	90	30	5.7
FSH 72 MT	60.85	59.2	19	2 x 45°	10	17.5	30	20	90	30	8.2
FSX 90 MT	62.85	61	26.5	1.5 x 45°	10	13.5	30	22	90	30	11.6

Max. length in single element L = 6000 mm.

Longer rails are made by juxtaposing several elements with ground end.

1) Standard layout without pin holes (pin holes only on request)

2) Weight without holes

RAILS FINISHING

- Drawn, induction hardened and sandblasted tracks (MT)
- Induction hardening on raceways and base only

HOLE LAYOUT

- Holes according to catalogue (SB)
- Finishes to drawing (NZ)
- Without holes (NF)

OPTIONAL FEATURES

- Ground one end: side of the first hole (1R), side of the last hole (2R)
- Ground both ends (RR)
- Chemical nickel-plating (NW)
- Pin holes¹⁾ (DP).

Example of standard designation: FSH 52 MT 5280 SB

GUIDE FSH ... M, FSX ... M

Rail in steel with ground raceways.

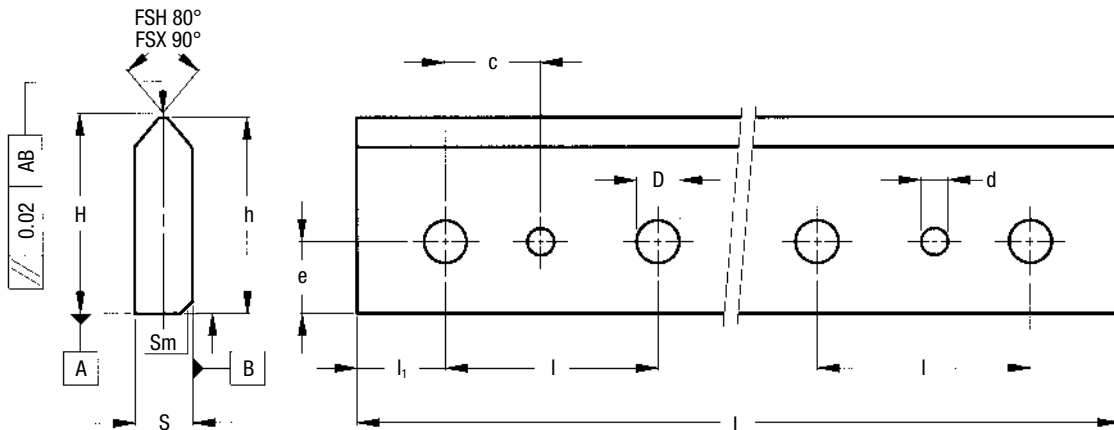

Type	Dimensions (mm)										Weight ²⁾ (kg/m)
	H ± 0.05	h ± 0.1	S ± 0.05	Sm	d ¹⁾ + 0.05	D	c ¹⁾	e	l	l ₁	
FSH 19 M	18.98	18.5	4.5	0.5 x 45°	4	6.5	15	8	90	30	0.6
FSH 22 M	22.93	22	5	0.2 x 45°	5	6.5	15	9	90	30	0.8
FSH 32 M	28.93	28	6	0.5 x 45°	6	6.5	15	11	90	30	1.2
FSH 40 M	36.29	35	8	0.5 x 45°	6	9	20	16	90	30	2.1
FSH 52 M	39.39	38	12	1 x 45°	8	13.5	20	17	90	30	3.4
FSH 62 M	49.38	48	15	1 x 45°	8	13.5	20	17	90	30	5.2
FSH 72 M	59.49	58	18	1 x 45°	10	17.5	30	20	90	30	7.6
FSX 90 M	61.79	60	26	0.5 x 45°	10	13.5	30	22	90	30	11

Max. length in single element L = 4020 mm.

Longer rails are made by juxtaposing several elements with ground end.

1) Standard layout without pin holes (pin holes only on request)

2) Weight without holes

RAILS FINISHING

- Drawn, induction hardened and ground profile (M)
- Induction hardening on raceways and base only

HOLE LAYOUT

- Holes according to catalogue (SB)
- Finishes to drawing (NZ)
- Without holes (NF)

OPTIONAL FEATURES

- Ground one end: side of the first hole (1R), side of the last hole (2R)
- Ground both ends (RR)
- Chemical nickel-plating (NW)
- Pin holes¹⁾ (DP).

Example of standard designation: FSH 40 M 2760 SB

GUIDE FSHZ FSXZ

Steel guides with integrated rack

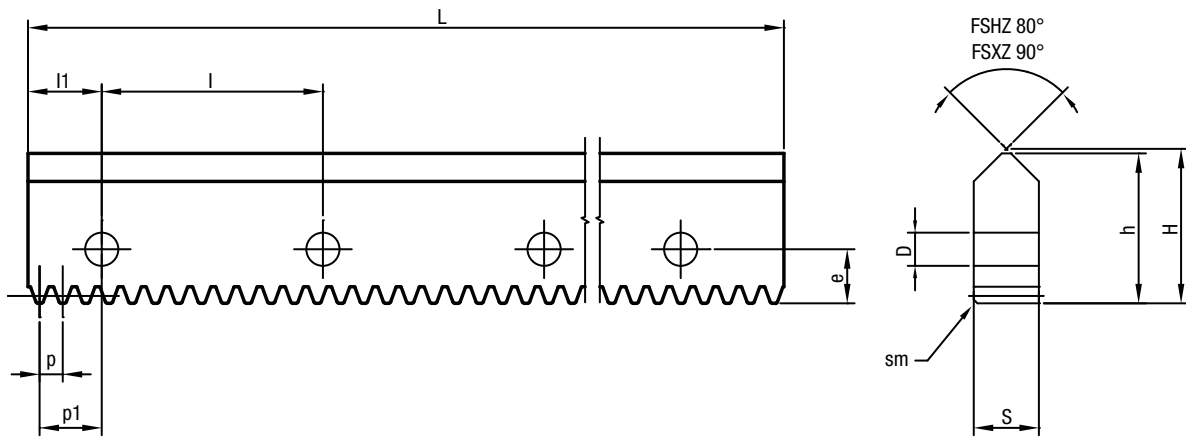

Type	H	h	S	Sm x 45°	Module	Step p	D	e	l	l1	p1	Push ²⁾ (N)	Weight ¹⁾ (kg/m)
FSHZ 52 MT	40.75	39.2	13	2	m 1.5	4.712	13.5	17	90	30	27.64	1100	3.6
FSHZ 72 MT	60.85	59.2	19	2	m 2	6.283	17.5	20	90	30	26.86	2100	8
FSXZ 90 MT	62.85	61	26.5	1.5	m 3	9.425	13.5	22	90	30	25.29	4400	11

Maximum length of single element L = 3000 mm.

Longer rails are made by juxtaposing several elements with ground end.

1) Weight without holes

2) Calculated thrust with lubricated rack coupled with a Z20 pinion to achieve a long service life.

Apply a safety factor according to the type of application.

FINISHING ..MT

- Drawn induction hardened on raceway and sand blaster
- Standard rack type: straight, cut and hardened Quality 10

ON REQUEST

- Ground rail ..M
- Induction hardened and ground rack
- Angle rack - special rack on request

HOLE LAYOUT:

- Holes accordingly to catalogue (SB)
- Finished to drawing (NZ)
- Without holes (NF)

Example of standard designation: FSXZ90MT 2300 SB

V-LINE / FS SYSTEM

GUIDE ROLLERS FR ... EU

Guide roller with ball bearings.
The sides of the race are slightly convex.



Available in stainless steel version.



CONCENTRIC

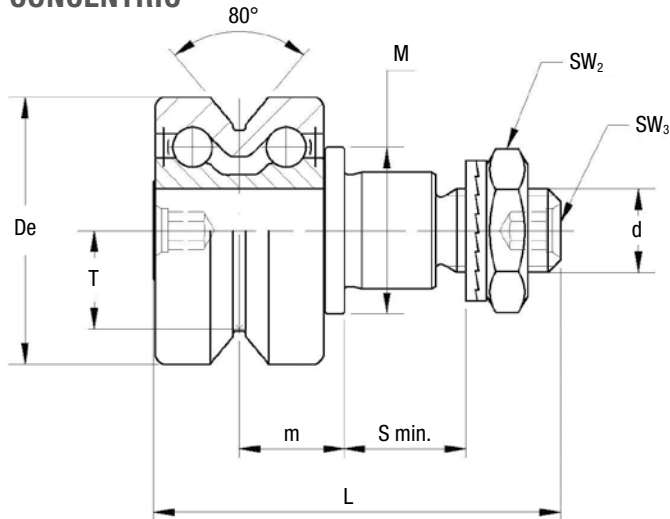

ECCENTRIC

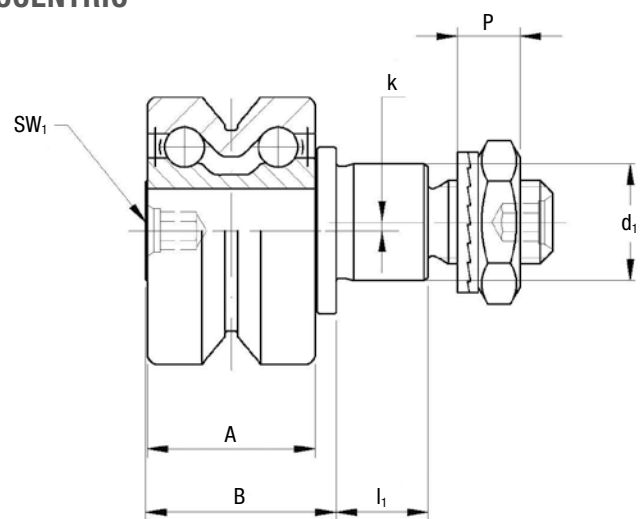

Type		Dimensions (mm)															
concentric	eccentric	De	d ₁ ²⁾	d	T	m	S _{min.}	P	L	A	B	I ₁	M	SW ₁	SW ₂	SW ₃	k
FR 22 EU ^{1) 3)}	FRR 22 EU ^{1) 3)}	22	9	M6 x 1	7.7	9.4	9	6.5	36.8	15	18	8	14	4	10	2,5	0.5
FR 32 EU ¹⁾	FRR 32 EU ¹⁾	32	14	M10 x 1.25	11.8	12.6	12	8.5	48.9	20.2	22.9	11	20	4	17	4	1
FR 40 EU ¹⁾	FRR 40 EU ¹⁾	40	16	M12 x 1.5	14.6	15.5	12	10.4	58.5	25	29.5	11	22	5	19	5	1
FR 52 EU	FRR 52 EU	52	21	M16 x 1.5	19.1	19.8	15	11.4	69.5	32	36.5	14	28	6	24	6	1.5
FR 62 EU	FRR 62 EU	62	27	M20 x 1.5	22.1	20.8	18.5	12.4	80	33.6	39	17.5	35	8	30	8	2

1) FR/R 22, 32, 40 are available in stainless steel (NX)

2) Housing bore tolerance: H7

3) FR/R 22 EUNX: VAC for high vacuum applications on request

Type		Dynamic load (N)	Limit loads (N)		Life coefficients		Torque wrench settings ⁵⁾ (Nm)	Weight (g)
		C _w ⁴⁾	Radial F _r	Axial F _a	X	Y		
FR 22 EU	FRR 22 EU	2900	1400	420	1	2	5	45
FR 32 EU	FRR 32 EU	5800	2000	800	1	1.9	20	125
FR 40 EU	FRR 40 EU	8500	3650	1400	1	1.9	26	230
FR 52 EU	FRR 52 EU	11700	8500	3000	1	1.9	64	510
FR 62 EU	FRR 62 EU	13900	11000	3500	1	1.9	120	765

4) C_w basic load for 100 km

5) The torque wrench settings are given for non-lubricated threads; for lubricated threads, multiply figure by 0.8

- The guide rollers are complete with self-locking washers and hexagonal nut (DIN 439B) for fitting
- Standard: NBR seals RS type
- Pressure angle α for load calculation: 40°

GUIDE ROLLERS FR ... EU AS, FR ... EU AZ

Guide rollers with ball bearings.

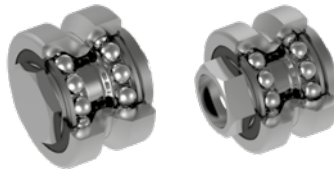

Available in stainless steel version.

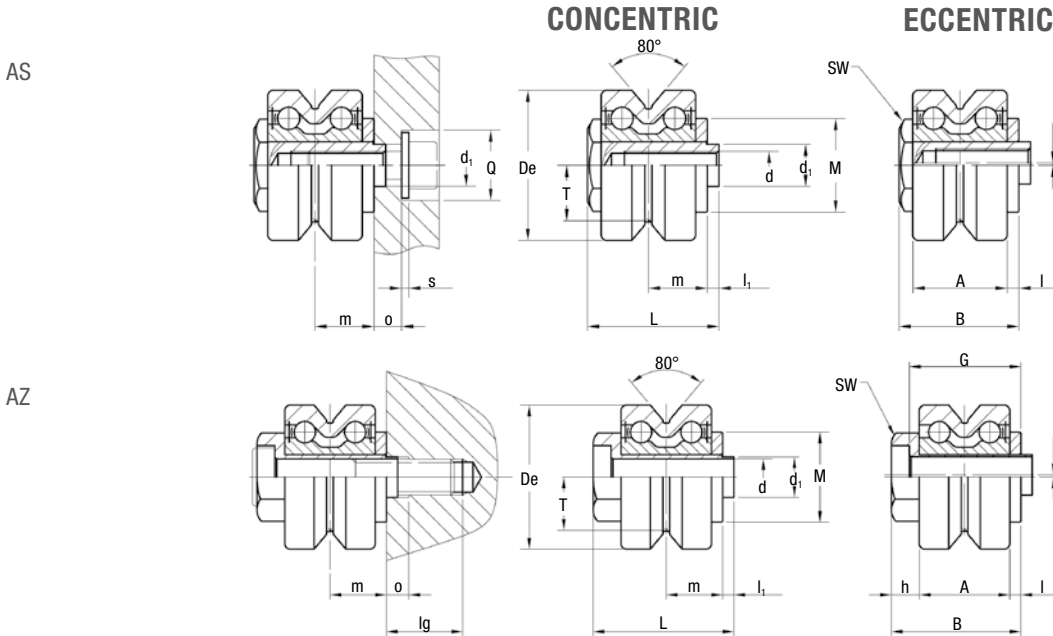

Type	Dimensions (mm)																			
concentric	eccentric	De	d ₁ ²⁾	d ³⁾	T	m	L	A	B	I ₁	I	h	M	SW	G	o	Q	Ig ⁴⁾	s	k
FR 22 EU AS ¹⁾ 7)	FRR 22 EU AS ¹⁾ 7)	22	6	M 5	7.7	9.4	21.8	15	19.8	2	1.9	-	14	10	-	4.5	10	-	0	0.5
FR 32 EU AS ¹⁾	FRR 32 EU AS ¹⁾	32	9	M 6	11.8	12.6	28.1	20.2	25.6	2.5	2.5	-	20	17	-	6	15	-	1.5 ⁵⁾	0.5
FR 40 EU AS ¹⁾	FRR 40 EU AS ¹⁾	40	11	M 8	14.6	15.5	33.5	25	31	2.5	3	-	22	22	-	6.5	20	-	2 ⁵⁾	1
FR 52 EU AS	FRR 52 EU AS	52	16	M10	19.1	19.8	43.2	32	40	3.2	3.8	-	28	27	-	8	24	-	2.5 ⁵⁾	1.5
FR 62 EU AS	FRR 62 EU AS	62	19	M12	22.1	20.8	46	33.6	41.8	4.2	4	-	35	30	-	9	26	-	2.5 ⁶⁾	1.5
FR 22 EU AZ ¹⁾	FRR 22 EU AZ ¹⁾	22	6	5.1	7.7	9.4	23.9	15	21.9	2	1.9	5	14	11	18.9	4	-	13	-	0.5
FR 32 EU AZ ¹⁾	FRR 32 EU AZ ¹⁾	32	9	8.1	11.8	12.6	31.4	20.2	28.9	2.5	2.5	6.2	20	17	24.9	5	-	17	-	0.5
FR 40 EU AZ ¹⁾	FRR 40 EU AZ ¹⁾	40	11	10.1	14.6	15.5	38	25	35.5	2.5	3	7.5	22	22	30.5	5	-	26	-	0.8
FR 52 EU AZ	FRR 52 EU AZ	52	16	14.1	19.1	19.8	49.5	32	46.3	3.2	3.8	10.5	28	27	39.3	5.5	-	27	-	1.5
FR 62 EU AZ	FRR 62 EU AZ	62	19	16.1	22.1	20.8	54.5	33.6	50.3	4.2	4	12.7	35	32	42.3	6.5	-	30	-	1.5

1) FR / R 22, 32, 40 AS and AZ are available in stainless steel (NX)

2) Housing bore tolerance: H7

3) Safety threads SPIRALOCK

4) AZ: minimum length of the thread engaged

steel = 1 x d; cast iron = 1.25 x d; aluminium = 2 x d

AS: screws length: min. = d + o + s; max. = m + 4 + o + s

5) Guide roller with washers DIN 134 without screw DIN 7984 or DIN 912

6) Guide roller with washers DIN 125 without screw DIN 7984 or DIN 912

7) FR/R 22 EUNX: VAC for high vacuum applications on request

Guide roller size	Dynamic load (N)	Limit loads (N)		Life coefficients		Weight AS (g)	Weight AZ (g)	On request for AZ screw DIN 7984
	C _w ⁸⁾	Radial F _r	Axial F _a	X	Y			
22	2900	470	210	1	2	33	31	M5 x 30
32	5800	1590	710	1	1.9	95	93	M8 x 40
40	8500	2120	940	1	1.9	173	173	M10 x 50
52	11700	5830	2560	1	1.9	374	365	M14 x 60
62	13900	9200	3500	1	1.9	582	587	M16 x 65

8) C_w basic load for 100 km

- NBR seals RS type
- Pressure angle α for load calculation: 40°

V-LINE / FS SYSTEM

GUIDE ROLLERS FRN ... EI

Guide roller with needle roller bearings.
The sides of the race are slightly convex.



Available in stainless steel version.



CONCENTRIC

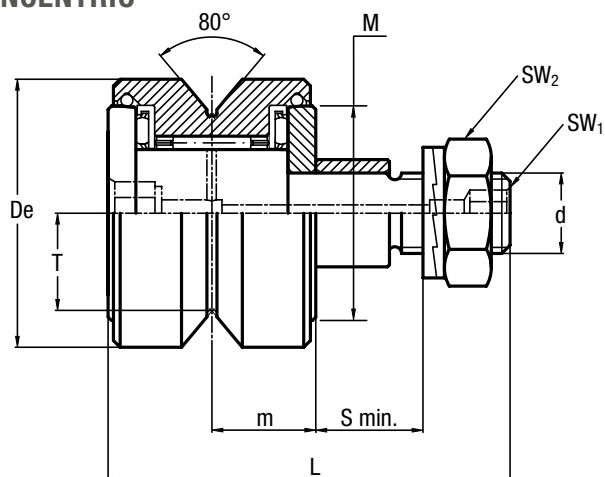

ECCENTRIC

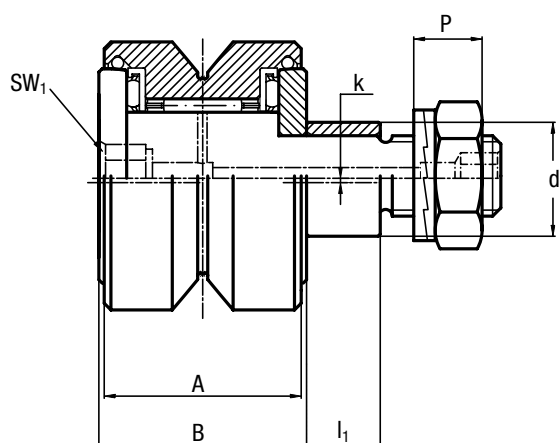

Type		Dimensions (mm)														
concentric	eccentric	De	d ₁ ²⁾	d	T	m	S min.	P	L	A	B	I ₁	M	SW ₁	SW ₂	k
FRN 19 EI ¹⁾	FRNR 19 EI ¹⁾	19	7	M5 x 0.8	7	8.8	6.5	4.2	34	17	18	5.5	14	³⁾	8	0.5
FRN 22 EI ¹⁾	FRNR 22 EI ¹⁾	22	9	M6 x 1	7.7	9.4	9	6.5	39	18.2	20	8	16.5	³⁾	10	0.5
FRN 32 EI ¹⁾	FRNR 32 EI ¹⁾	32	14	M10 x 1.25	11.8	12.6	12	10.4	52	24.2	26	11	25	4	16	1
FRN 40 EI ³⁾	FRNR 40 EI ³⁾	40	16	M12 x 1.5	14.6	15.5	12	11.4	60	29.4	31	11	32	8	19	1

1) Lubrication hole only on head side

2) Housing bore tolerance: H7. Lubrication hole also on stud side

3) Relubrication hole at the roller and stud side

For size 19 and 22: screw driver slot on the head and hexagonal socket at the threaded end of the stud

Type		Dynamic load (N)		Limit loads (N)		Torque wrench settings ⁵⁾ (Nm)	Weight (g)
		C _{wr} ⁴⁾	C _{wa} ⁴⁾	Radial F _r	Axial F _a		
FRN 19 EI	FRNR 19 EI	1800	600	490	270	1.8	35
FRN 22 EI	FRNR 22 EI	3280	800	590	290	3	53
FRN 32 EI	FRNR 32 EI	5600	2100	2030	950	20	160
FRN 40 EI	FRNR 40 EI	12300	2600	2800	1350	26	290

4) C_w basic load for 100 km

5) The torque wrench settings are given for non-lubricated threads; for lubricated threads, multiply figure by 0.8

- On request, the guide rollers can be supplied with external parts in stainless steel (suffix NX). Internal rolling elements in standard bearing steel
- The guide rollers are complete with self-locking washers and hexagonal nut (DIN 439B) for fitting

- Pressure angle α for load calculation: 40°
- Standard Viton seals to fit temperature up to 120°C

GUIDE ROLLERS RKY ..., RKX ...

Guide rollers with tapered roller bearings.
The sides of the race are convex with radius $R = 400$.

Available in stainless steel version.



CONCENTRIC

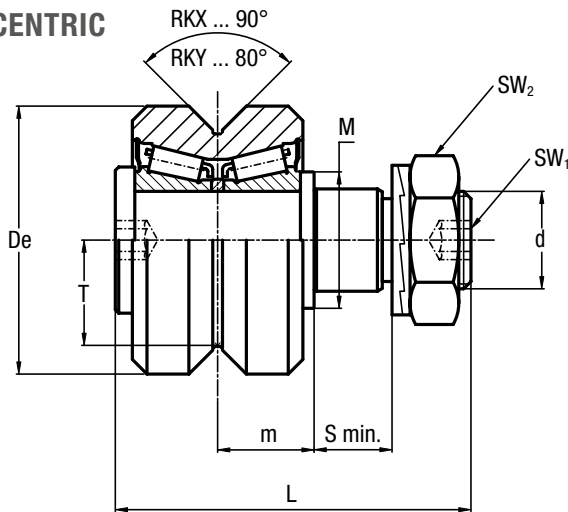

ECCENTRIC

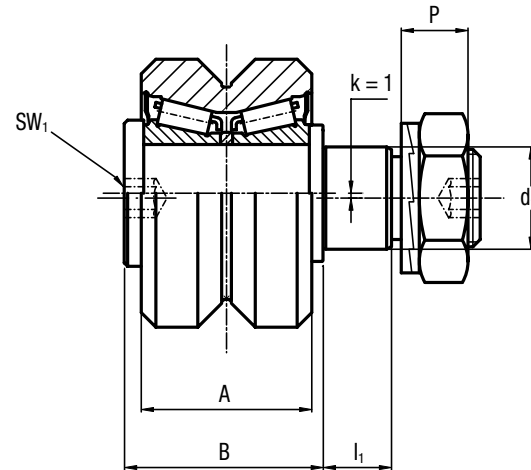

Type		Dimensions (mm)														
concentric	eccentric	De	d ₁ ¹⁾	d	T	m	S min.	P	L	A	B	I ₁	M	SW ₁	SW ₂	k
RKY 52	RKYR 52	52	21	M20 x 1.5	19.1	19.8	15	13.4	73	35	41	14	28	8	30	1
RKY 62	RKYR 62	62	27	M24 x 1.5	22.1	20.8	19	15.4	83	37	44	18	35	10	36	1
RKY 72	RKYR 72	72	36	M30 x 1.5	25.5	27	19	21.6	100	45	55	18	44	12	46	1
RKX 90 C	RKXR 90 C	90	38	M36 x 1.5	32.5	30	24	24.6	115	53 56 ²⁾	62	23	50	14	55	1
RKX 110 C	RKXR 110 C	110	42	M36 x 1.5	39.5	34	33	24.6	135	60 63 ²⁾	70	32	56	14	55	1

1) Housing bore tolerance: H7

2) Dimensions relating to the stainless-steel rollers (suffix NX)

Type		Dynamic load (N)	Limit loads (N)		Life coefficients		Torque wrench settings ⁴⁾ (Nm)	Weight (kg)
		C _w ³⁾	Radial F _r	Axial F _r	X	Y		
RKY 52	RKYR 52	41000	11900	4800	1	3.7	80	0.6
RKY 62	RKYR 62	46000	19000	8300	1	3.5	160	0.9
RKY 72	RKYR 72	66000	30000	12300	1	3.2	300	1.6
RKX 90 C	RKXR 90 C	130000	41000	15300	1	3.8	450	2.8
RKX 110 C	RKXR 110 C	185000	55000	20900	1	3.9	450	4.9

3) C_w basic load for 100 km

4) The torque wrench settings are given for non-lubricated threads; for lubricated threads, multiply figure by 0.8

- Standard seals: material NBR, RS type
- On request, the guide rollers can be supplied with external parts in stainless steel (suffix NX) and with Viton seals for operating temperatures up to 120°C (suffix V), not available for dimension RKX (R) 110 C. Internal rolling elements in standard bearing steel
- The guide rollers are complete with self-locking washers and hexagonal nut (DIN 439B) for fitting
- Pressure angle α for load calculation: guide rollers RKY 40° – guide rollers RKX 45°

V-LINE / FS SYSTEM

GUIDE WHEELS FKX ..., FKX ...

Guide wheel with tapered roller bearings.
The sides of the race are convex.



Available in stainless steel version.

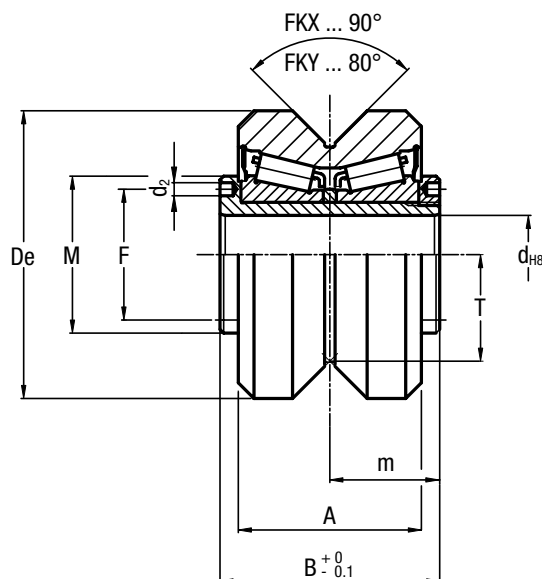

Type	Dimensions (mm)									Weight (kg)
	De	d	T	m	A	B	F	d ₂	M	
FKY 52 C	52	15	19.1	21	35	42	25	2.5	30	0.5
FKY 62 C	62	20	22.1	22.5	37	45	29	3	35	0.6
FKY 72 C	72	25	25.5	28	45	56	37	4	44	1.2
FKX 90 C	90	28	32.5	32	53 56 ¹⁾	64	42	4	49	2.3
FKX 110 C	110	35	39.5	36	60 63 ¹⁾	72	52	4	59	3.9

¹⁾ Dimensions relating to the stainless-steel rollers (suffix NX)

Type	Dynamic load (N)	Limit loads (N)		Life coefficients	
	C _w ²⁾	Radial F _r	Axial F _a	X	Y
FKY 52 C	41000	11900	4800	1	3.7
FKY 62 C	46000	19000	8300	1	3.5
FKY 72 C	66000	30000	12300	1	3.2
FKX 90 C	130000	41000	15300	1	3.8
FKX 110 C	185000	55000	20900	1	3.9

²⁾ C_w basic load for 100 km

- On request, the guide rollers can be supplied with external parts in stainless steel (suffix NX) and with Viton seals for operating temperatures up to 120°C (suffix V), not available for dimension FKX 110 C. Internal rolling elements in standard bearing steel
- To prevent rotation between roller and shaft a pin can be fitted in one of the holes "d2" positioned in the side flange
- Pressure angle α for load calculation: guide rollers FKY 40° – guide rollers FKX 45°
- Standard seals: material NBR, RS type

FLOATING GUIDE ROLLERS FRL ... EU

Floating guide rollers with ball bearings.
The race ways are slightly convex.

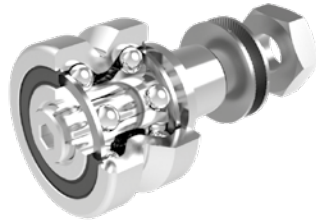

Available in stainless steel version.



CONCENTRIC

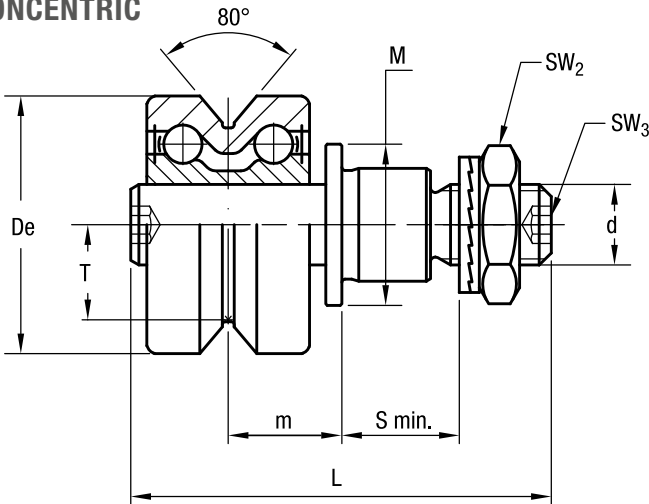

ECCENTRIC

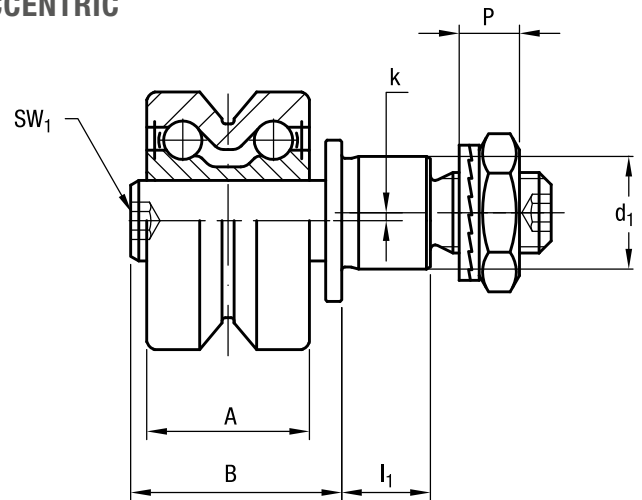

Type		Dimensions (mm)																
concentric	eccentric	De	d ₁ ²⁾	d	T	S min.	P	L	A	B	I ₁	M	m min. ³⁾	m max. ³⁾	SW ₁	SW ₂	SW ₃	k
FRL 22 EU ¹⁾	FRLR 22 EU ¹⁾	22	9	M6 x 1.0	7.7	9	6.5	39.3	15	20.5	8	14	9	13	4	10	3	0.8
FRL 32 EU ¹⁾	FRLR 32 EU ¹⁾	32	14	M10 x 1.25	11.8	12	8.5	52.2	20.2	26.2	11	20	12.1	16.1	4	17	4	1
FRL 40 EU ¹⁾	FRLR 40 EU ¹⁾	40	16	M12 x 1.5	14.6	12	10.4	61.4	25	32.4	11	22	14.9	19.9	5	19	5	1
FRL 52 EU	FRLR 52 EU	52	21	M16 x 1.5	19.1	15	11.4	74	32	41	14	28	19	25	6	24	6	1.5
FRL 62 EU	FRLR 62 EU	62	27	M20 x 1.5	22.1	18.5	12.4	83.6	33.6	42.6	17.5	35	19.8	25.8	8	30	8	2

1) Available in stainless steel (NX) version

2) Housing bore tolerance: H7

3) To ensure a safe and proper functioning the dimension m must not be higher than m max.

Type		Dynamic load (N)	Limit loads (N)	Limit loads Inox version NX (N)	Torque wrench settings ⁵⁾ (Nm)	Weight ⁶⁾ (g)
		C _w ⁴⁾	Radial F _r	Radial F _r		
FRL 22 EU	FRLR 22 EU	2900	1050	900	3	46
FRL 32 EU	FRLR 32 EU	5800	1700	1500	20	127
FRL 40 EU	FRLR 40 EU	8500	3000	2700	26	233
FRL 52 EU	FRLR 52 EU	11700	7600	—	64	520
FRL 62 EU	FRLR 62 EU	13900	11000	—	120	776

4) C_w = Basic load for 100 km

5) The torque wrench settings are given for non-lubricated threads; for lubricated threads multiply figure by 0.8

6) Weight without fittings

- Standard seals: material NBR, RS type
- Guide rollers include self-locking washers and hexagonal nut (DIN 439B)

- Pressure angle α for load calculation: 40°.

V-LINE / FS SYSTEM

FLOATING GUIDE ROLLERS RKXL, RKYL

Floating guide rollers with tapered roller bearings for FS.

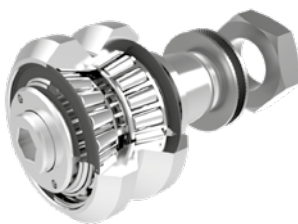

Available in stainless steel version.



CONCENTRIC

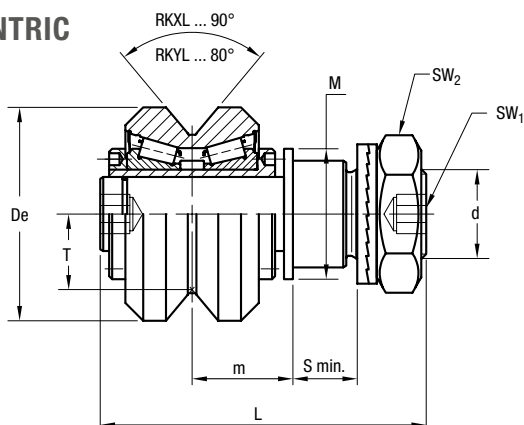

ECCENTRIC

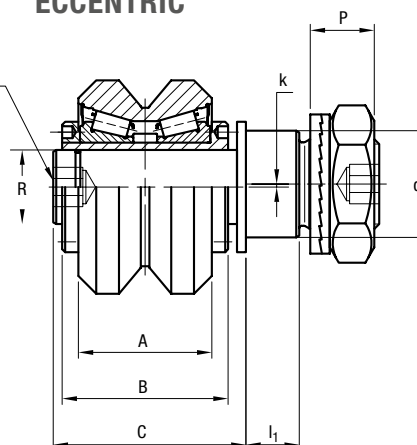

Type		Dimensions (mm)																	
concentric	eccentric	De	d ₁ ¹⁾	d	T	m	m	S	R	P	L	A	B	C	I ₁	M	SW ₁	SW ₂	k
						min. ²⁾	max. ²⁾	min.											
RKYL 52	RKYL R 52	52	21	M20 x 1.5	19.1	24	30	15	15	13.4	83	35	42	51	14	30	8	30	1
RKYL 62	RKYL R 62	62	27	M24 x 1.5	22.1	25.5	31.5	19	20	15.4	93	37	45	54	18	35	10	36	1
RKYL 72	RKYL R 72	72	36	M30 x 1.5	25.5	31	37	19	25	21.6	110	45	56	65	18	44	12	46	1
RKXL 90	RKXL R 90	90	38	M36 x 1.5	32.5	36	43	24	28	24.6	128	53 56 ³⁾	64	75	23	49	14	55	1
RKXL 110	RKXL R 110	110	42	M36 x 1.5	39.5	40	47	33	35	24.6	148	60 63 ³⁾	72	83	32	59	14	55	1

1) Housing bore tolerance: H7

2) To ensure a safe and proper functioning the dimension m must not be higher than m max.

3) Dimensions for stainless steel (NX) version

Type		Dynamic load (N)	Limit loads (N)	Torque wrench settings ⁵⁾ (Nm)	Weight (g)
		C _w ⁴⁾	Radial F _r		
RKYL 52	RKYL R 52	41000	3050	80	630
RKYL 62	RKYL R 62	46000	6850	160	950
RKYL 72	RKYL R 72	66000	11200	300	1680
RKXL 90	RKXL R 90	130000	13800	450	2900
RKXL 110	RKXL R 110	185000	24000	450	5000

4) C_w = Basic load for 100 km

5) The torque wrench settings are given for non-lubricated threads; for lubricated threads multiply figure by 0.8

- On request, the guide rollers can be supplied with viton seals for operating temperatures up to 120°C (suffix V), not available for RKXL 110
- Internal rolling elements in standard bearing steel
- Standard seals: material NBR, RS type
- Pressure angle α for load calculation: 40°

SPACERS FOR FS AND FSH

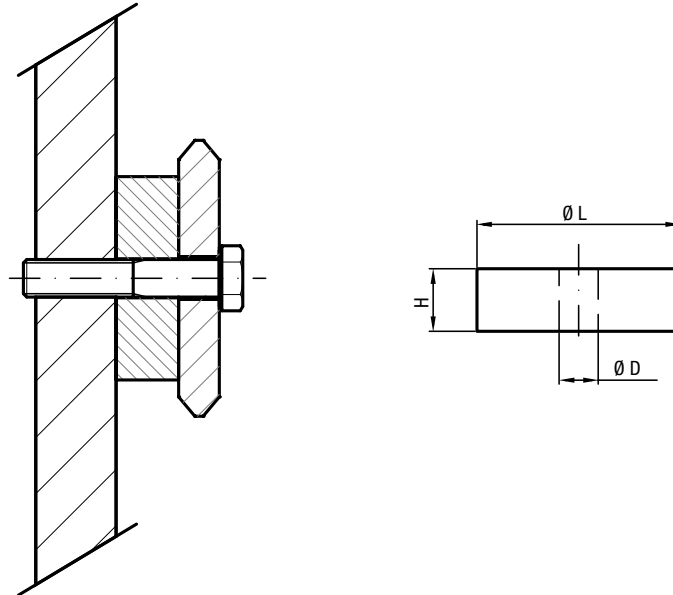
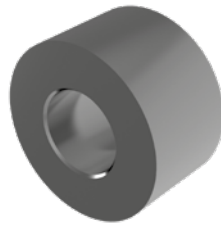

Type	Dimensions (mm)			Suggested combinations
	Ø L	Ø D	H	
DIST FS 19	12	6.5	10	FS 19, FSH 19
DIST FS 22	15	6.5	10	FS 22, FSH 22, FSR 22
DIST FS 32	30	6.5	15	FS 32
DIST FS 35	35	8.5	15	FS 35, FSR 35
DIST FS 40	50	8.5	15	FS 40
DIST FS 47	60	10.5	20	FS 47, FSR 47
DIST FS 52	65	12.5	20	FS 52
DIST FS 62	80	12.5	20	FS 62
DIST FS 72	35	16.5	20	FS 72, FSH 72
DIST FSH 32	20	6.5	15	FSH 32
DIST FSH 40	25	8.5	15	FSH 40
DIST FSH 52	25	12.5	20	FSH 52
DIST FSH 62	25	12.5	20	FSH 62
DIST FSX 90	43	12.5	30	FSX 90

- The spacers, mounted between the guide and the supporting structure, guarantee adequate distance for the sliding of the rollers
- The spacers DIST are designed for guides FS and FSH of V-Line and guides FSR of Multi-Motion-Line
- Delivery without screws

FINISHING

- Anodized aluminium

OPTIONAL FEATURES

- Steel

GUIDE FSHZ FSXZ

PINION PZ..

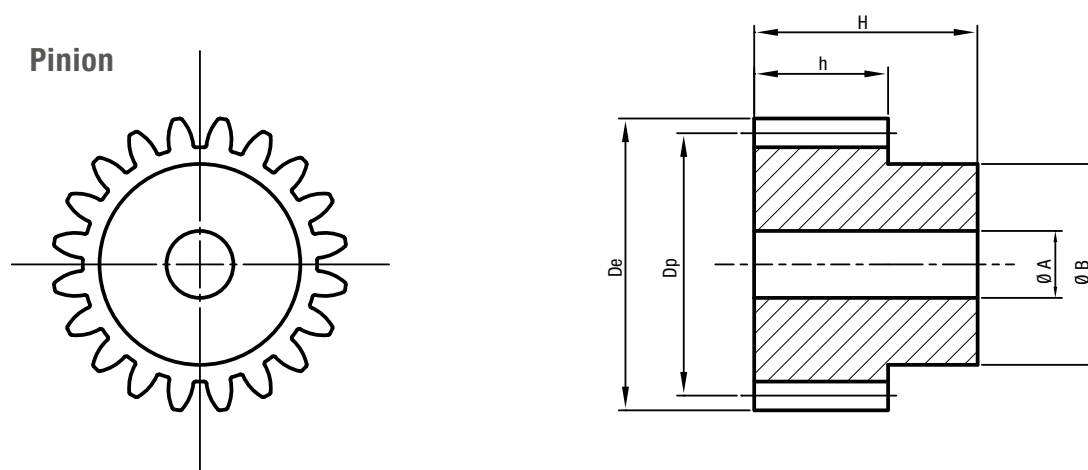

Type		Z	m	D_e	D_p	h	H	A H7	B	Weight (Kg)
PZ20M15HD	Material: C45	20	m 1.5	33	30	17	30	8	25	0.13
PZ20M20HD	Milled teeth	20	m 2	44	40	20	35	10	30	0.26
PZ20M30HD	Induction hardened	20	m 3	66	60	30	50	14	45	0.84

Straight teeth | Pressure angle 20° | Other gear type available on request

GUIDE FSHZ FSXZ

LUBRICATION WHEEL LUBZ..

5.1

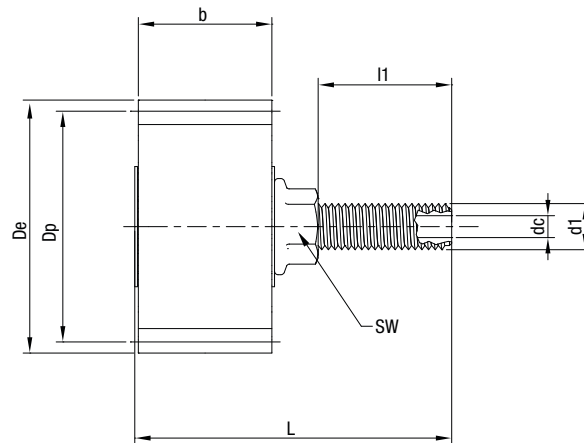

Type	Z	m	De	Dp	b	dc	d1	L	l1	SW	Weight (Kg)
LUBZ15D	24	m 1.5	39	36	15	M6	M10	60.2	34	17	0.07
LUBZ20D	17	m 2	38	34	20	M6	M10	61	30	17	0.08
LUBZ30D	17	m 3	57	51	30	M6	M10	71	30	17	0.11

V-LINE – FS SYSTEM

LUBRICATOR LUBY

FOR FS GUIDE ROLLERS UP TO SIZE 40

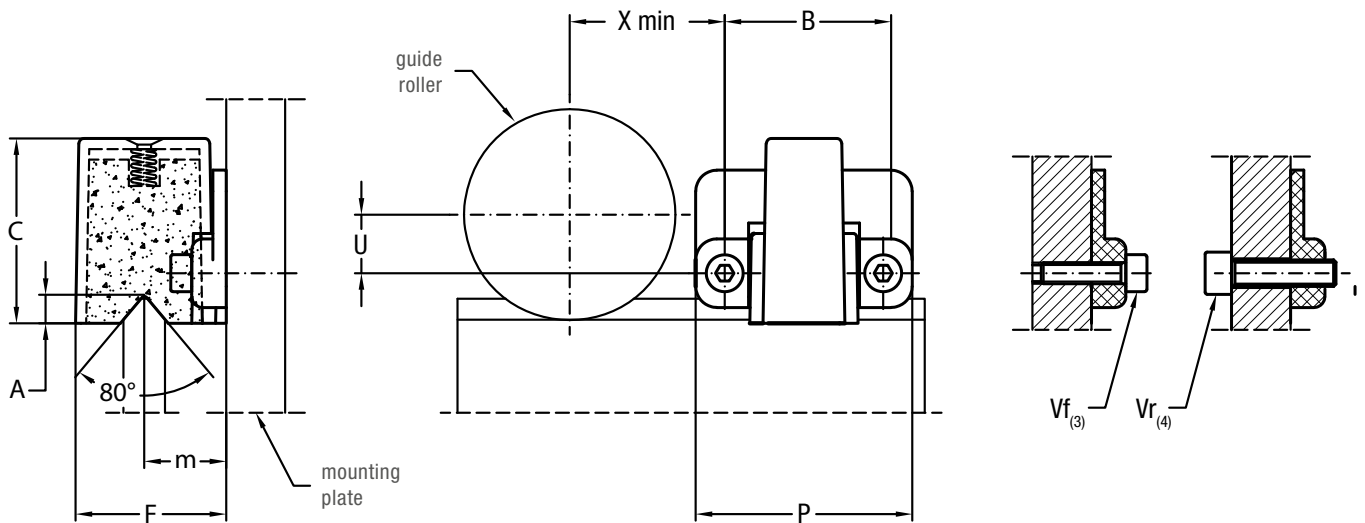
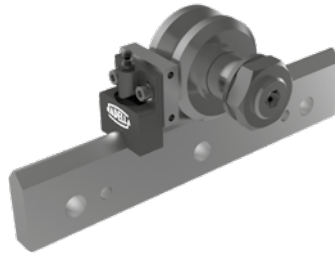

Type	Dimensions (mm)										Weight (g)	Suggested combinations
	X	U	B	F	m	A	C	P	Vf ¹⁾	Vr ²⁾		
LUBY 19	15	1.5	25	15.6	8.8	2.5	19	32.5	M3 x 12	M4	10	FR ... 19 ...
LUBY 22	16.5	3	25	16.8	9.4	3.3	22	32.5	M3 x 12	M4	10	FR ... 22 ...
LUBY 32	21.5	8	25	23.2	12.6	4.2	30	32.5	M3 x 12	M4	15	FR ... 32 ...
LUBY 40	27.5	10.5	30	28.5	15.5	5.4	35	41	M4 x 16	M5	30	FR ... 40 ...

1) The screws Vf for the frontal mounting are included in the packaging. Arrange two thread holes for dimension Vf in the mounting rollers plate

2) The screws for the mounting on the nut side of the roller are not included in the packaging. Arrange on the mounting rollers plate the holes in order to insert the screws Vr

- The lubricator is supplied with the felt already lubricated. The lubricant has a mineral oil base
- At the mounting, insert the screws inside the rollers plate, without tightening them, adjust the height of the plastic part in order to put it in contact with the raceways and then block it

OPTIONAL FEATURES

- Felt without lubricant (D)

LUBRICATOR LUBY, LUBX FOR FS GUIDE ROLLERS SIZE 52 AND HIGHER

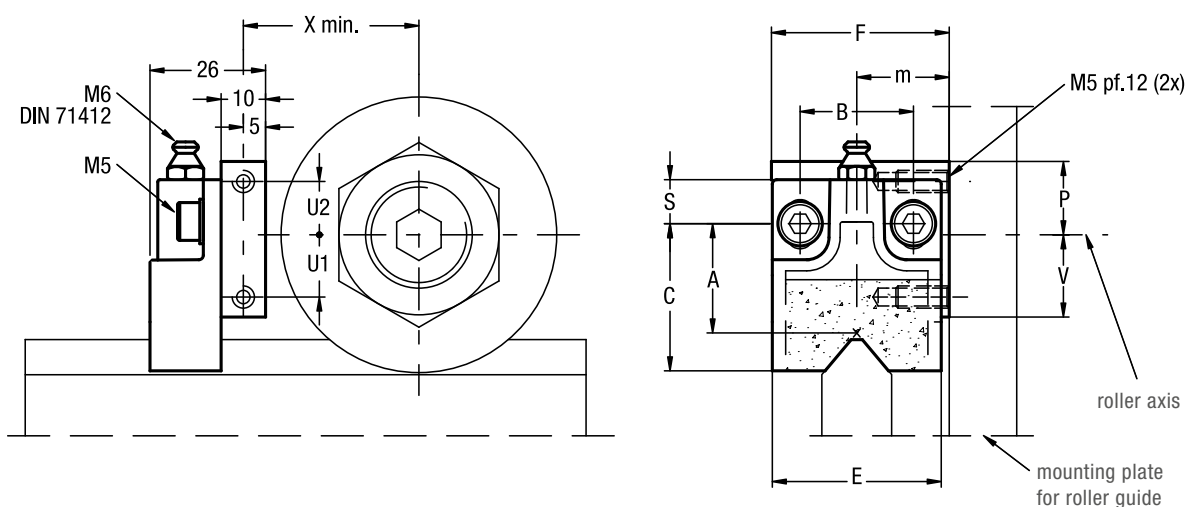
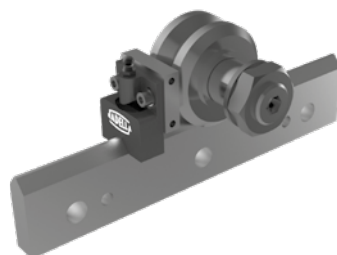

Type	Dimensions (mm)												Weight (g)	Suggested combinations
	X	U1	U2	F	m	B	S ¹⁾	C ¹⁾	A ¹⁾	E	V	P		
LUBY 52	33.5	12	14	40	19.8	25.5	10	34	24.5	38	16.5	18.5	65	RKY 52, RKYR 52, FKY 52, FR 52 EU, FRR 52, EU ... AS/AZ
LUBY 62	38.5	14	12	40	20.8	25.5	10	34	24.5	38	18.5	16.5	65	RKY 62, RKYR 62, FKY 62, FR 62 EU, FRR 62, EU ... AS/AZ
LUBY 72	43.5	19	11	50	27	25.5	10	40	29	44	24	16	85	RKY 72, RKYR 72, FKY 72
LUBX 90	52.5	21	9	60	27	30	16.5	45.5	33.5	58	31	19	140	RKX 90 C, RKXR 90 C, FKX 90 C
LUBX 110	62.5	30	0	63	34	30	16.5	45.5	33.5	58	40	10	140	RKX 110 C, RKXR 110 C, FKX 110 C

1) The dimension of the plastic part refers to the centre of the regulation slot. The regulation slot allows a translation of +/- 3 mm

- The lubricator is supplied with the felt already lubricated. The lubricant has a mineral oil base
- During the mounting fix the aluminium support to the rollers plate, adjust the height of the plastic part in order to put it in contact with the raceways and than block it in that position with the M5 screws

OPTIONAL FEATURES

- Felt without lubricant (D)

V-LINE – FS SYSTEM

GUIDE ROLLERS COMBINATION

Guide rollers FR ... EU, FR ... EU AS, FR ... EU AZ, FRN ... EI, RKY, RKX, FKY, FRL ... EU, RKXL, RKYL.

FS

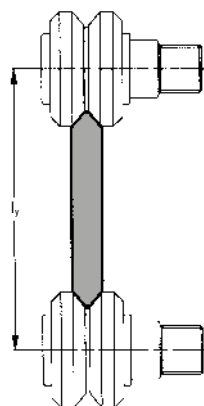

FS ... MT

I _y (mm)	Guide roller size						
	19 ...	22 ...	32 ...	40 ...	52 ...	62 ...	72 ...
FS 19 MT	36.2	37.6					
FS 22 MT		44.2					
FS 32 MT			67.4				
FS 35 MT			72.4	78 ¹⁾			
FS 40 MT			88.1 ¹⁾	93.7			
FS 47 MT				109.3 ¹⁾	118.3		
FS 52 MT					129.5	135.5 ¹⁾	
FS 62 MT					144.2	150.2	
FS 72 MT						168.8 ¹⁾	175.6

1) Possible combination

FS ... M

I _y (mm)	Guide roller size						
	19 ...	22 ...	32 ...	40 ...	52 ...	62 ...	72 ...
FS 19 M	35	36.4					
FS 22 M	41.9	43.3					
FS 32 M			66.5				
FS 35 M			71.5	77 ²⁾			
FS 40 M			87.2	92.8			
FS 47 M				107.8 ²⁾	116.8		
FS 52 M					128	134 ²⁾	
FS 62 M					143	149	
FS 72 M						167.2 ²⁾	174

2) Possible combination

FSH / FSX

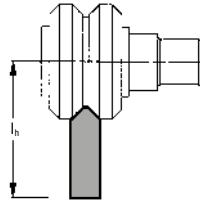

FSH ... MT, FSX ... MT

I _h (mm)	Guide roller size								
	19 ...	22 ...	32 ...	40 ...	52 ...	62 ...	72 ...	90 ...	110 ...
FSH 22 MT	30.9	31.6							
FSH 32 MT			41.7						
FSH 40 MT			49 ³⁾	51.8					
FSH 52 MT				55.4 ³⁾	59.9				
FSH 62 MT					69.9 ³⁾	72.9			
FSH 72 MT						83 ³⁾	86.4		
FSX 90 MT								95.3	102.3

3) Possible combination

FSH ... M, FSX ... M

I _h (mm)	Guide roller size								
	19 ...	22 ...	32 ...	40 ...	52 ...	62 ...	72 ...	90 ...	110 ...
FSH 19 M	26	26.7							
FSH 22 M	29.9 ⁴⁾	30.6							
FSH 32 M			40.7						
FSH 40 M			48 ⁴⁾	50.9					
FSH 52 M				54 ⁴⁾	58.5				
FSH 62 M					68.5 ⁴⁾	71.5			
FSH 72 M						81.6 ⁴⁾	85		
FSX 90 M								94.3	101.3

4) Possible combination

V-LINE – FS SYSTEM MOUNTING EXAMPLES

Waterjet cutting machine
V-Line

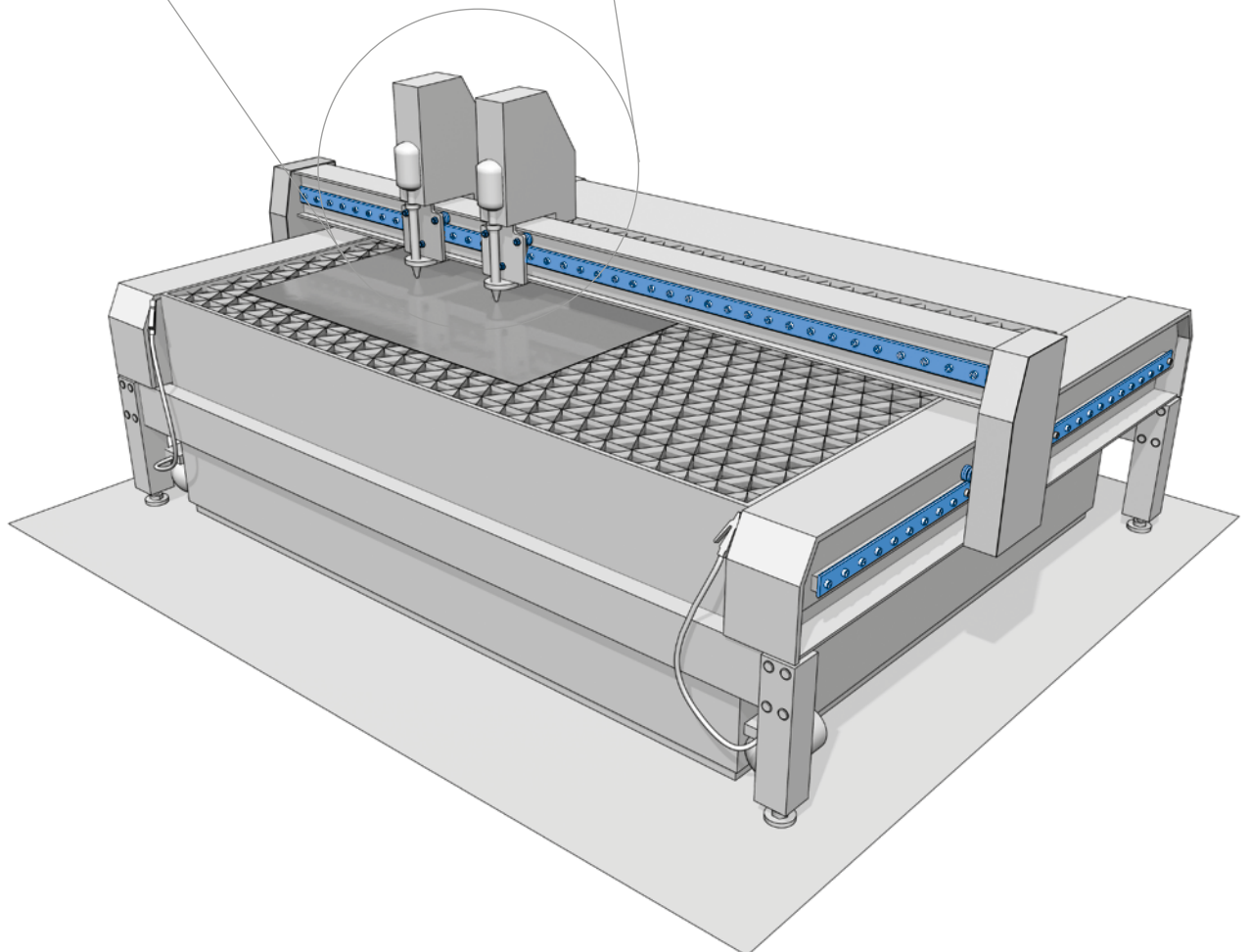
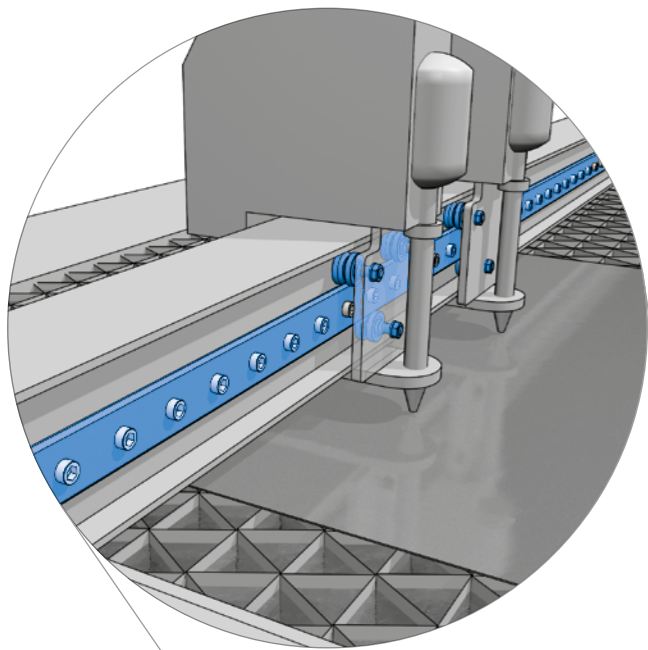

5.3

Portable loader for steel sheet
V-Line
Heavy-Line

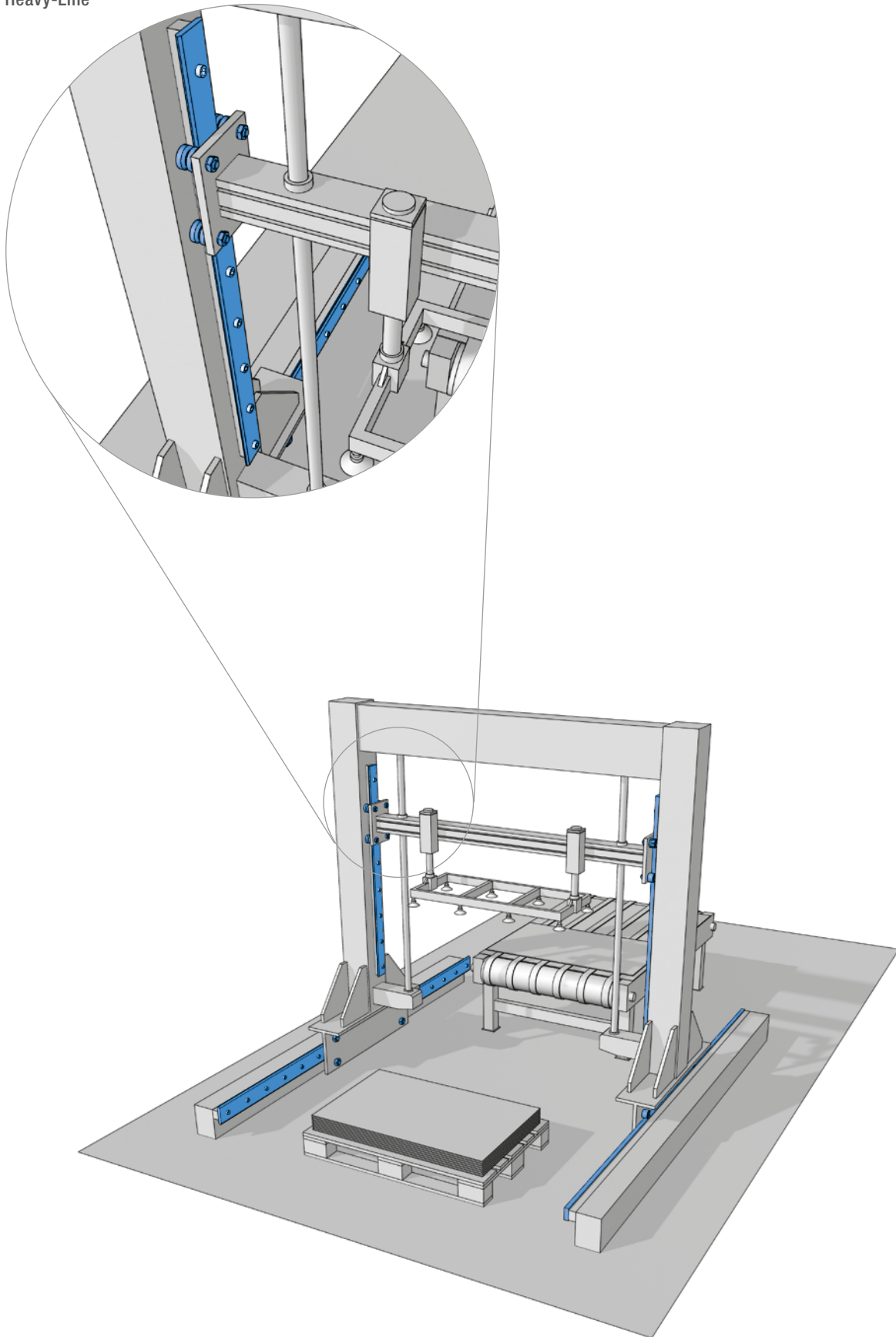

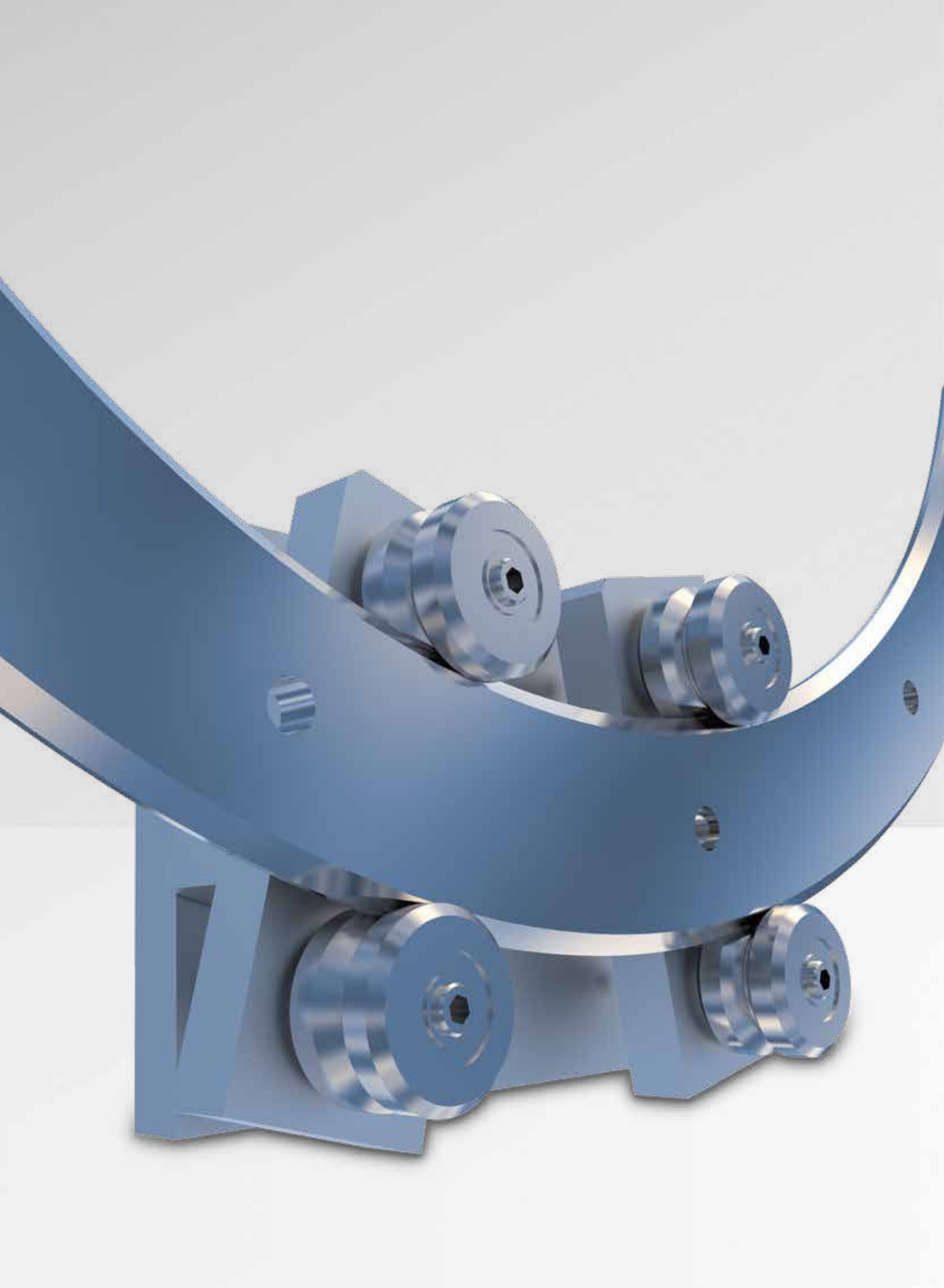

MULTI-MOTION-LINE

6

PAGE 72

6.1 CIRCULAR SYSTEMS

PAGE 73

6.2 FSR SYSTEM

- Circular rails FSR ... M
- Alignment blocks for FSR
- Oval circuit FSR0
- Ring circuit FSRQ
- Carriages with fixed guide rollers T4R ...
- Steering carriage T4R ...
- Lubrication system LUBR.. for circular systems

PAGE 79

6.3 MOUNTING EXAMPLES

MULTI-MOTION-LINE CIRCULAR SYSTEMS

KEY BENEFITS

- Circular rails based on the profiles of V-Line (FS guides)
- Circular rails, oval circuits and ring circuits
- Rolled vertical guides for oversized radii
- Protection against corrosion by special surface treatment



NADELLA proposes several circular rails based on the FS family of profiles. The rails can be used as an entire circumference, or single sectors, or joined together with straight pieces of rail in order to obtain oval or ring circuits.

GUIDE

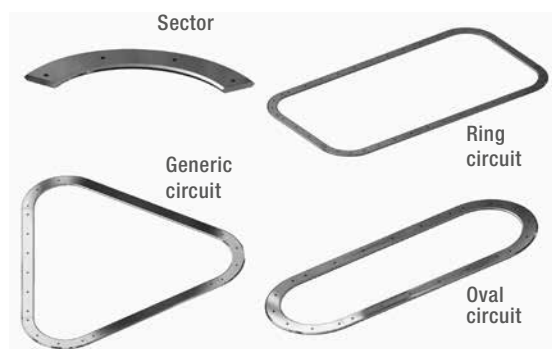

The rails are steel, induction hardened on the raceways, with the same section dimensions as straight FS ... M rails. In the circuits the rails are joined together with alignment blocks that allow easy precise mounting. All the pieces of the circuit are supplied appropriately marked in order to avoid mistakes during joining. For protection against corrosion NADELLA proposes nickel plating (option NW) for both straight and circular pieces. On request, guides can be supplied in stainless steel (NX option). In addition to the standard dimensions in the table it is possible to realize rings with different sections or radii in order to satisfy specific demands.

GUIDE ROLLERS

Any guide rollers of the FS family of products can be used in combination with the circular rails.

CARRIAGE

Carriages for circular rails can be realized with guide rollers in fixed position or mounted on steering arms.

CARRIAGES WITH GUIDE ROLLERS IN FIXED POSITIONS

You can set up the distance between the centres of the guide rollers of a carriage with fixed guide rollers in order to obtain clearance-free running both on the straight and on the circular stretch of a circuit. The resulting carriage, normally a simple table with four holes for the housing of the guide rollers, will be simple and compact; there are however, some contraindications:

- In the passage from the straight stretch to the circular one (and vice versa), when two guide rollers are engaged on the straight portion and two on the circular one, there will be clearance between the carriage and the rail. The extent of the clearance

depends on the dimensions of the rail, of the roller guides and of the carriage. Because of this clearance it is not possible to have an accurate positioning of the carriage during the passage between straight and circular stretch and therefore, in fast application, there will be vibration, noise and overload of the roller guides.

- This kind of carriages, with fixed guide rollers, can be used only for a single specific radius throughout the circuit. To use a carriage with fixed guide roller positions you can't have circular stretches with different radii.

To define the design for holes of the fixed rollers please contact the NADELLA Technical Service.



STEERING CARRIAGES

The contraindications for the carriage with guide rollers in fixed positions can be resolved by using the steering carriage. Guide rollers are mounted in pairs on steering arms that are free to rotate in order to always be transversal to the rail in every point of the circuit. The carriage won't have clearance at any point in the circuit improving transition area accuracy and reduce running noise. The studs of the steering carriage are fitted with needle bearings and seals for lubricant retention and protection. The tightening of the stud is obtained by the full tightening of the nut, and guarantees the best locking.



CIRCULAR RAILS FSR ... M

Circular rail in steel.

Available in stainless steel version.

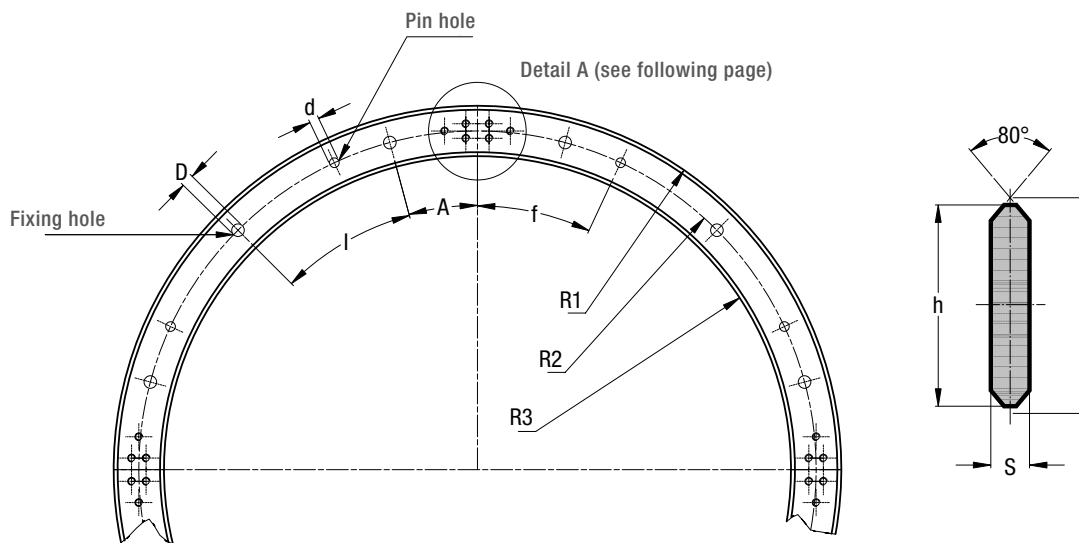

Type	Dimensions (mm)											n° fixing holes / 360°	n° pin holes / 360°
	A	I	f	d H7	D	R1 ¹⁾	R2 ¹⁾	R3 ¹⁾	h	H	S		
FSR 22 M 075	22.5°	45°	45°	5	6.5	88	75	62	26	27.86	5	8	4
FSR 22 M 125	15°	30°	25°	5	6.5	138	125	112	26	27.86	5	12	8
FSR 22 M 175	15°	30°	25°	5	6.5	188	175	162	26	27.86	5	12	8
FSR 35 M 225	11.25°	22.5°	7.5°	8	9	248	225	202	46	47.86	8	16	8
FSR 35 M 300	11.25°	22.5°	7.5°	8	9	323	300	277	46	47.86	8	16	8
FSR 47 M 400	9°	18°	18°	10	11.5	438	400	362	76	78.58	10	20	8
FSR 47 M 500	9°	18°	18°	10	11.5	538	500	462	76	78.58	10	20	8

¹⁾ R1, R2, R3 are radius

RAILS FINISHING

- Steel
- Induction hardened on the raceways

HOLE LAYOUT

- Holes according to catalogue (SB)
- Finishes to drawing (NZ)

OPTIONAL FEATURES

- Stainless steel (NX)
- Nickel plating (NW)
- Spacers for rails FS and FSH

Example of standard designation: FSR 35 M 225 180
Circular rail sector FSR 35 M, radius R2 225 mm, sector angle 180°

MULTI-MOTION-LINE – FSR SYSTEM

ALIGNMENT BLOCKS FOR FSR

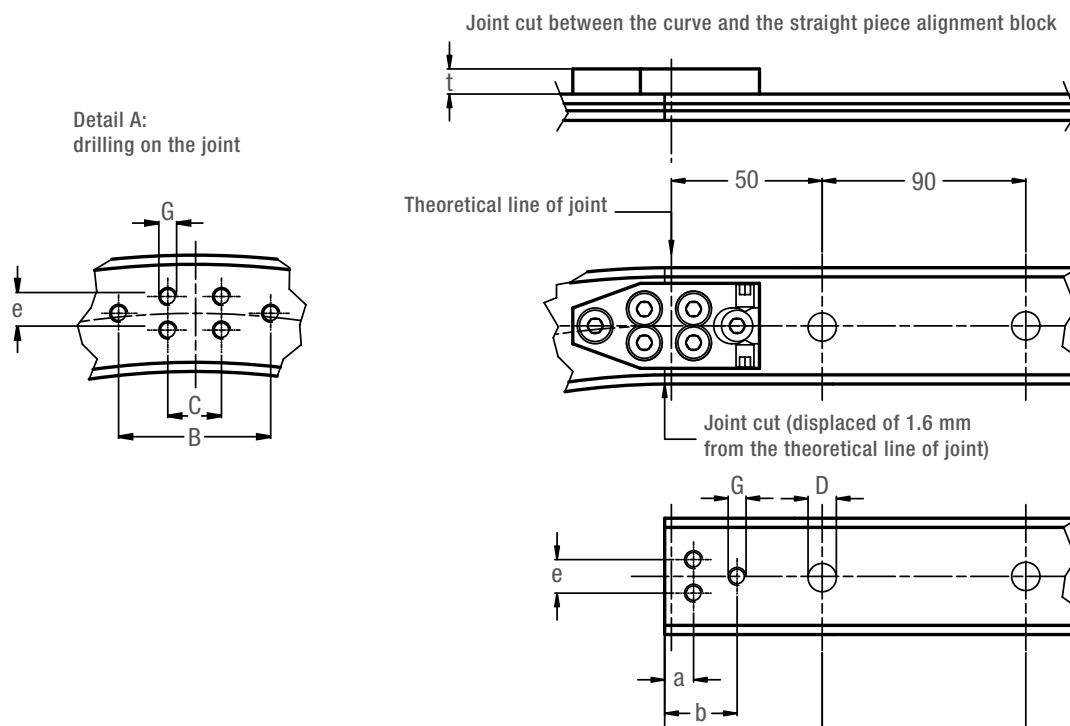

Type	Dimensions (mm)								Suggested combinations
	C	B	e	G	D	a	b	t	
FSR 22 M 075	12	34	7.5	M4	6.5	7.6	18.6	5.8	FR 22 EU, FRN 22 EI
FSR 22 M 125	12	34	7.5	M4	6.5	7.6	18.6	5.8	FR 22 EU, FRN 22 EI
FSR 22 M 175	12	34	7.5	M4	6.5	7.6	18.6	5.8	FR 22 EU, FRN 22 EI
FSR 35 M 225	18	38	20	M6	9	10.6	19.6	8	FR 32 EU, FRN 32 EI, FR 40 EU, FRN 40 EI
FSR 35 M 300	18	38	20	M6	9	10.6	19.6	8	FR 32 EU, FRN 32 EI, FR 40 EU, FRN 40 EI
FSR 47 M 400	18	58	43	M6	11.5	8.6	18.1	9	FR 40 EU, FRN 40 EI, FR 52 EU, RKY 52
FSR 47 M 500	18	58	43	M6	11.5	8.6	18.1	9	FR 40 EU, FRN 40 EI, FR 52 EU, RKY 52

The joint cut is displaced of 1.6 mm from the theoretical line of joint.
The alignment block allows an easy mounting of the joint.

SPACERS FOR FSR

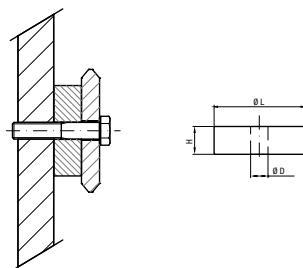

Spacers DIST FS can be used to mount the rails FSR (spacers for rails FS and FSH). See page 61

OVAL CIRCUIT FSRO

Oval circuit composed of linear and circular pieces of rail.

Available in stainless steel version.

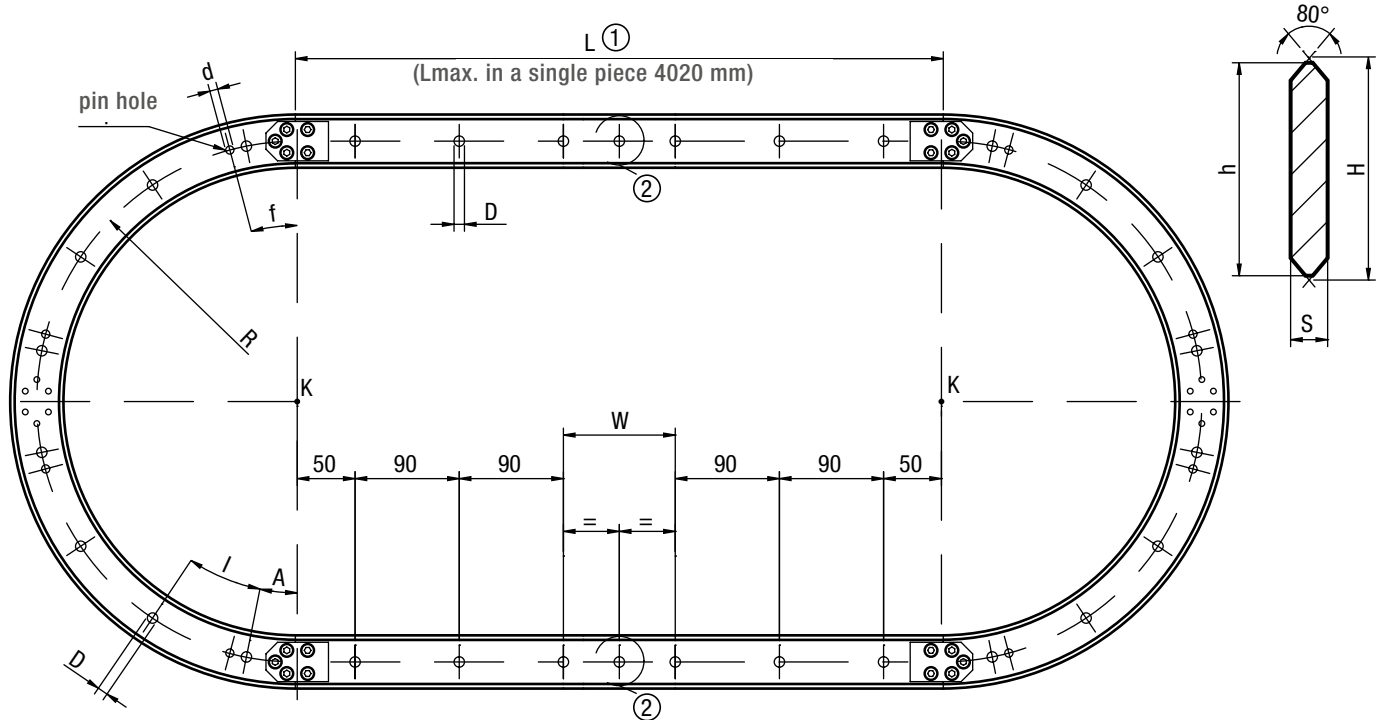

Type	Dimensions (mm)								
	A	I	f	Radius R	D	d H7	S	h	H
FSRO 22 M 075 ...	22.5°	45°	45°	75	6.5	5	5	26	27.86
FSRO 22 M 125 ...	15°	30°	25°	125	6.5	5	5	26	27.86
FSRO 22 M 175 ...	15°	30°	25°	175	6.5	5	5	26	27.86
FSRO 35 M 225 ...	11.25°	22.5°	7.5°	225	9	8	8	46	47.86
FSRO 35 M 300 ...	11.25°	22.5°	7.5°	300	9	8	8	46	47.86
FSRO 47M 400 ...	9°	18°	18°	400	11.5	10	10	76	78.58
FSRO 47M 500 ...	9°	18°	18°	500	11.5	10	10	76	78.58

The oval circuit is composed by: two sectors of circular rails (180° with center in K) and two straight pieces of rails. The circuit is supplied complete of alignment blocks (with the proper screws), and all the pieces are marked in order to obtain the correct sequence during the mounting.

① The length of the straight pieces is higher than the distance between the centers K (1.6 mm x 2) in order to cover the thickness of rail lost during the cutting of the circular sectors.

STANDARD HOLE LAYOUT (SB) FOR THE STRAIGHT RAILS

- First and last hole of 50 mm, starting from the centers K
- Hole pitch 90 mm
- Central hole ② only if the last hole pitch W is ≥ 120 mm
- The W pitch can not be less than 60 mm

RAILS FINISHING

- Circular rail FSR ... M
- Guide rail FS ... M
- Alignment blocks for FSR

HOLE LAYOUT

- Standard holes according to catalogue (SB)
- Finishes to drawing (NZ)

OPTIONAL FEATURES

- Stainless steel (NX)
- Nickel plating (NW)

Example of standard designation: FSRO 35 M 225 2000 SB
Oval circuit, size 35, radius 225 mm, distance between the centers K equal to 2000 mm ①, standard holes.

MULTI-MOTION-LINE – FSR SYSTEM

RING CIRCUIT FSRQ

Ring circuit composed of linear and circular pieces of rail.

Available in stainless steel version.

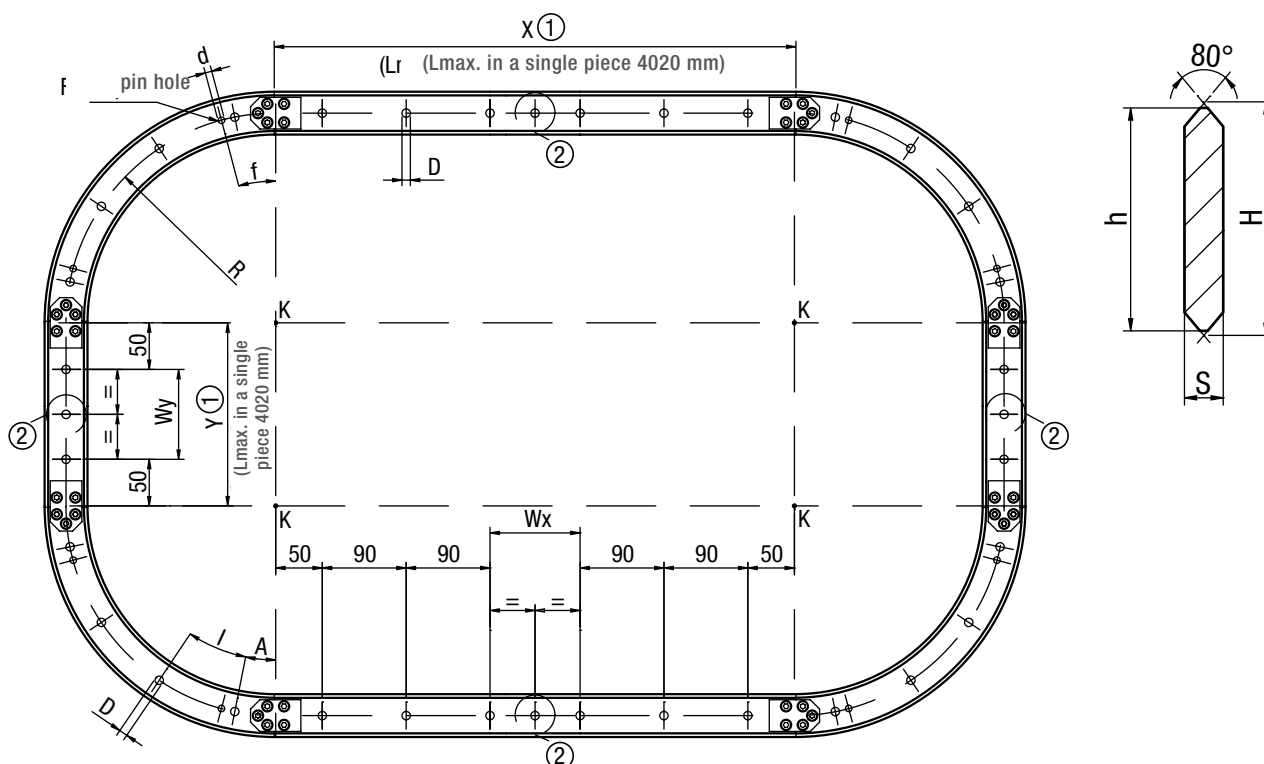

Type	Dimensions (mm)								
	A	I	f	Radius R	D	d H7	S	h	H
FSRQ22 M 075 ...	22.5°	45°	45°	75	6.5	5	5	26	27.86
FSRQ22 M 125 ...	15°	30°	25°	125	6.5	5	5	26	27.86
FSRQ22 M 175 ...	15°	30°	25°	175	6.5	5	5	26	27.86
FSRQ35 M 225 ...	11.25°	22.5°	7.5°	225	9	8	8	46	47.86
FSRQ35 M 300 ...	11.25°	22.5°	7.5°	300	9	8	8	46	47.86
FSRQ47 M 400 ...	9°	18°	18°	400	11.5	10	10	76	78.58
FSRQ47 M 500 ...	9°	18°	18°	500	11.5	10	10	76	78.58

The ring circuit is composed by: four sectors of circular rails (90° with center in K) and four straight pieces of rails. The circuit is supplied complete of alignment blocks (with the proper screws), and all the pieces are marked in order to obtain the correct sequence during the mounting.

① The length of the straight pieces is higher than the distance between the centers K (1.6 mm x 2) in order to cover the thickness of rail lost during the cutting of the circular sectors

STANDARD HOLE LAYOUT (SB) FOR THE STRAIGHT RAILS

- First and last hole at 50 mm, starting from the centers K
- Hole pitch 90 mm
- Central hole ② only if the last hole pitch (Wx in horizontal and Wy in vertical) is ≥ 120 mm (Wx in horizontal and Wy in vertical) cannot be < 60 mm

RAILS FINISHING

- Circular rail FSR ... M
- Guide rail FS ... M
- Alignment blocks for FSR

HOLE LAYOUT

- Standard holes according to catalogue (SB)
- Finishes to drawing (NZ)

OPTIONAL FEATURES

- Stainless steel (NX)
- Nickel plating (NW)

Example of standard designation: FSRQ 35 M 225 2000 1000 / SB
 Ring circuit, size 35, radius 225 mm, horizontal distance between the centers K equal to 2000 mm ①, vertical distance between the centers K equal to 1000 mm ①, standard holes.

CARRIAGES WITH FIXED GUIDE ROLLERS T4R ...

Available in stainless steel version.

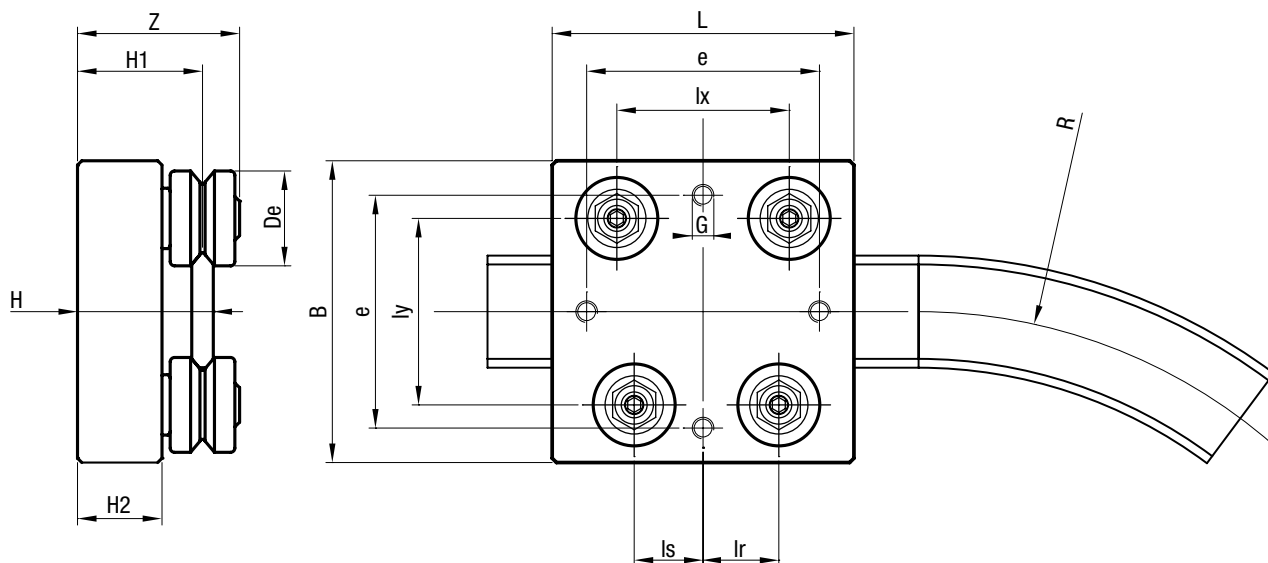

Type	Dimensions (mm)														Weight (kg)	Suggested combinations
	De	R	L	B	e	G	lx	ls	lr	ly	H	H1	H2	Z		
T4R 075 FR 22 EU	22	75	70	70	54	M5	40	14.3	15.3	43.3	31.5	29	19.6	38	0.40	FSR ... 22 M 075
T4R 125 FR 22 EU	22	125	70	70	54	M5	40	16.3	17.3	43.3	31.5	29	19.6	38	0.40	FSR ... 22 M 125
T4R 175 FR 22 EU	22	175	70	70	54	M5	40	17.2	18.2	43.3	31.5	29	19.6	38	0.40	FSR ... 22 M 175
T4R 225 FR 32 EU	32	225	110	110	90	M8	70	28.8	30.8	71.5	44	40	27.4	51	1.22	FSR ... 35 M 225
T4R 225 FR 40 EU	40	225	120	120	100	M8	75	30.5	32.5	77	49	45	29.5	60	1.90	FSR ... 35 M 225
T4R 300 FR 32 EU	32	300	110	110	90	M8	70	30	32	71.5	44	40	27.4	51	1.22	FSR ... 35 M 300
T4R 300 FR 40 EU	40	300	120	120	100	M8	75	31.9	33.9	77	49	45	29.5	60	1.90	FSR ... 35 M 300
T4R 400 FR 40 EU	40	400	150	150	126	M10	104	44.4	46.4	107.8	50	45	29.5	60	2.5	FSR ... 47 M 400
T4R 400 FR 52 EU	52	400	180	180	156	M10	110	46	49	116.8	59	54	34.2	71	4.7	FSR ... 47 M 400
T4R 400 RKY 52	52	400	180	180	156	M10	110	46	49	116.8	59	54	34.2	76	5.1	FSR ... 47 M 400
T4R 500 FR 40 EU	40	500	150	150	126	M10	104	45.7	47.7	107.8	50	45	29.5	60	2.5	FSR ... 47 M 500
T4R 500 FR 52 EU	52	500	180	180	156	M10	110	47.4	50.4	116.8	59	54	34.2	71	4.7	FSR ... 47 M 500
T4R 500 RKY 52	52	500	180	180	156	M10	110	47.4	50.4	116.8	59	54	34.2	76	5.1	FSR ... 47 M 500

OPTIONAL FEATURES

- Available with stainless steel guide rollers (NX)
- Carriages are complete with guide rollers

MULTI-MOTION-LINE – FSR SYSTEM

STEERING CARRIAGE T4R ...

6.2

Steering carriage for FSR ... M circular rails

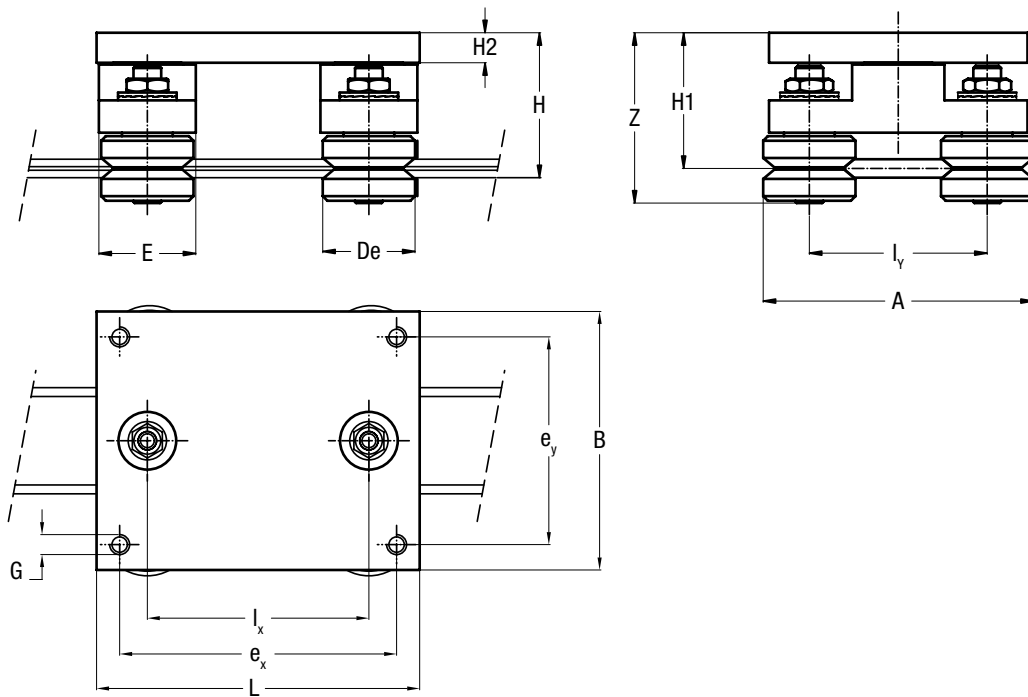

Type	Dimensions (mm)														Weight (kg)	Suggested combinations
	De	L	B	ex	ey	Ix	Iy	H	H1	H2	G	A	E	Z		
T4R 22 FR 22 EU T4R 22 FRN 22 EI	22	80	62	68	50	50	43.3	45.5	43	12	M5	65.3	27	51.6 53.6	0.5	FSR 22 M, FS 22 M
T4R 35 FR 32 EU T4R 35 FRN 32 EI	32	140	112	120	90	96	71.5	59.9	55.9	13	M8	103.5	42	66.2 69.3	1.1	FSR 35 M, FS 35 M
T4R 35 FR 40 EU T4R 35 FRN 40 EI	40	140	112	120	90	96	77	62.8	58.8	13	M8	117	42	72.8 74.3	1.6	FSR 35 M, FS 35 M
T4R 47 FR 40 EU T4R 47 FRN 40 EI	40	180	160	150	130	120	107.8	74.3	69.3	19	M10	147.8	56	83.3 84.8	2.4	FSR 47 M, FS 47 M
T4R 47 FR 52 EU T4R 47 RKY 52	52	180	160	150	130	120	116.8	78.6	73.6	19	M10	168.8	56	90.3 94.8	3.3	FSR 47 M, FS 47 M

LUBR

LUBRICATOR SYSTEM FOR CIRCULAR RAILS

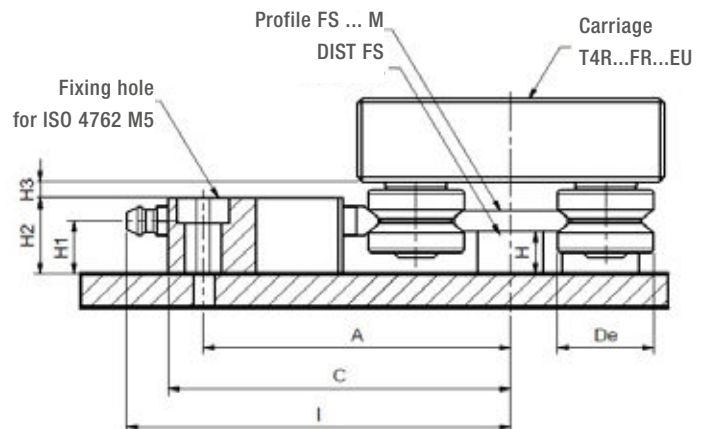
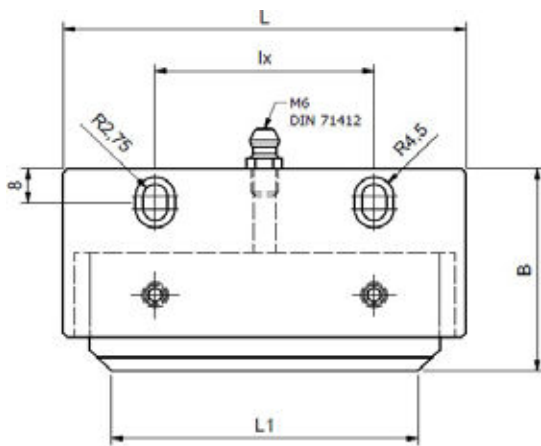

Type	To couple with	Dimensions (mm)												Weight (kg)
		De	L	L1	A	B	C	I	I _x	H	H ₁	H ₂	H ₃	
LUBR 22	FSR22M + FR22EU+DISTFS22	22	92	70	70	48	78.3	87.8	50	10	12.5	18	3.9	0.2
LUBR 35	FSR35M + FR32EU+ DISTFS35	32	160	130	88	48	96.5	106	100	15	19	26	5.6	0.4
	FSR35M + FR40EU+ DISTFS35	40	160	130	94	48	102	111.6	100	15	19	26	5.6	0.4
LUBR 47	FSR47M + FR40EU+ DISTFS47	40	202	170	110	48	117.8	127.3	120	20	25	33	7.5	0.7
	FSR47M + FR52EU+ DISTFS47	52	202	170	119	48	126.8	136.3	120	20	25	33	7.5	0.7
	FSR47M + RKY52+ DISTFS47	52	202	170	119	48	126.8	136.3	120	20	25	33	7.5	0.7

1) The lubricator is supplied with felt already soaked in oil. Lubricant based on mineral oil.

2) During assembly, use the aluminum body of the lubricator to adjust the distance between the felt and the rollers until they are in contact with each other. Then secure the body with the M5 screws.

OPTIONAL FEATURES

- Felt without lubricant (D)

MOUNTING EXAMPLE

Assembly line
Multi-Motion-Line

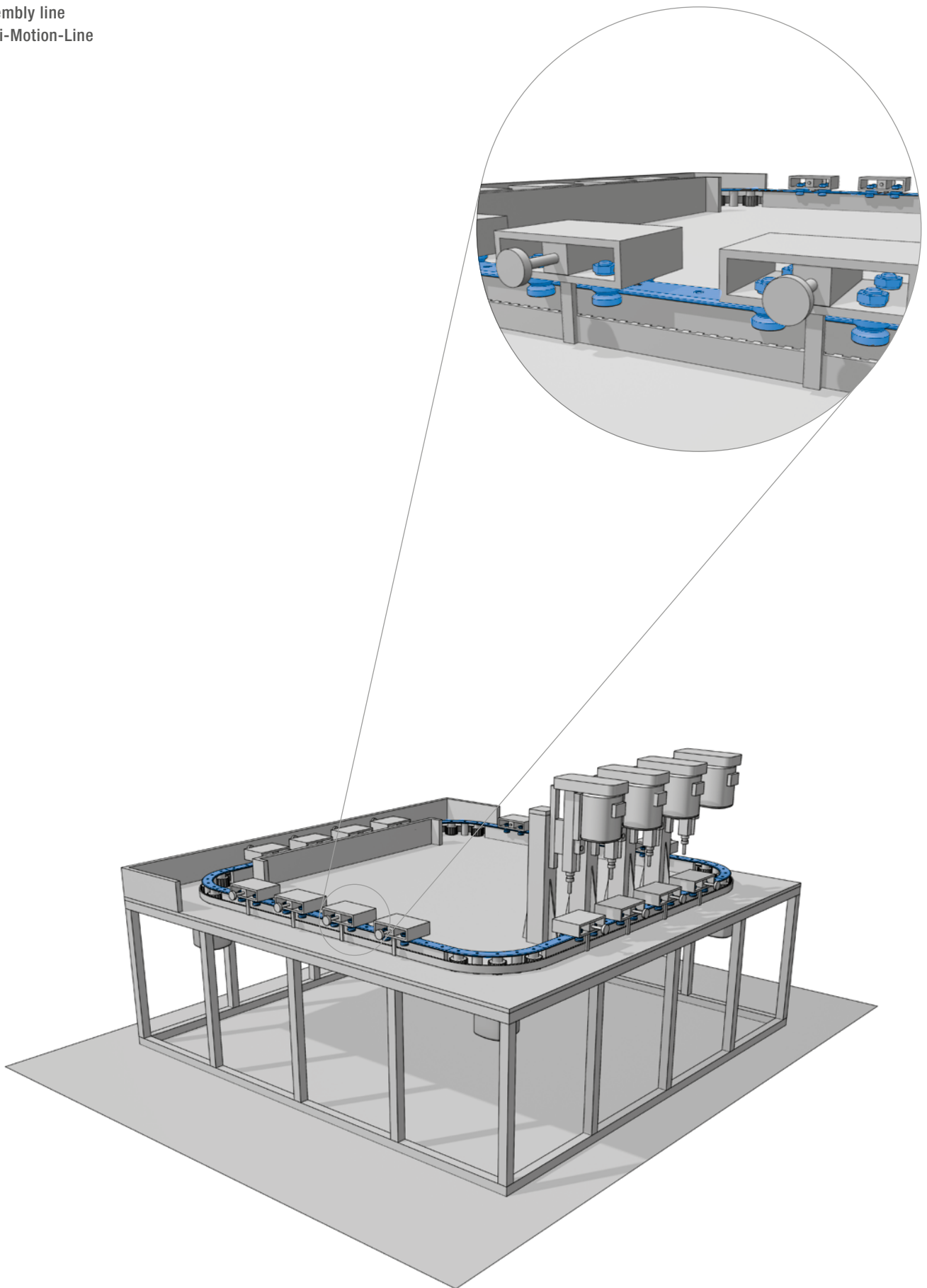



C-LINE



PAGE 84

7.1 PRODUCT DESCRIPTION

PAGE 90

7.2 SYSTEM LS

- For light-medium loads
- Guide rails LS
- Guide rollers RCS
- Guide rollers RAS
- Guide rollers RCN
- Guide rollers RAN
- Carriages C3 RCS, C3 RAS, C3 RYS
- Carriages C4 RCS, C4 RAS, C4 RYS
- Carriages C5 RCS, C5 RAS, C5 RYS
- Carriages C3 RCN, C3 RAN, C3 RYN
- Carriages C4 RCN, C4 RAN, C4 RYN
- Carriages C5 RCN, C5 RAN, C5 RYN
- Carriages C6 RCN, C6 RAN, C6 RYN

C-LINE

PRODUCT DESCRIPTION

KEY BENEFITS

- High balance of mounting surface errors and misalignment
- Guide rollers for fixed and floating bearing constructions
- Easy smooth running
- High speeds up to 8 m/s
- Integrated lubricating system

With the new C-Line family, NADELLA aims to offer a complete product line: the LS guides, available in 3 sizes; the guide rollers, also available in floating version cursors with 3, 4, 5 and 6 rollers already available in stock. The cold drawn rails have a C shape and the internal raceways are induction hardened. The guide rollers slide inside the rails, in this way, they are protected from any accidental impacts. The guides are zinc-plated as standard and can also be supplied nickel-plated for more aggressive environments.

The use of floating guide rollers, coupled with “fixed” rollers, allows to obtain a self-aligning system, able to balance possible axial or transversal misalignment errors between two parallel guides.

NADELLA has the advantage of using a single driving profile for both types of rollers. The C-line is available in three sizes and the guide rollers can be both centered and eccentric to allow adjustment of the play.

Sliders are available in two versions: sliders with central block in aluminum C.RCS ..., C.RAS ... and C.RYS and sliders with central block in steel C.RCN ..., C.RAN ... and C.RYN.

ESSENTIAL TECHNICAL FEATURES

- Steel rail, drawn, induction hardened
- Zinc-plated rail, alternatively with nickel-plated surface
- Rollers for fixed and floating bearing constructions
- High balance of mounting surface errors and misalignment
- High performance and rugged
- Rollers lubricated for life
- Dust resistant
- Easy fitting
- Easy smooth running
- High speeds up to 8 m/s (depending on roller size and application)
- Acceleration up to 20 m/s²
- Working temperatures up to 80°C possible
- Pitch of rail borings standard or according to customer drawings
- Integrated lubricating system at the front sides of the carriage

CARRIAGE CONFIGURATION: CARRIAGES WITH CENTRAL BLOCK IN ALUMINUM RCS, RAS AND RYS

The load capacity of the carriage shown in the following paragraphs refer to the following mounting configuration, where the guide rollers dashed lines represent the concentric guide rollers (—), while the eccentric rollers which allow the adjustment of the play, do not exhibit hatch (^).

SHORT CARRIAGE WITH 3 ROLLERS

Type C3 ...

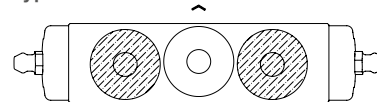

LONG CARRIAGE WITH 3 ROLLERS

Type C3 ... A

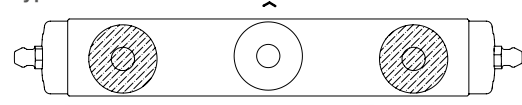

LONG CARRIAGE WITH 4 ROLLERS

Type C4 ... C

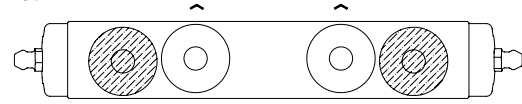

Type C4 ... A

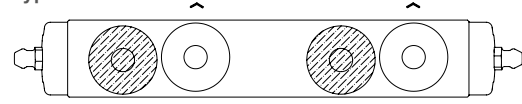

Type C4 ... B

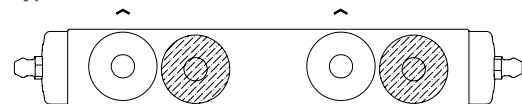

LONG CARRIAGE WITH 5 ROLLERS

Type C5 ... A

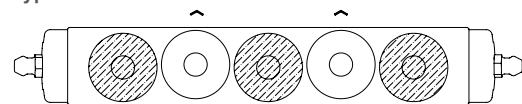

Type C5 ... B

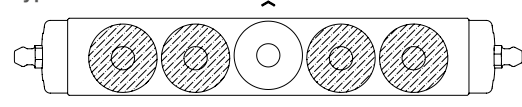

Views from above

The markings ^ and — show the contact points with the running surface of the rails

MAXIMUM LOAD CAPACITY OF SINGLE CARRIAGE

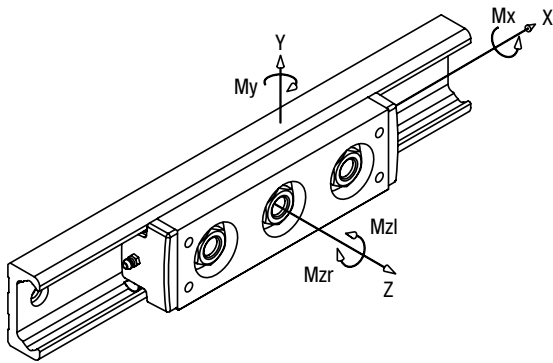

The load capacity charts must be considered when loads act exclusively in a single load direction (only along the Y axis or only along the Z axis). In case of combined loads the maximum load allowed will have lower values.

The tables below show the values of maximum loads applicable on a single carriage in relation to the axis system shown.

CARRIAGE CORTO CON 3 ROTELLE TYPE RCS, RAS E RYS

Guide	Carriage	Fy ¹⁾ (N)	Fz ²⁾ (N)	Mx ³⁾ (Nm)	My ²⁾ (Nm)	Mz ⁴⁾ (Nm)
LS 28	C3 RCS 28 126	2400	660	5.9	17	30
LS 43	C3 RCS 43 170	5500	1700	23	66	107
LS 63	C3 RCS 63 226	13000	4400	81	264	390

- 1) Fy directed to load the concentric wheels, valid for carriage type RCS, RAS and RYS
- 2) For carriages type RYS the load is reduced by 50%; load equal to ZERO for carriages type RAS
- 3) Mx equal to ZERO on carriages type RAS and RYS
- 4) Mz valid for carriages type RCS, RAS and RYS

LONG CARRIAGE WITH 3, 4 AND 5 WHEELS TYPE RCS, RAS AND RYS

Guide	Carriage	Fy ⁵⁾ (N)	Fz ⁶⁾ (N)	Mx ⁷⁾ (Nm)	My ⁶⁾ (Nm)	Mz ⁸⁾ (Nm)
						Mzl Mzr
LS 28	C3 RCS 28 178 A	2400	660	5.9	34	62 62
	C4 RCS 28 178 C	2400	1320	12	43	94 94
	C4 RCS 28 178 A	1800	990	8.9	38	125 62
	C4 RCS 28 178 B	1800	990	8.9	38	62 125
	C5 RCS 28 178 A	3000	1320	12	43	94 94
	C5 RCS 28 178 B	3600	660	5.9	35	62 62
	LS 43	C3 RCS 43 245 A	5500	1700	23	129
C4 RCS 43 245 C		5500	3400	45	162	314 314
C4 RCS 43 245 A		4100	2380	34	129	418 209
C4 RCS 43 245 B		4100	2380	34	129	209 418
C5 RCS 43 245 A		6800	3400	45	162	314 314
C5 RCS 43 245 B		8200	1700	23	133	209 209

- 5) Fy directed to load the concentric wheels, valid for carriages type RCS, RAS and RYS
- 6) For carriages type RYS the load is reduced by 50%; load equal to ZERO for carriages type RAS
- 7) Mx equal to ZERO on carriage type RAS and RYS
- 8) Mz valid for carriages type RCS, RAS and RYS

DYNAMIC LOAD CAPACITY OF SINGLE CARRIAGE

The tables below show the dynamic load capacity that allows a nominal life of 100 km.

The nominal life of the carriage can be calculated using the following formula:

$$L_{10} = (C_i / P_i)^3 \times 100 \text{ km}$$

Where Ci and Pi are: the allowed dynamic loads (Ci) and the external loads (Pi) acting on the carriage in a particular direction of load (i).

SHORT CARRIAGE WITH 3 WHEELS TYPE RCS, RAS AND RYS

Guide	Carriage	Cy ⁹⁾ (N)	Cz ¹⁰⁾ (N)	CMx ¹¹⁾ (Nm)	CMY ¹⁰⁾ (Nm)	CMz ¹²⁾ (Nm)
						Mzl Mzr
LS 28	C3 RCS 28 126	4400	1100	9.6	27	55 55
LS 43	C3 RCS 43 170	13200	3600	48	142	257 257
LS 63	C3 RCS 63 226	28400	6700	124	403	852 852

- 9) Cy directed to load the concentric wheels, valid for cursor type RCS, RAS and RYS
- 10) For carriage type RYS the load is reduced by 50%; load equal to ZERO for cursor type RAS
- 11) CMx equal to ZERO for carriage type RAS and RYS
- 12) CMz valid for carriage type RCS, RAS and RYS

LONG CARRIAGE WITH 3, 4 AND 5 WHEELS TYPE RCS, RAS AND RYS

Guide	Carriage	Cy ¹³⁾ (N)	Cz ¹⁴⁾ (N)	CMx ¹⁵⁾ (Nm)	CMY ¹⁴⁾ (Nm)	CMz ¹⁶⁾ (Nm)
						Mzl Mzr
LS 28	C3 RCS 28 178 A	4400	1100	9.6	55	114 114
	C4 RCS 28 178 C	4400	2100	19	69	172 172
	C4 RCS 28 178 A	3300	1600	14	61	229 114
	C4 RCS 28 178 B	3300	1600	14	61	114 229
	C5 RCS 28 178 A	6600	2100	19	69	172 172
	C5 RCS 28 178 B	8800	1100	9.6	67	114 114
LS 43	C3 RCS 43 245 A	13200	3600	48	277	502 502
	C4 RCS 43 245 C	13200	7300	96	346	752 752
	C4 RCS 43 245 A	9900	5100	72	304	1003 502
	C4 RCS 43 245 B	9900	5100	72	304	502 1003
	C5 RCS 43 245 A	19800	7300	96	346	752 752
	C5 RCS 43 245 B	26400	3600	48	292	502 502

- 13) Cy directed to load the concentric wheels, valid for cursor type RCS, RAS and RYS
- 14) For carriage type RYS the load is reduced by 50%; load equal to ZERO for cursor type RAS
- 15) CMx equal to ZERO for carriage type RAS and RYS
- 16) CMz valid for carriage type RCS, RAS and RYS

C-LINE

PRODUCT DESCRIPTION

CARRIAGE CONFIGURATION: CARRIAGES WITH CENTRAL BLOCK IN STEEL RCN, RAN AND RYN

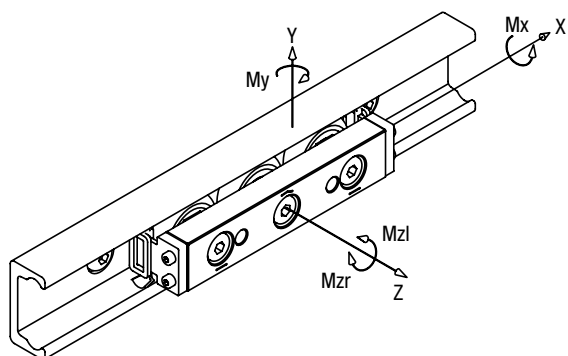

The load capacity of the carriage shown in the following paragraphs refer to the following mounting configuration, where the guide rollers dashed lines represent the concentric guide rollers (—), while the eccentric rollers which allow the adjustment of the play, do not exhibit hatch (↗).

SHORT CARRIAGE WITH 3 WHEELS

Type C3 ...

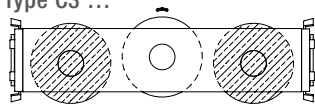

LONG CARRIAGE WITH 4 WHEELS

Type C4 ... A

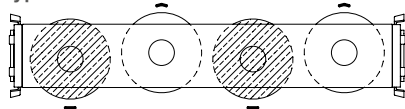

Type C4 ... B

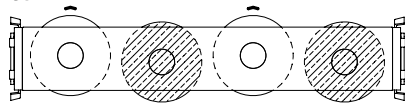

LONG CARRIAGE WITH 5 WHEELS

Type C5 ...

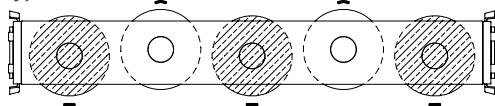

LONG CARRIAGE WITH 6 WHEELS

Type C6 ... A

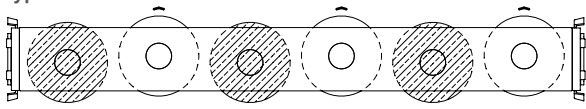

Type C6 ... B

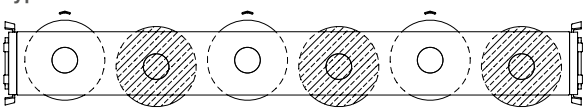

Views from above

The markings ↗ and — show the contact points with the running surface of the rails

MAXIMUM LOAD CAPACITY OF SINGLE CARRIAGE

The load capacity charts must be considered when loads act exclusively in a single load direction (only along the Y axis or only along the Z axis). In the case of combined loads the maximum load allowed will have lower values. The tables below show the values of maximum loads applicable to individual carriages in relation to the axis system shown.

SHORT CARRIAGE WITH 3 WHEELS TYPE RCN, RAN AND RYN

Guide	Carriage	Fy ¹⁾ (N)	Fz ²⁾ (N)	Mx ³⁾ (Nm)	My ²⁾ (Nm)	Mz ⁴⁾ (Nm)
LS 28	C3 RCN 28 080	2400	660	5.9	18	32
LS 43	C3 RCN 43 120	5500	1700	23	68	110
LS 63	C3 RCN 63 180	13000	4400	81	264	390

1) Fy directed to load the concentric wheels, valid for carriage type RCN, RAN and RYN

2) For carriages type RYN the load is reduced by 50%; load equal to ZERO for carriages type RAN

3) Mx equal to ZERO on carriages type RAN and RYN

4) Mz valid for carriages type RCN, RAN and RYN

LONG CARRIAGE WITH 3, 4, 5 AND 6 WHEELS TYPE RCN, RAN AND RYN

Guide	Carriage	Fy ⁵⁾ (N)	Fz ⁶⁾ (N)	Mx ⁷⁾ (Nm)	My ⁶⁾ (Nm)	Mz ⁸⁾ (Nm)	
						Mzl	Mzr
LS 28	C4 RCN 28 100 A	1600	750	7.7	18	90	30
	C4 RCN 28 100 B	1600	750	7.7	18	30	90
	C5 RCN 28 125	3000	1320	12	40	88	88
	C6 RCN 28 150 A	2200	1400	13	52	156	90
	C6 RCN 28 150 B	2200	1400	13	52	90	156
LS 43	C4 RCN 43 150 A	3650	1880	31	70	303	102
	C4 RCN 43 150 B	3650	1880	31	70	102	303
	C5 RCN 43 190	6800	3400	45	159	309	309
	C6 RCN 43 230 A	5000	3600	50	212	543	313
	C6 RCN 43 230 B	5000	3600	50	212	313	543
LS 63	C4 RCN 63 235 A	8670	4470	109	260	1131	377
	C4 RCN 63 235 B	8670	4470	109	260	377	1131
	C5 RCN 63 290	15600	8800	163	638	1131	1131
	C6 RCN 63 345 A	11830	8900	179	759	1927	1112
	C6 RCN 63 345 B	11830	8900	179	759	1112	1927

5) Fy directed to load the concentric wheels, valid for carriage type RCN, RAN and RYN

6) For carriages type RYN the load is reduced by 50%; load equal to ZERO for carriages type RAN

7) Mx equal to ZERO on carriages type RAN and RYN

8) Mz valid for carriages type RCN, RAN and RYN

DYNAMIC LOAD CAPACITY OF SINGLE CARRIAGE

The tables below show the dynamic load capacity that allows a nominal life of 100 km.

The nominal life of the carriage can be calculated using the following formula:

$$L_{10} = (C_i / P_i)^3 \times 100 \text{ km}$$

Where C_i and P_i are: the allowed dynamic loads (C_i) and the external loads (P_i) acting on the carriage in a particular direction of load.

SHORT CARRIAGE WITH 3 WHEELS TYPE RCN, RAN AND RYN

Guide	Carriage	$C_y^{(9)}$ (N)	$C_z^{(10)}$ (N)	$CM_x^{(11)}$ (Nm)	$CM_y^{(10)}$ (Nm)	$CM_z^{(12)}$ (Nm)
LS 28	C3 RCN 28 080	4400	1100	9.6	29	59
LS 43	C3 RCN 43 120	13200	3600	48	146	264
LS 63	C3 RCN 63 180	28400	6700	124	400	850

9) C_y directed to load the concentric wheels, valid for carriage type RCN, RAN and RYN

10) For carriages type RYS the load is reduced by 50%; load equal to ZERO for carriages type RAN

11) CM_x equal to ZERO on carriage, type RAN and RYN

12) CM_z valid for carriages type RCN, RAN and RYN

LONG CARRIAGE WITH 3, 4, 5 AND 6 WHEELS TYPE RCN, RAN AND RYN

Guide	Carriage	$C_y^{(13)}$ (N)	$C_z^{(14)}$ (N)	$CM_x^{(15)}$ (Nm)	$CM_y^{(14)}$ (Nm)	$CM_z^{(16)}$ (Nm)	
						Mzl	Mzr
LS 28	C4 RCN 28 100 A	2900	1300	13	32	165	55
	C4 RCN 28 100 B	2900	1300	13	32	55	165
	C5 RCN 28 125	4400	2100	19	65	162	162
	C6 RCN 28 150 A	4800	2400	21	87	286	165
	C6 RCN 28 150 B	4800	2400	21	87	165	286
LS 43	C4 RCN 43 150 A	8800	4100	64	149	726	244
	C4 RCN 43 150 B	8800	4100	64	149	244	726
	C5 RCN 43 190	13200	7300	96	341	740	740
	C6 RCN 43 230 A	14400	7800	105	438	1300	750
	C6 RCN 43 230 B	14400	7800	105	438	750	1300
LS 63	C4 RCN 63 235 A	18900	8000	166	465	2470	824
	C4 RCN 63 235 B	18900	8000	166	465	824	2470
	C5 RCN 63 290	42600	13400	249	974	2470	2470
	C6 RCN 63 345 A	31000	15100	271	1250	4210	2430
	C6 RCN 63 345 B	31000	15100	271	1250	2430	4210

13) C_y directed to load the concentric wheels, valid for carriage type RCN, RAN and RYN

14) For carriages type RYS the load is reduced by 50%; load equal to ZERO for carriages type RAN

15) CM_x equal to ZERO on carriage type RAN and RYN

16) CM_z valid for carriages type RCN, RAN and RYN

CALCULATION EXAMPLE:

platform with 4 carriages C3 RCS 43 170

The general arrangement is shown in the drawing below.

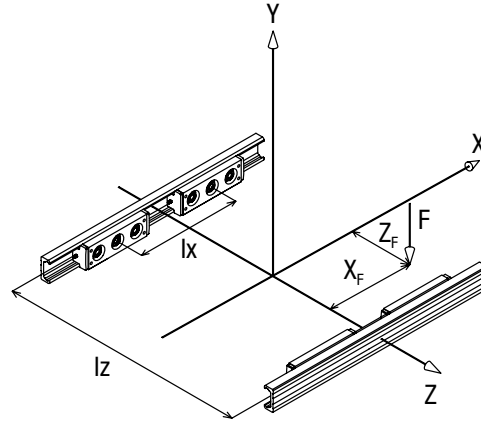

The platform runs along the two rails and is charged with load F which takes effect 100 mm and 50 mm afar from the middle of the carriage.

Data: guide LS 43; carriage C3 RCS 43 170

$l_x = 400 \text{ mm}$

$l_z = 300 \text{ mm}$

$F = 6000 \text{ N}$

$X_F = 100 \text{ mm}$

$Z_F = 50 \text{ mm}$

In this configuration P_y is the load on the mostly loaded carriage and is calculated as follows:

$$P = \frac{F}{4} + \frac{F \cdot X_F}{2 \cdot l_x} + \frac{F \cdot Z_F}{2 \cdot l_z} = 2750 \text{ N}$$

The load F_y indicated in the table of max. load for carriage C3 RCS 43 170 is 5500 N.

The system nominal lifetime is calculated as follows: from the table of the dynamic load capacity, the value C_y for carriage C3 RCS 43 170 is 13200 N.

$$L_{10} = (13200 / 2750)^3 \times 100 = 11059 \text{ km}$$

IMPORTANT REMARK

The rail must be lubricated to reach this value. Otherwise the expected lifetime can be reduced by fretting between rail and roller.

C-LINE

PRODUCT DESCRIPTION

SELF-ALIGNING SYSTEM

The combined use of “fixed” rollers type RCS and RCN with floating rollers type RAS and RAN allows to obtain a selfaligning system, in fact, floating rollers, where the bearing can slide axially on the stud, allow to recover any alignment error due to an inaccurate mounting or deformations.

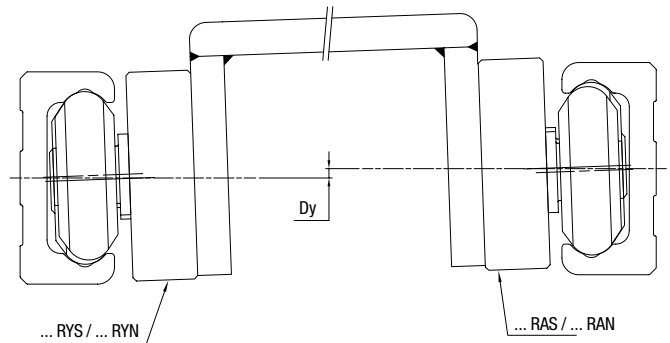
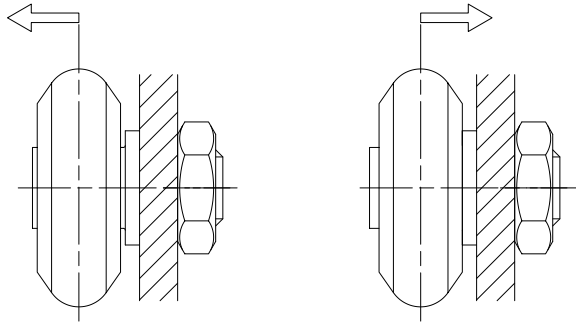

MAXIMUM MISALIGNMENT ALLOWED BY ALIGNING CARRIAGES RAS, RAN, RYS AND RYN

Guide	Carriage	α max.	S (mm)	H nominal (mm)
LS 28	C ... RAS 28 ...	1°	-0.5 / +1.2	24
	C ... RAN 28 ...			23.9
LS 43	C ... RAS 43 ...	1.5°	-0.8 / +1.5	37
	C ... RAN 43 ...			
LS 63	C ... RAS 63 ...	1°	-1 / +3	50.5
	C ... RAN 63 ...			49.8
LS 28	C ... RYS 28 ...	1°	-	24
	C ... RYN 28 ...			23.9
LS 43	C ... RYS 43 ...	1.5°	-	37
	C ... RYN 43 ...			
LS 63	C ... RYS 63 ...	1°	-	50.5
	C ... RYN 63 ...			49.8

HORIZONTAL MISALIGNMENT DX

In case of horizontal misalignment D_x between mounting surfaces, you can use on one side LS guides with carriages type RCS or RCN and, on the opposite parallel side, LS guides with floating carriages type RAS or RAN; carriages RAN and RAS allow an axial misalignment D_x .

Floating carriages can support radial forces only; the axial load, transverse to the running direction, will have to be supported entirely by the “fixed” carriage type RCS or RCN.

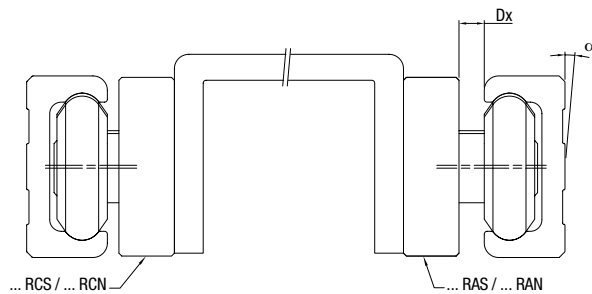

VERTICAL MISALIGNMENT DY

In the case of vertical misalignment D_y between the guides, you must allow rotation of both carriages; for this reason carriages type RYN and RYS are equipped with “fixed” rollers (RCS and RCN), in contact with a sliding track, and eccentric floating rollers (RASR and RANR) in contact with the opposite raceway. On the parallel guide, a carriage with only floating rollers type RAS or RAN must be mounted.

The maximum value of D_y depends on the distance between the guides and must not exceed the maximum angle α . provided for the carriage equals to $\alpha = 1.5^\circ$.

The axial load capacity of carriages RYS and RYN is halved compared to the carriages RCS and RCN of the same size.

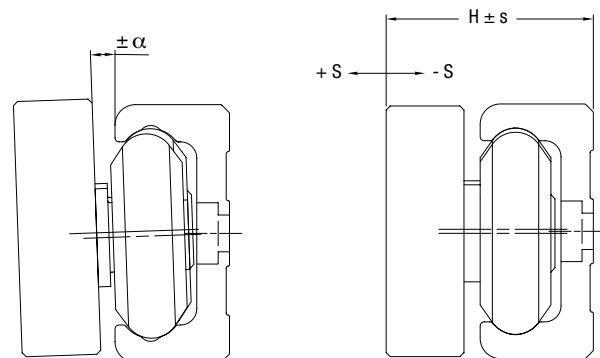

SCREW FOR RAILS WITH COUNTERBORE HOLES

Guides with counterbore holes come with complete set of shallow head screws DIN EN ISO 7380 (Class 10.9).

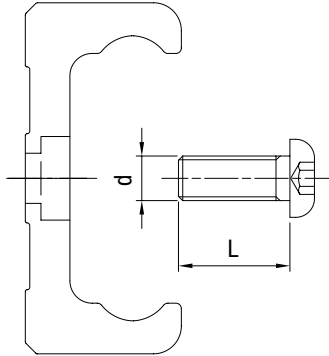

Guide	Screw diameter d	L	Torque wrench settings (Nm)
LS 28	M5 x 0.8	12	8
LS 43	M8 x 1.25	16	22
LS 63	M8 x 1.25	20	34

ALIGNMENT DEVICE ALS

For an easier mounting of two consecutive rails we recommend the use of alignment devices ALS.

Guide	Alignment device
LS 28	ALS 28
LS 43	ALS 43

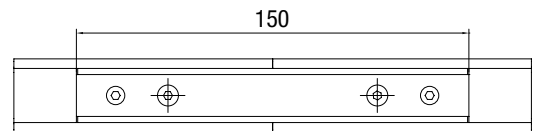
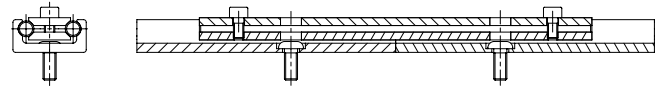

INSTRUCTIONS

- Insert the screws into the holes of the guide without tightening
- Mount the alignment device and tighten its screws until it reaches the proper alignment
- Tighten the screws of the guides

C-LINE

GUIDE RAILS LS

Rails totally in steel with internal hardened raceways.



HOLE PATTERN A: BORING FOR COUNTERBORE SCREWS ACCORDING TO DIN EN ISO 7380

LS 28

LS 43

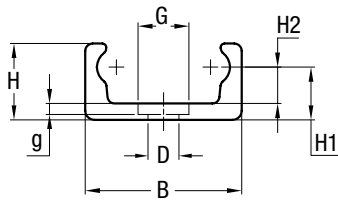

LS 63

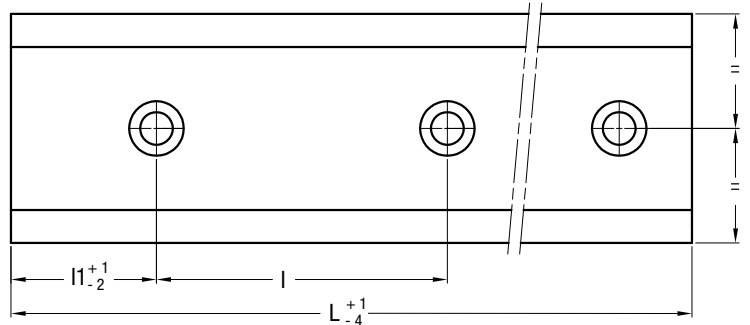
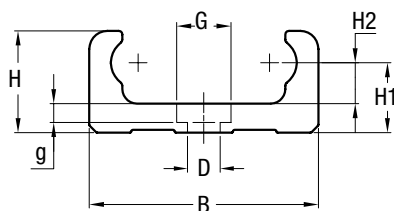

HOLE PATTERN B: BORING FOR COUNTERSUNK SCREWS ACCORDING TO EN ISO 10642.

LS 28

LS 43

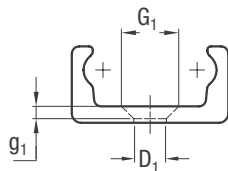

LS 63

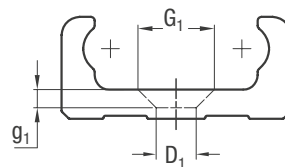

Type	Dimensions (mm)													Moment of inertia (cm ⁴)		Weight (kg/m)
	B	H	H1	H2	D	G	g	D ₁	G ₁	g ₁	l	l ₁	L max. 1)	J _x	J _y	
LS 28	28	12.5	9	5.5	6.6	11	2.1	5.5	10.6	2.6	80	40	4000	0.17	1.45	1.18
LS 43	43	21	14.5	10	9	15	2.5	9	17	4	80	40	4000	1.28	8.6	2.75
LS 63	63	28	19.25	11.25	9	15	4.5	11	21	5.5	80	40	4000	4.5	38.9	6.22

1) Longer rails will be fitted with finish-machined joints

RAIL DESIGN STANDARD

- Drawn, induction hardened raceways (MT)
- Surface zinc-plated (MT ... GZ)

FIXING HOLES

- Hole pattern according to catalogue (A or B)
- Hole pattern according to drawing (NZ)
- Without holes (NF)

SURFACE OPTIONS

- Chemically nickel-plated (NW)
- Uncoated, blasted

Example standard type: LS 43 MT 2480 AGZ
Screws DIN EN ISO 7380 (10.9) are included in delivery.

GUIDE ROLLERS RCS

Guide rollers with balls for LS guide.



CONCENTRIC

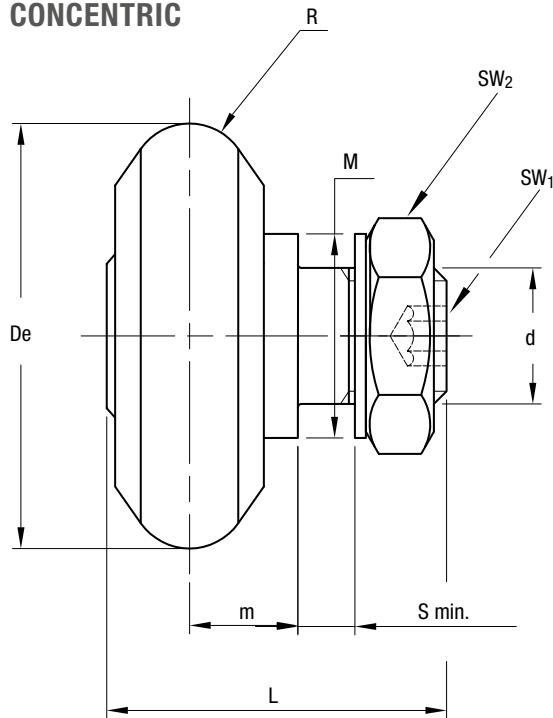

ECCENTRIC

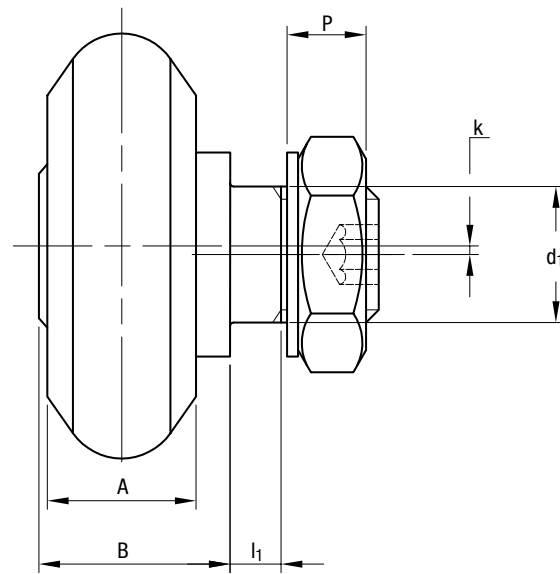

Type		Dimensions (mm)															Guide
concentric	eccentric	De	R	d ₁ ¹⁾	d	m	S min.	P	L	A	B	l ₁	M	SW ₁	SW ₂	k	
RCS 28	RCSR 28	23.5	3	8	M8	6	2.5	4.8	18.5	6	10	3.5	12	3	13	0.5	LS 28
RCS 43	RCSR 43	35.5	5	10	M10 x 1.25	9	4.5	6	27.5	11	15	5.5	17.5	4	16	0.75	LS 43
RCS 63	RCSR 63	50	7	16	M16 x 1.5	12.75	5.25	9.2	39.5	17	22.25	6.25	24	6	24	1	LS 63

1) Tolerance of mounting hole: H7

Type		Dynamic load (N)	Limit loads (N)		Life coefficients		Torque wrench settings ³⁾ (Nm)	Weight (g)
concentric	eccentric		C _w ²⁾	Radial F _r	Axial F _a	X		
RCS 28	RCSR 28	2200	1200	330	1	2.7	8	25
RCS 43	RCSR 43	6600	2750	850	1	2.2	20	80
RCS 63	RCSR 63	14200	6500	2200	1	2.8	64	255

2) C_w = load for lifetime of 100 km

3) The tightening torques apply to non-lubricated threads; for lubricated threads the values have to be multiplied by 0.8

- Guide rollers will be supplied with washers and nuts (DIN 439B)
- Contact angle α for the load calculation: 55°
- Standard seals type RS.

C-LINE

FLOATING GUIDE ROLLERS RAS

Floating guide rollers with balls.



CONCENTRIC

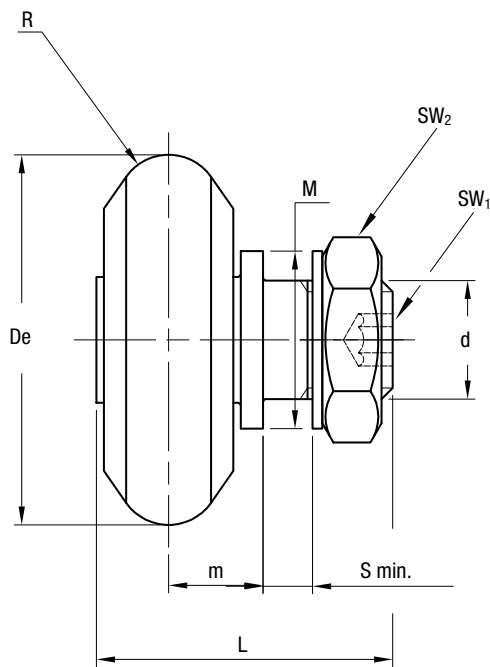

ECCENTRIC

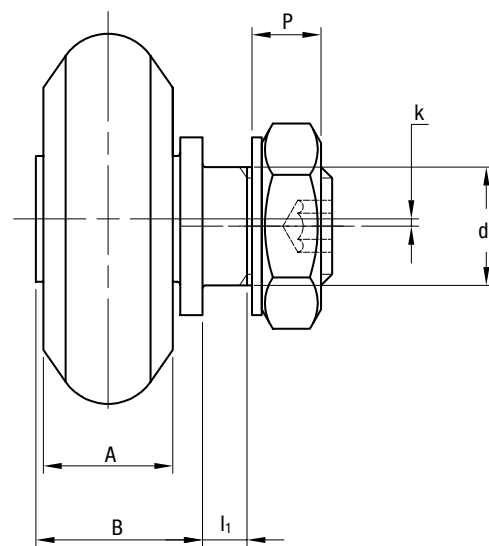

Type		Dimensions (mm)																Guide
concentric	eccentric	De	R	d ₁ ¹⁾	d	m min. ²⁾	m max. ²⁾	S min.	P	L	A	B	I ₁	M	SW ₁	SW ₂	k	
RAS 28	RASR 28	23.5	3	8	M8	5.5	7.2	2.5	4.7	18	6	9.5	3.5	12	3	13	0.5	LS 28
RAS 43	RASR 43	35.5	5	10	M10 x 1.25	8.2	10.5	4.5	5.9	27	10	14.5	5.5	17.5	4	16	0.75	LS 43
RAS 63	RASR 63	50	7	16	M16 x 1.5	11.75	15.75	5.5	9.2	40	17	22.5	6.5	24	6	24	1	LS 63

1) Tolerance of mounting hole: H7

2) Maximum displacement of dimension m to ensure proper guide roller function and safety

Type		Dynamic load (N)	Limit loads (N)	Torque wrench settings ⁴⁾ (Nm)	Weight (g)
concentric	eccentric	C _w ³⁾	Radial F _r		
RAS 28	RASR 28	2200	1200	8	25
RAS 43	RASR 43	6600	2750	20	80
RAS 63	RASR 63	14200	6500	64	255

3) C_w = load for lifetime of 100 km

4) The tightening torques apply to non-lubricated threads; for lubricated threads the values have to be multiplied by 0.8

- Guide rollers will be supplied with washers and nuts (DIN 439B)
- Contact angle α for the load calculation: 55°
- Standard seals type RS

GUIDE ROLLERS RCN

Guide rollers with balls for LS guide.



CONCENTRIC

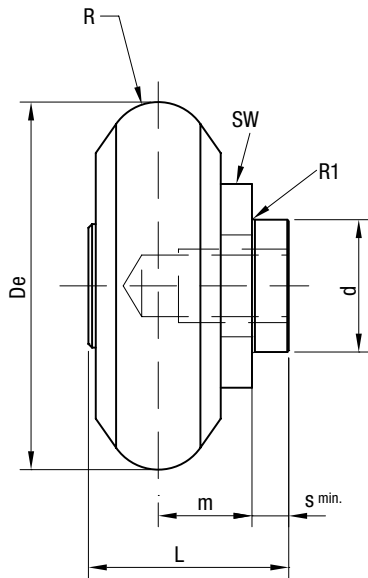

ECCENTRIC

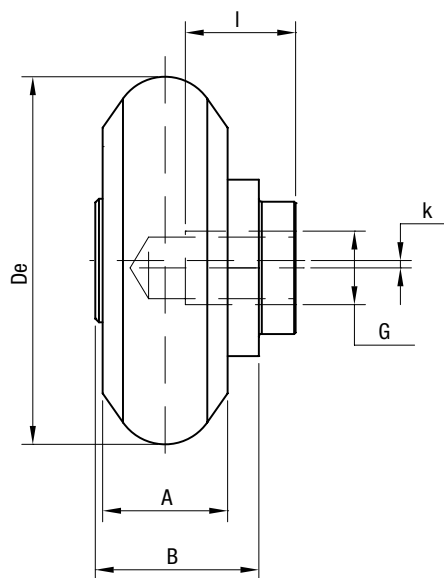

Type		Dimensions (mm)													Weight (g)	Guide
concentric	eccentric	De	R	d ¹⁾	m	R1 max.	S	L	A	B	SW	G	I	k		
RCN 28	RCNR 28	23.5	3	10	6	0.4	2	11.7	6	9.7	13	M5	8	0.5	22	LS 28
RCN 43	RCNR 43	35.5	5	12	9	0.4	3	17.9	10	14.9	17	M8	11	0.75	76	LS 43
RCN 63	RCNR 63	50	7	18	12.75	0.4	5	27.25	17	22.25	24	M10	15	1	237	LS 63

1) Tolerance of mounting hole: H7

Type		Dynamic load (N)	Limit loads (N)		Life coefficients		Screw diameter G	Screw length (mm)	Torque wrench settings ³⁾ (Nm)
concentric	eccentric	C _w ²⁾	Radial F _r	Axial F _a	X	Y			
RCN 28	RCNR 28	2200	1200	330	1	2.7	M5	10	7
RCN 43	RCNR 43	6600	2750	850	1	2.2	M8	14	12
RCN 63	RCNR 63	14200	6500	2200	1	2.8	M10	20	35

2) C_w = load for lifetime of 100 km

3) The tightening torques apply to non-lubricated threads; for lubricated threads the values have to be multiplied by 0.8

- Screws type (10.9); the use of self-locking safety washers is recommended
- Contact angle α for the load calculation: 55°
- Standard seals type RS

C-LINE

GUIDE ROLLERS RAN

Floating guide rollers with balls.



CONCENTRIC

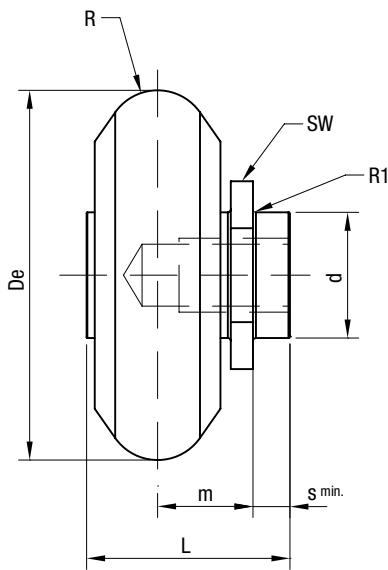

ECCENTRIC

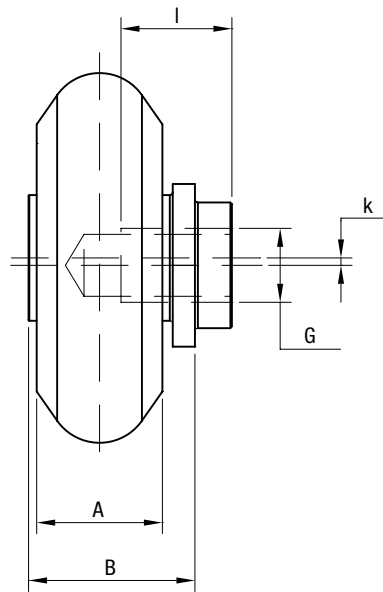

Type		Dimensions (mm)														Weight (g)	Guide
concentric	eccentric	De	R	d ¹⁾	m min. ²⁾	m max. ²⁾	R1 max.	S	L	A	B	SW	G	I	k		
RAN 28	RANR 28	23.5	3	10	5.4	7.1	0.4	2	11.4	6	9.4	13	M5	8	0.5	22	LS 28
RAN 43	RANR 43	35.5	5	12	7.8	10.1	0.4	3	18.1	10	15.1	17	M8	11	0.75	76	LS 43
RAN 63	RANR 63	50	7	18	11.7	15.7	0.4	5	27.5	17	22.5	24	M10	15	1	237	LS 63

1) Tolerance of mounting hole: H7

2) Maximum displacement of dimension m to ensure proper guide roller function and safety

Type		Dynamic load (N)	Limit loads (N)	Screw diameter G	Screw length (mm)	Torque wrench settings ⁴⁾ (Nm)
concentric	eccentric	C _w ³⁾	Radial F _r			
RAN 28	RANR 28	2200	1200	M5	10	7
RAN 43	RANR 43	6600	2750	M8	14	12
RAN 63	RANR 63	14200	6500	M10	20	35

3) C_w = load for lifetime of 100 km

4) The tightening torques apply to non-lubricated threads; for lubricated threads the values have to be multiplied by 0.8

- Screws type (10.9); the use of self-locking safety washers is recommended
- Contact angle α for load calculation: 55°
- Standard seals type RS

CARRIAGES C3 RCS, C3 RAS, C3 RYS

Carriages with body in anodised aluminium with 3 guide rollers.

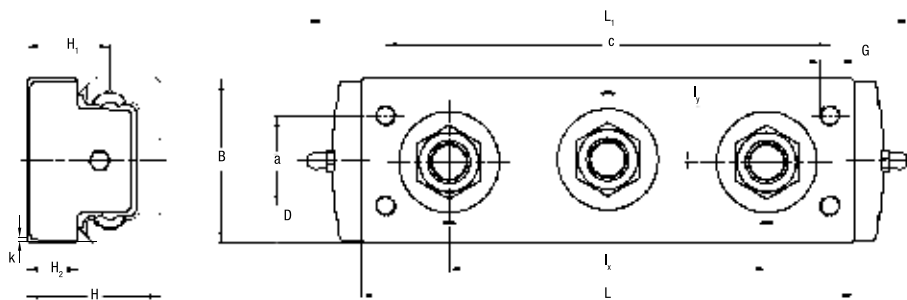

SHORT CARRIAGE

Type	Dimensions (mm)													Weight (kg)	Guide
	L	L ₁	B	l _x	l _y	H	H ₁	H ₂	G	a	b	c	k		
C3 RCS 28 126	88	126	26.5	50	0.5	24	15	9	M5 (2x)	–	13.25	78	0.75	0.13	LS 28
C3 RCS 43 170	130	170	40	78	1	37	22.5	13.5	M8 (2x)	–	20	114	1.5	0.44	LS 43
C3 RCS 63 226	186	226	60	120	1	50.5	31.25	18.5	M8 (4x)	34	13	168	1.5	1.2	LS 63

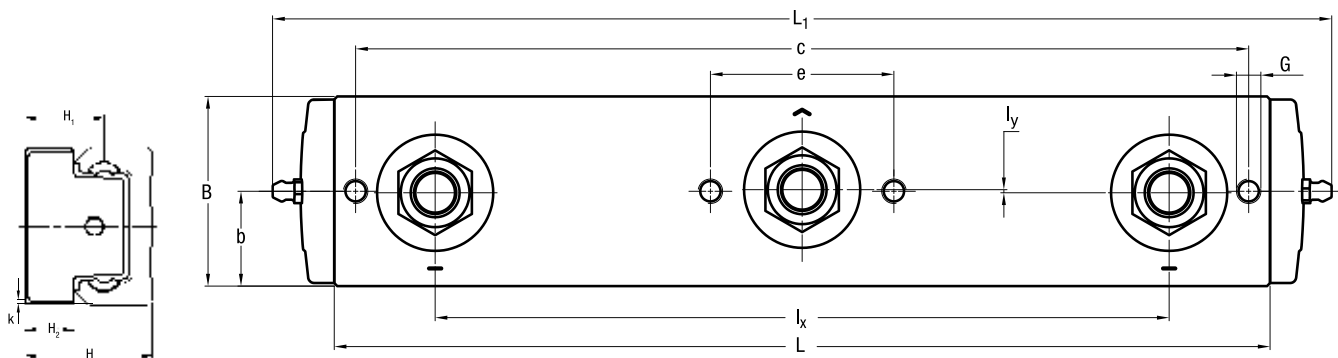

LONG CARRIAGE

Type	Dimensions (mm)													Weight (kg)	Guide
	L	L ₁	B	l _x	l _y	H	H ₁	H ₂	G	b	c	e	k		
C3 RCS 28 178 A	140	178	26.5	104	0.5	24	15	9	M5	13.25	130	26	0.75	0.15	LS 28
C3 RCS 43 245 A	205	245	41	152	1	37	22.5	13.5	M8	20.5	188	37	1	0.50	LS 43

- Dimensions also apply to C3 RAS and C3 RYS
- The markings show the contact points with the running surface of the rails

C-LINE

CARRIAGES C4 RCS, C4 RAS, C4 RYS

Carriages with body in anodised aluminium with 4 guide rollers.

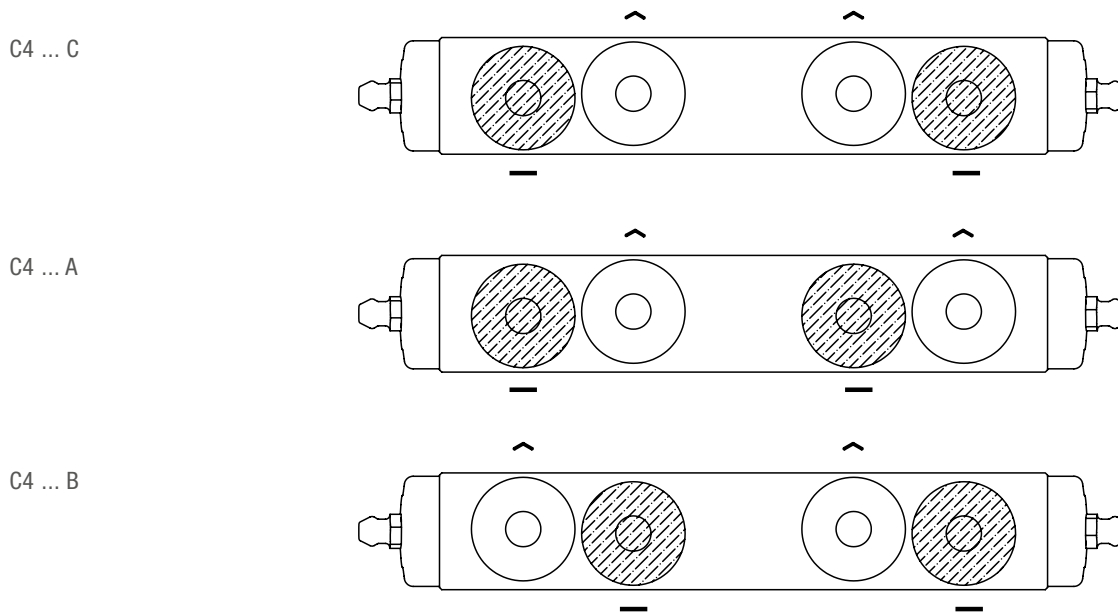

Standard roller combinations
The markings show the contact points with the running surface of the rails

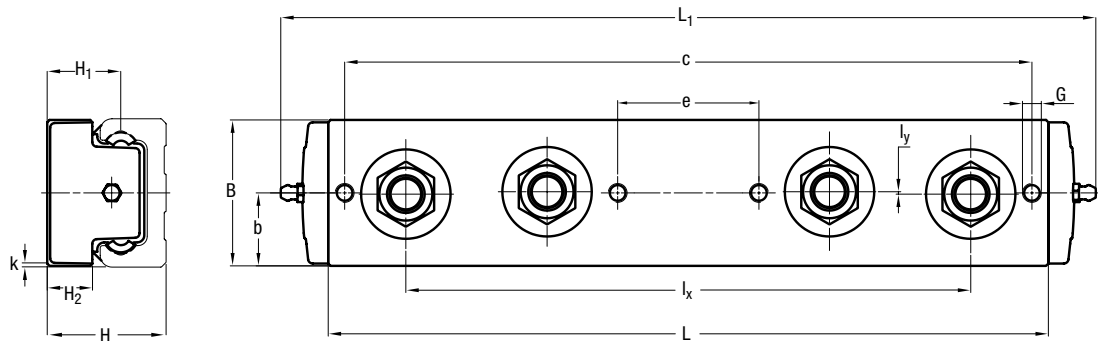

Type	Dimensions (mm)													Weight (kg)	Guide
	L	L ₁	B	l _x	l _y	H	H ₁	H ₂	G	b	c	e	k		
C4 RCS 28 178 C	140	178	26.5	104	0.5	24	15	9	M5	13.25	130	26	0.75	0.23	LS28
C4 RCS 28 178 A															
C4 RCS 28 178 B															
C4 RCS 43 245 C	205	245	41	152	1	37	22.5	13.5	M8	20.5	188	37	1	0.58	LS43
C4 RCS 43 245 A															
C4 RCS 43 245 B															

- Dimensions also apply to C4 RAS C / A / B and C4 RYS C / A / B

CARRIAGES C5 RCS, C5 RAS, C5 RYS

Carriages with body in anodised aluminium with 5 guide rollers.



C5 ... A

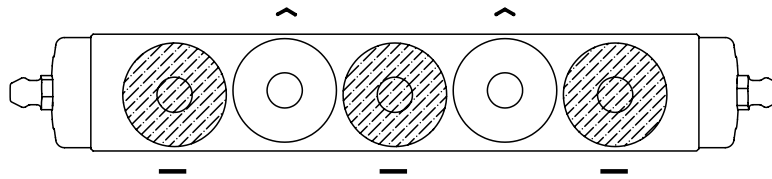

C5 ... B

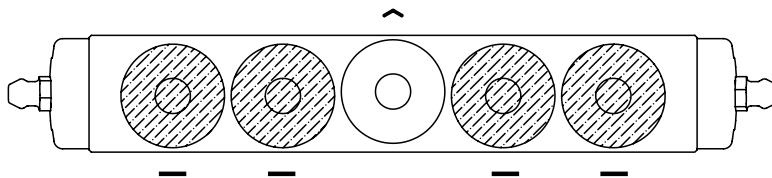

Standard roller combinations

The markings show the contact points with the running surface of the rails

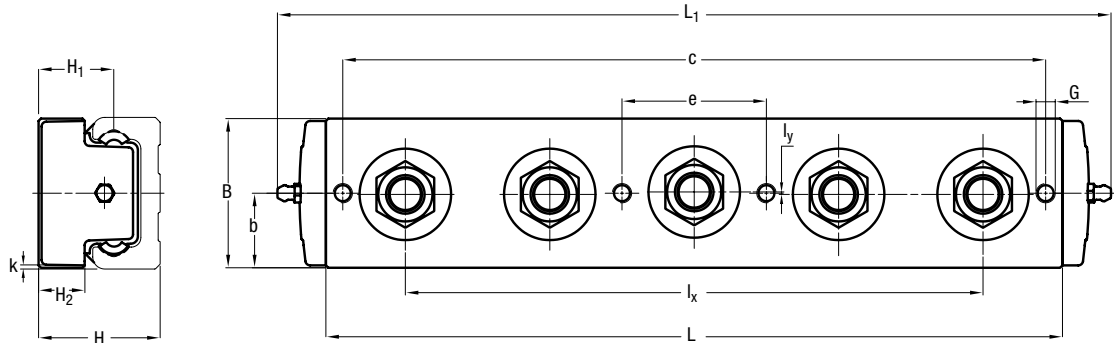

Type	Dimensions (mm)													Weight (kg)	Guide
	L	L ₁	B	l _x	l _y	H	H ₁	H ₂	G	b	c	e	k		
C5 RCS 28 178 A C5 RCS 28 178 B	140	178	26.5	104	0.5	24	15	9	M5	13.25	130	26	0.75	0.25	LS 28
C5 RCS 43 245 A C5 RCS 43 245 B	205	245	41	152	1	37	22.5	13.5	M8	20.5	188	37	1	0.66	LS 43

- Dimensions also apply to C5 RAS A / B and C5 RYS A / B

C-LINE

CARRIAGES C3 RCN, C3 RAN, C3 RYN

Carriages with steel body with 3 guide rollers for LS guides.

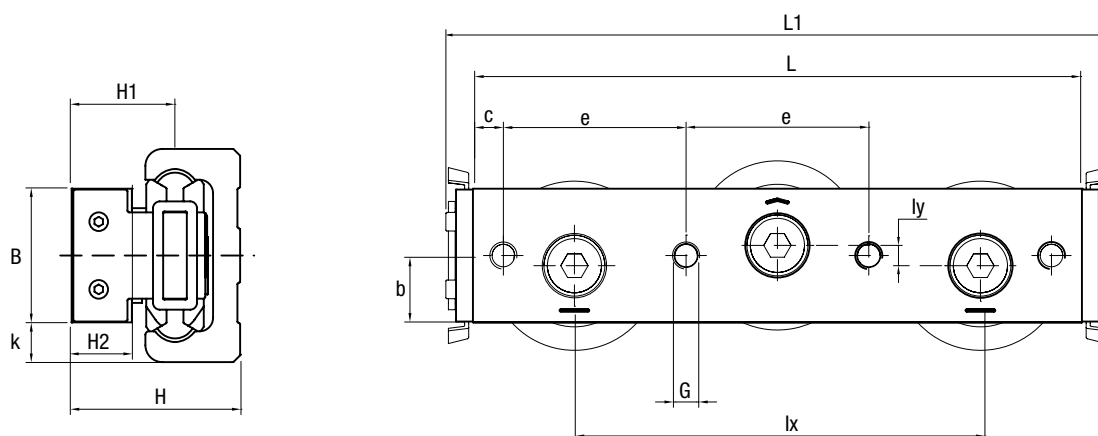
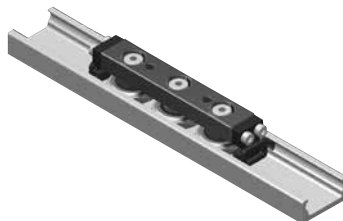

Type	Dimensions (mm)													Weight (kg)	Guide
	L	L1	B	lx	ly	H	H1	H2	G	b	c	e	k		
C3 RCN 28 080	80	96	14.9	54	0.5	23.9	14.9	8.9	M5 (2 x)	7.45	22.5	35	6.55	0.145	LS 28
C3 RCN 43 120	120	136	24.9	80	0,75	37	22.5	13.5	M8 (2 x)	12.45	32.5	55	9.05	0.534	LS 43
C3 RCN 63 180	180	196	39.5	120	1	49.8	30.55	17.8	M8 (4 x)	19.75	9	54	6.75	1.666	LS 63

- Dimensions also apply to C3 RAN and C3 RYN
- The markings show the contact points with the running surface of the rails

CARRIAGES C4 RCN, C4 RAN, C4 RYN

Carriages with steel body with 4 guide rollers for LS guides.

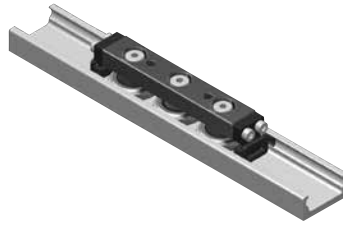

C4 ... A

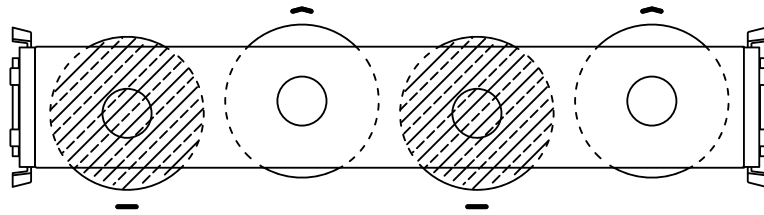

C4 ... B

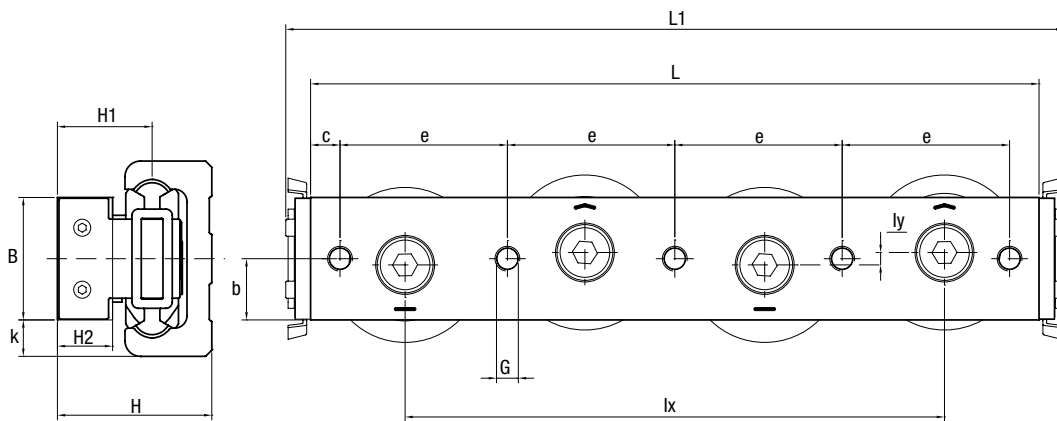
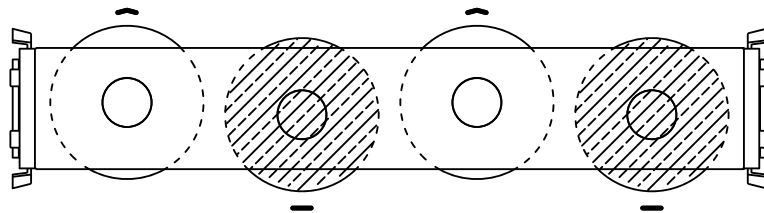

Type	Dimensions (mm)													Weight (kg)	Guide
	L	L1	B	lx	ly	H	H1	H2	G	b	c	e	k		
C4 RCN 28 100 A C4 RCN 28 100 B	100	116	14.9	75	0.5	23.9	14.9	8.9	M5 (2 x)	7.45	25	50	6.55	0.18	LS 28
C4 RCN 43 150 A C4 RCN 43 150 B	150	166	24.9	110	0,75	37	22.5	13.5	M8 (2 x)	12.45	35	80	9.05	0.684	LS 43
C4 RCN 63 235 A C4 RCN 63 235 B	235	251	39.5	174	1	49.8	30.55	17.8	M8 (5 x)	19.75	9.5	54	6.75	2.149	LS 63

- Dimensions also apply to C4 RAN and C4 RYN
- The markings show the contact points with the running surface of the rails

C-LINE

CARRIAGES C5 RCN, C5 RAN, C5 RYN

Carriages with steel body with 5 guide rollers for LS guides.

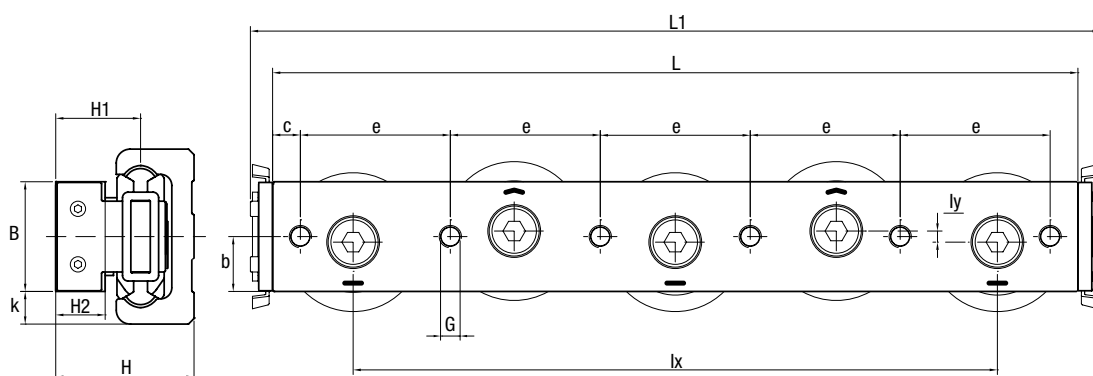
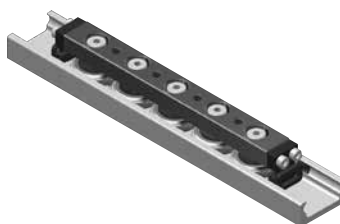

Type	Dimensions (mm)													Weight (kg)	Guide
	L	L1	B	lx	ly	H	H1	H2	G	b	c	e	k		
C5 RCN 28 125	125	141	14.9	98	0.5	23.9	14.9	8.9	M5 (4 x)	7.45	25	25	6.55	0.229	LS 28
C5 RCN 43 190	190	206	24.9	150	0,75	37	22.5	13.5	M8 (4 x)	12.45	35	40	9.05	0.853	LS 43
C5 RCN 63 290	290	306	39.5	232	1	49.8	30.55	17.8	M8 (6 x)	19.75	10	54	6.75	2.672	LS 28

- Dimensions also apply to C5 RAN and C5 RYN
- The markings show the contact points with the running surface of the rails

CARRIAGES C6 RCN, C6 RAN, C6 RYN

Carriages with steel body with 6 guide rollers for LS guides.

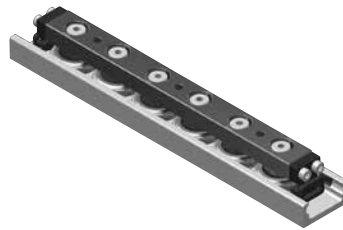

C6 ... A

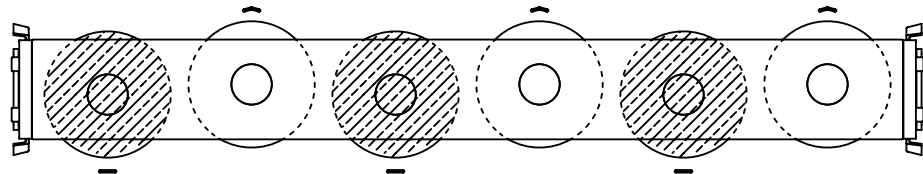

C6 ... B

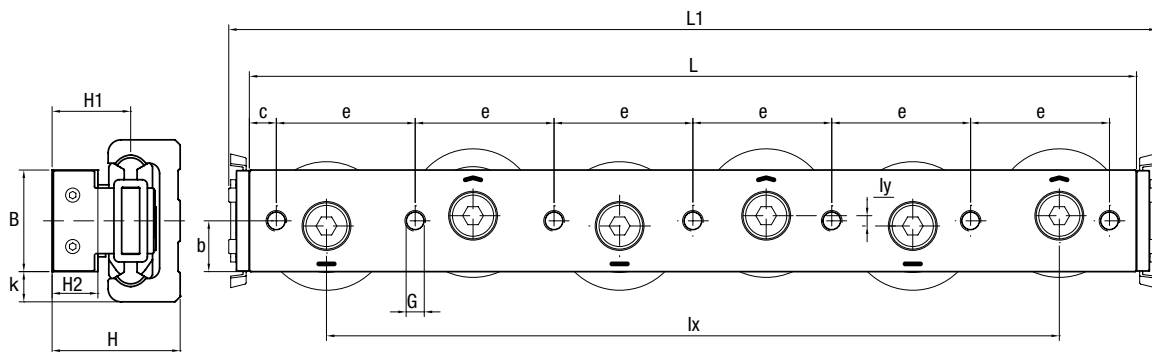
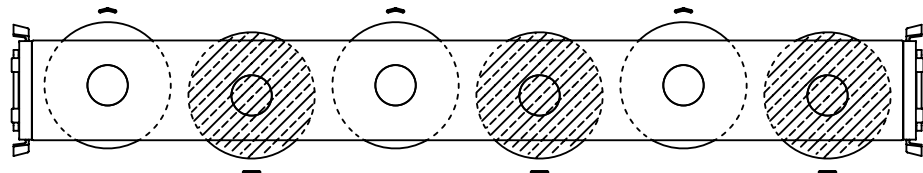

Type	Dimensions (mm)													Weight (kg)	Guide
	L	L1	B	lx	ly	H	H1	H2	G	b	c	e	k		
C6 RCN 28 150 A C6 RCN 28 150 B	150	166	14.9	125	0.5	23.9	14.9	8.9	M5 (3 x)	7.45	25	50	6.55	0.265	LS 28
C6 RCN 43 230 A C6 RCN 43 230 B	230	246	24.9	190	0,75	37	22.5	13.5	M8 (3 x)	12.45	35	80	9.05	1.036	LS 43
C6 RCN 63 345 A C6 RCN 63 345 B	345	361	39.5	285	1	49.8	30.55	17.8	M8 (7 x)	19.75	10.5	54	6.75	3.158	LS 63

- Dimensions also apply to C6 RAN and C6 RYN
- The markings show the contact points with the running surface of the rails



BASE-LINE



PAGE 104

8.1 PRODUCT DESCRIPTION – DC-, C-SYSTEM

PAGE 105

8.2 DC-, C-SYSTEM

For medium loads

- Guide rails DC
- Guide rails C
- Guide rollers PFV with “gothic arch” profile
- Guide rollers PFV
- Guide rollers RKO
- Carriages T4 PFV
- Wiper NAID
- Lubricator LUBC

PAGE 114

8.3 FWS, FWH SYSTEM

For medium loads

- Guide rails FWS
- Guide rails FWH
- Guide rollers FR ... EU
- Guide rollers FR ... EU AS, FR ... EU AZ
- Floating guide rollers FRL ... EU
- Carriage T4FR

PAGE 120

8.4 GUIDE ROLLERS COMBINATION

PAGE 121

8.5 MOUNTING EXAMPLES

BASE-LINE PRODUCT DESCRIPTION – DC-, C-SYSTEM

KEY BENEFITS

- For light and medium loads
- Low and space-saving design
- Guide rails with stainless steel shafts
- Carriage with stainless guide rollers



DC system is based on rails, guide rollers and carriages that provide a complete guiding system. Rails and rollers can be used as single elements. In most cases the application is based on standard carriages.

The load capacities are tabulated with reference to the axis system shown in the sketch below:

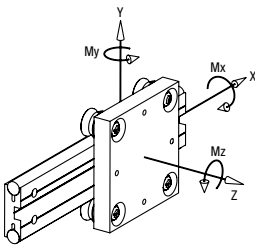

Rails	Carriage	Cy (N)	Cz (N)	CMx (Nm)	CMy (Nm)	CMz (Nm)
DC 10.54	T4 PFV 25 10 80	3700	1200	32	27	84
	T4 PFV 25 10 120	3700	1200	32	51	158
DC 16.80	T4 PFV 35 16 165	9000	2950	115	185	570
	T4 PFV 35 16 250	9000	2950	115	310	950
DC 18.65	T4 PFV 35 18 150	9000	2950	95	165	510
	T4 PFV 35 18 250	9000	2950	95	315	970
DC 25.95	T4 PFV 50 25 220	17500	6100	290	500	1400
	T4 PFV 50 25 300	17500	6100	290	750	2150

MAXIMUM LOADS ON SINGLE CARRIAGE

The following table shows the maximum loads that can be applied on a single carriage.

Rails	Carriage	Fy (N)	Fz (N)	Mx (Nm)	My (Nm)	Mz (Nm)
DC 10.54	T4 PFV 25 10 80	1590	800	22	18	35
	T4 PFV 25 10 120	1590	800	22	33	67
DC 16.80	T4 PFV 35 16 165	3000	1400	58	92	198
	T4 PFV 35 16 250	3000	1400	58	155	333
DC 18.65	T4 PFV 35 18 150	3000	1400	47	83	178
	T4 PFV 35 18 250	3000	1400	47	155	336
DC 25.95	T4 PFV 50 25 220	7890	3900	180	320	640
	T4 PFV 50 25 300	7890	3900	180	480	950

The maximum loads are based on the stud and bearing strengths and on a maximum contact pressure, between rail and roller, of 1250 N/mm². The loads in the table are considered as acting singularly. For applications with many loads acting at the same time the loads must be reduced.

BASIC DYNAMIC LOADS OF SINGLE CARRIAGE

The following table shows the nominal loads that correspond to a nominal life of the bearing at 100 km.

The nominal lifetime of the carriage can be estimated from the standard bearing formula

$$L_{10} = (C_i / P_i)^3 \times 100 \text{ km}$$

C_i is the basic dynamic load capacity in a specific direction i and P_i is the external load applied in the same specific direction.

CALCULATION EXAMPLE:

CARRIAGE LOADED WITH AN EXTERNAL LOAD F

Carriage T4 PFV 50 25 220

F = 2000 N

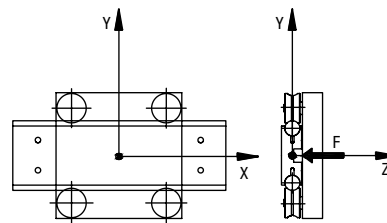

The external load F acts in the z-axis direction:

$$P_z = F = 2000 \text{ N}$$

In the table of the “maximum loads” you find that the load capacity F_z for carriage T4 PFV 50 25 220 is equal to 3900 N, so the system is validated against breakage. To estimate the system lifetime we proceed as follows: from the table of the “basic dynamic loads” we see that C_z, for the carriage T4 PFV 50 25 220, is equal to 6100 N.

The nominal lifetime will be:

$$L_{10} = (6100 / 2000)^3 \times 100 = 2837 \text{ km}$$

IMPORTANT REMARK

- In order to reach the calculated lifetime it is important to lubricate the rails.
- For load configurations with many loads and moments acting at the same time in different directions, please refer to the calculation examples you can find at the end of the catalogue or contact our technical department.

BASE-LINE – DC-, C-SYSTEMS

GUIDE RAILS DC

8.2

Rail composed by an aluminium body and two shafts in steel, with two raceways.

Available in stainless steel version.



DC 16.80
DC 18.65
DC 10.54

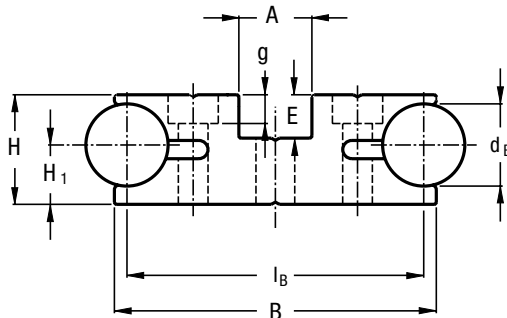

DC 25.95

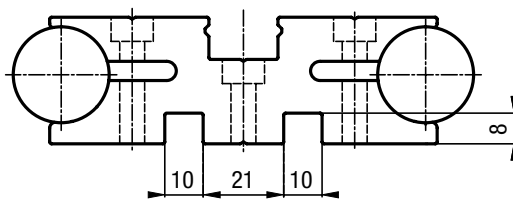

DC...S

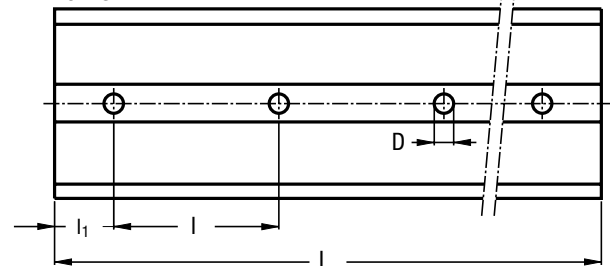

DC...D

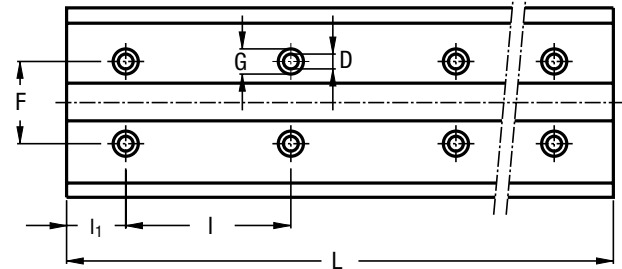

Type	Dimensions (mm)													Moments of inertia ²⁾ (cm ⁴)		Weight (kg/m)
	dB	lB	B	H	H ₁	A	E	D	G	g	F	l	l ₁	J _x	J _y	
DC 10.54 S ¹⁾	10	54	57	19.5	13	25	10.5	6.5	–	–	–	150	30	2.16	20.5	3.15
DC 10.54 D ¹⁾	10	54	57	19.5	13	25	10.5	4.4	8	4.2	36	150	30	2.16	20.5	3.15
DC 16.80 S ¹⁾	16	80	86	25.5	14.5	18	9.5	8.5	–	–	–	150	30	9.6	85	7.1
DC 16.80 D ¹⁾	16	80	86	25.5	14.5	18	9.5	6.5	11	6.3	54	150	30	9.6	85	7.1
DC 18.65 S	18	65	70.5	24	13	16	9.5	8.5	–	–	–	150	30	6.1	34.7	7
DC 18.65 D	18	65	70.5	24	13	16	9.5	6.5	11	6.3	36	150	30	6.1	34.7	7
DC 25.95 S ¹⁾	25	95	101	33	18	19	13	10.5	–	–	–	150	30	21.8	142.2	13.5
DC 25.95 D ¹⁾	25	95	101	33	18	19	13	6.5	11	6.3	58	150	30	21.8	142.2	13.53

Max. length in single element L = 6000 mm.

Longer rails are supplied in sections with ground butt joints and, on request, with pin connection

1) Available with stainless steel shafts

2) Inertia value based on equivalent aluminium yield 70000 N/mm²

HOLE LAYOUT

- Holes according to catalogue (S or D)
- Finishes to drawing (NZ)
- Without holes (NF)

OPTIONAL FEATURES

- Ground one end: side of the first hole (1R), side of the last hole (2R)
- Ground both ends (RR)
- Stainless steel shafts (NX)
- Chromium plated shafts (CH)
- Pin based shaft connection (G)

Example of standard designation: DC 2595 S 2010 NX.

BASE-LINE – DC-, C-SYSTEMS

GUIDE RAILS C

Rail composed by an aluminium body and one shaft in steel, with a single raceway.

Available in stainless steel version.

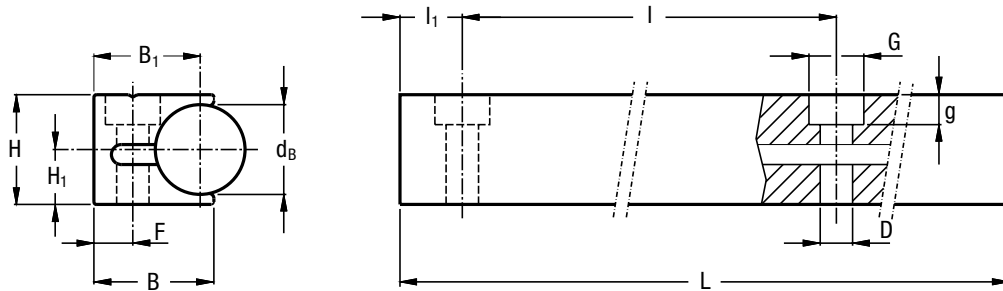

Type	Dimensions (mm)											Moments of inertia ²⁾ (cm ⁴)		Weight (kg/m)
	d _B	B	B ₁	H	H ₁	D	G	g	F	l	l ₁	J _x	J _y	
C 10 ¹⁾	10	16.9	15.4	14.5	8	4.4	8	4.2	6.5	100	30	0.4	0.3	1.1
C 18	18	24	21.3	22	11	6.5	11	6.3	7.8	150	50	1.7	1.1	2.8
C 22	22	28	25	26.5	13.5	6.5	11	6.3	9	160	50	3.5	2	4.1
C 30 ¹⁾	30	36	32.5	36	19	9	15	8.3	11.5	180	60	11.1	5.6	7.6

Max. length in single element L = 6000 mm.

Longer rails are supplied in sections with ground butt joints and, on request, with pin connection

1) Available with stainless steel shafts

2) Inertia value based on equivalent aluminium yield 70000 N/mm²

HOLE LAYOUT

- Holes according to catalogue (SB)
- Finishes to drawing (NZ)
- Without holes (NF)

OPTIONAL FEATURES

- Ground one end: side of the first hole (1R), side of the last hole (2R)
- Ground both ends (RR)
- Stainless steel shafts (NX)
- Chromium plated shafts (CH)
- Pin based shaft connection (G)

Example of standard designation: C 10 2060 SB.

GUIDE ROLLERS PFV WITH "GOTHIC ARCH" PROFILE

Guide roller with "gothic arch" profile, based on ball bearings.

Available in stainless steel version.



CONCENTRIC

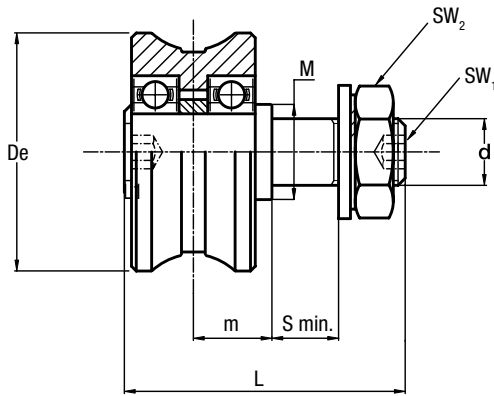

ECCENTRIC

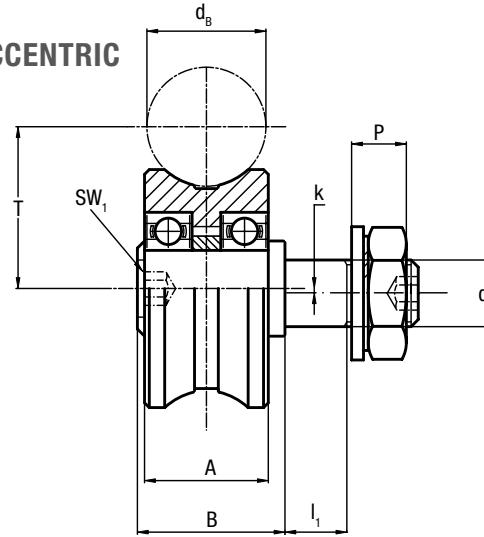

Type		Dimensions (mm)															Recommended pairings	
concentric	eccentric	De	db	d ₁ ²⁾	d	T	m	S min.	P	L	A	B	l ₁	M	SW ₁	SW ₂		k
PFV 25.10 ¹⁾	PFVR 25.10 ¹⁾	25	10	8	M8x1.25	15.5	7.5	11	9	34.8	12	14.8	10	12	4	13	0.75	C 10, DC 10.54
PFV 35.16 ¹⁾	PFVR 35.16 ¹⁾	35	16	10	M10x1.25	23	12	12	10.7	45.3	18	22.3	11	15	4	17	0.75	DC 16.80
PFV 35.18 ¹⁾	PFVR 35.18 ¹⁾	35	18	10	M10x1.25	24	12	12	10.7	45.3	18	22.3	11	15	4	17	0.75	C 18, DC 18.65
PFV 43.22 ¹⁾	PFVR 43.22 ¹⁾	43	22	12	M12x1.5	29	14	13	12.5	52	23	27	12	18	5	19	1	C 22
PFV 50.25 ¹⁾	PFVR 50.25 ¹⁾	50	25	14	M14x1.5	34	16.5	14	13.5	59	26	31	13	20	6	22	1	DC 25.95
PFV 60.30	PFVR 60.30	60	30	16	M16x1.5	41	19.5	17	14	69.5	31	36.5	16	30	8	24	1	C 30

1) Available in stainless steel (suffix NX)

2) Housing bore tolerance: H7

Type		Dynamic load (N)	Limit loads (N)		Life coefficients		Torque wrench settings ⁴⁾ (Nm)	Weight (g)
concentric	eccentric	C _w ³⁾	Radial F _r	Axial F _a	X	Y		
PFV 25.10	PFVR 25.10	1850	1080	200	1	4.4	8	42
PFV 35.16	PFVR 35.16	4550	1500	350	1	4.4	20	115
PFV 35.18	PFVR 35.18	4550	1500	350	1	4.4	20	113
PFV 43.22	PFVR 43.22	7600	3150	750	1	4	26	210
PFV 50.25	PFVR 50.25	8800	4240	940	1	4	44	335
PFV 60.30	PFVR 60.30	15700	5360	1350	1	4.3	64	570

3) C_w basic load for 100 km

4) The torque wrench settings are given for non-lubricated threads; for lubricated threads, multiply figure by 0.8

- The guide rollers are complete with self-locking washers and hexagonal nut (DIN 439B) for fitting

- Pressure angle α for load calculation: 60°
- NBR seals, RS type.

GUIDE ROLLERS PFV

Guide roller based on ball bearings.

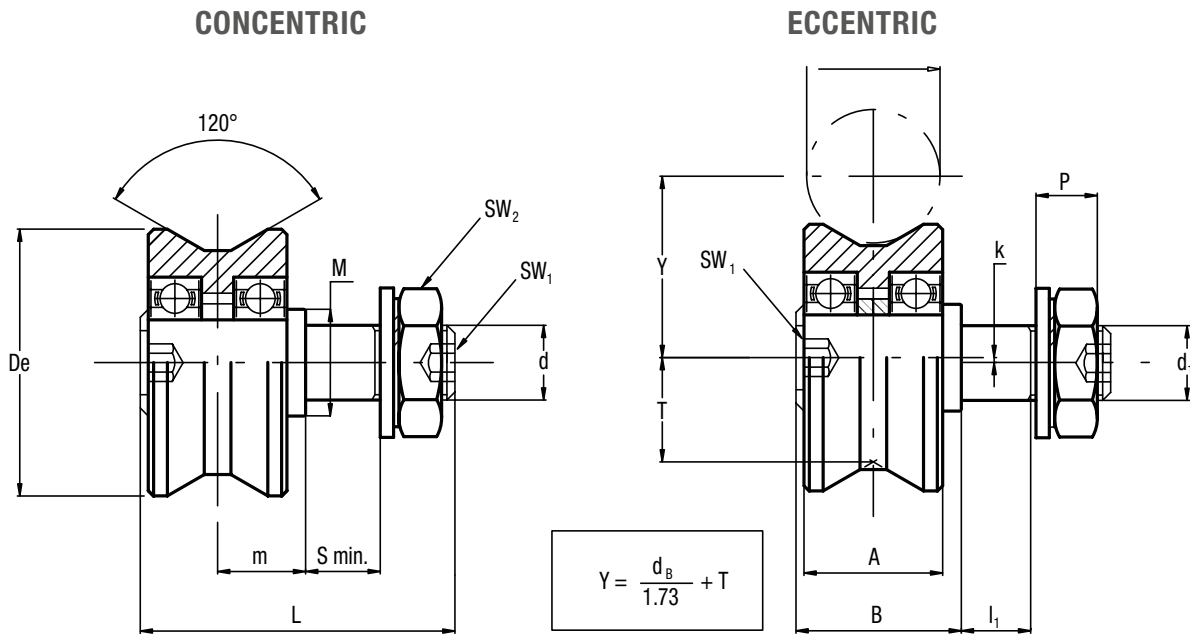

Type		Dimensions (mm)															
concentric	eccentric	De	db	d ₁ ¹⁾	d	T	m	S min.	P	L	A	B	I ₁	M	SW ₁	SW ₂	k
PFV 25	PFVR 25	25	da 6 a 18	8	M8x1.25	9.7	7.5	11	9	34.8	12	14.8	10	12	4	13	0.75
PFV 35	PFVR 35	35	da 14 a 25	10	M10x1.25	13.6	12	12	10.7	45.3	18	22.3	11	15	4	17	0.75
PFV 43	PFVR 43	43	da 18 a 30	12	M12x1.5	16.3	14	13	12.5	52	23	27	12	18	5	19	1
PFV 50	PFVR 50	50	da 20 a 35	14	M14x1.5	19.6	16.5	14	13.5	59	26	31	13	20	6	22	1
PFV 60	PFVR 60	60	da 22 a 40	16	M16x1.5	23.7	19.5	17	14	69.5	31	36.5	16	30	8	24	1

Type		Dynamic load ⁴⁾ (N)	Limit loads ³⁾ (N)		Life coefficients		Torque wrench settings ²⁾ (Nm)	Weight (g)
concentric	eccentric	C _w	Radial F _r	Axial F _a	X	Y		
PFV 25	PFVR 25	1850	1080	200	1	4.4	8	42
PFV 35	PFVR 35	4550	1500	350	14	4.4	20	115
PFV 43	PFVR 43	7600	1500	350	1	4	26	210
PFV 50	PFVR 50	8800	4240	940	1	4	44	335
PFV 60	PFVR 60	15700	5360	1350	1	4.3	64	570

1) Housing bore tolerance: H7

2) The torque wrench settings are given for non-lubricated threads; for lubricated threads, multiply figure by 0.8

3) To avoid wear of the guide, do not exceed 25% of the limit load indicated in the table

4) C_w basic load for 100 km

5) The guide rollers are complete with self-locking washers and hexagonal nut (DIN 439B) for fitting

6) Pressure angle α for load calculation: 60°

7) NBR seals, RS type

NOTE

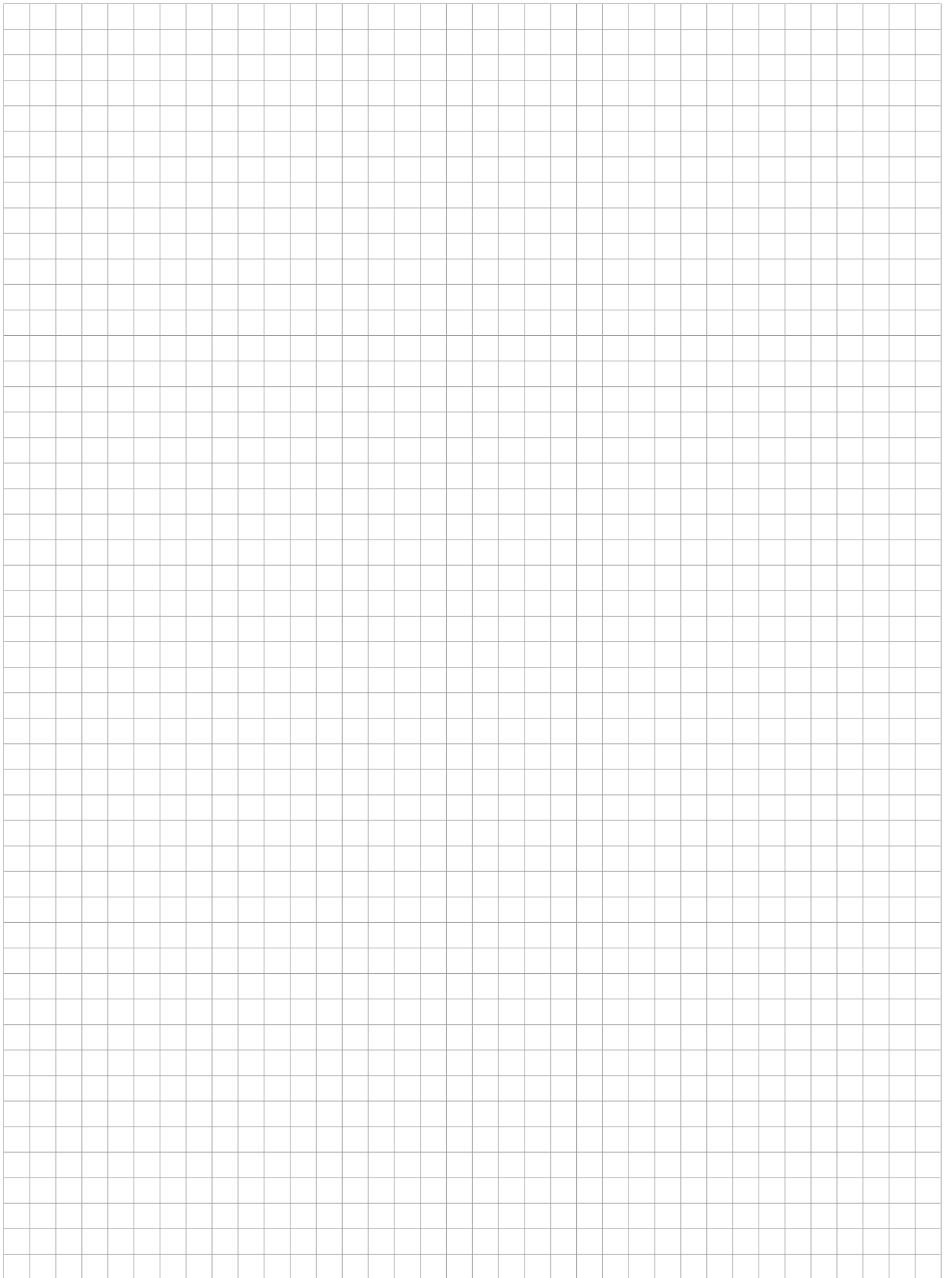

BASE-LINE – DC, C SYSTEMS

GUIDE ROLLERS RKO

Guide rollers with tapered roller bearings, with "gothic arch" profile.



CONCENTRIC

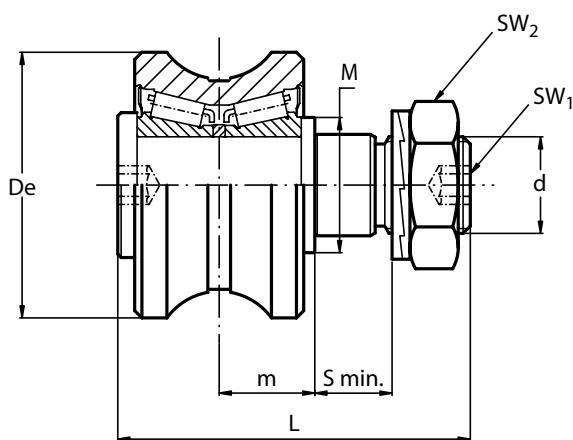

ECCENTRIC

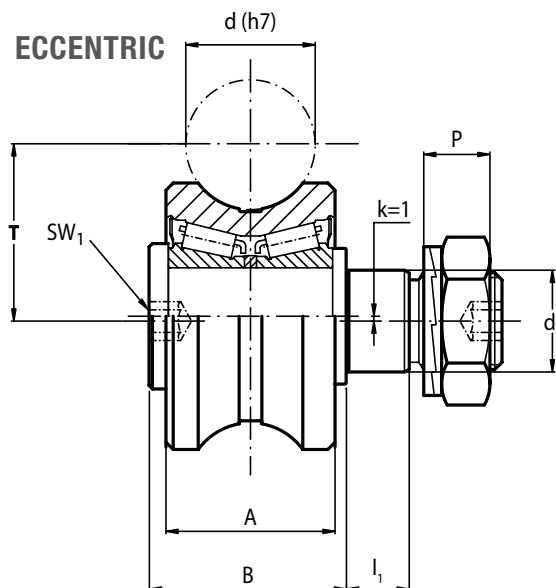

Type		Dimensions (mm)																
concentric	eccentric	De	d-h7	d ₁ ¹⁾	d	T	m	S min.	P	L	A	B	l ₁	M	SW ₁	SW ₂	k	Recommended pairings
RKO 55.20	RKOR 55.20	55	20	21	M20 x 1.5	32.9	19.8	15	13.4	73	35	41	14	28	8	30	1	Albero Ø20
RKO 55.25	RKOR 55.25	55	25	21	M20 x 1.5	34.3	19.8	15	13.4	73	35	41	14	28	8	30	1	DC 25.95
RKO 62.30	RKOR 62.30	62	30	21	M20 x 1.5	39.6	19.8	15	13.4	73	35	41	14	28	8	30	1	C30
RKO 80.40	RKOR 80.40	79	40	36	M30 x 1.5	50.7	27	19	19.6	100	45	55	18	44	12	46	1	Albero Ø40

1) Housing bore tolerance: H7

Type		Dynamic load (N)	Limit loads (N)		Life coefficients		Torque wrench settings ³⁾ (Nm)	Weight (kg)
concentric	eccentric	C _w ²⁾	Radial F _r	Axial F _a	X	Y		
RKO 55.20	RKOR 55.20	42000	11900	4000	1	3.3	80	0.6
RKO 55.25	RKOR 55.25	42000	11900	4000	1	3.4	80	0.6
RKO 62.30	RKOR 62.30	44000	11900	4000	1	3.7	80	0.7
RKO 80.40	RKOR 80.40	68000	31000	10000	1	3.2	300	1.6

2) C_w basic load for 100 km

3) Torque wrench settings are given for non-lubricated threads; for lubricated threads, multiply figure by 0.8

- Standard seals: material NBR, type RS
- On request, the guide rollers can be supplied with Viton seals for operating temperatures up to 120°C (suffix V)
- The guide rollers are complete with self-locking washers and hexagonal nut for fitting
- Pressure angle α for load calculation: 65°

CARRIAGES T4 PFV

Carriages with anodised aluminium body with four guide rollers type PFV with "gothic arch" profile.

Available in stainless steel version.

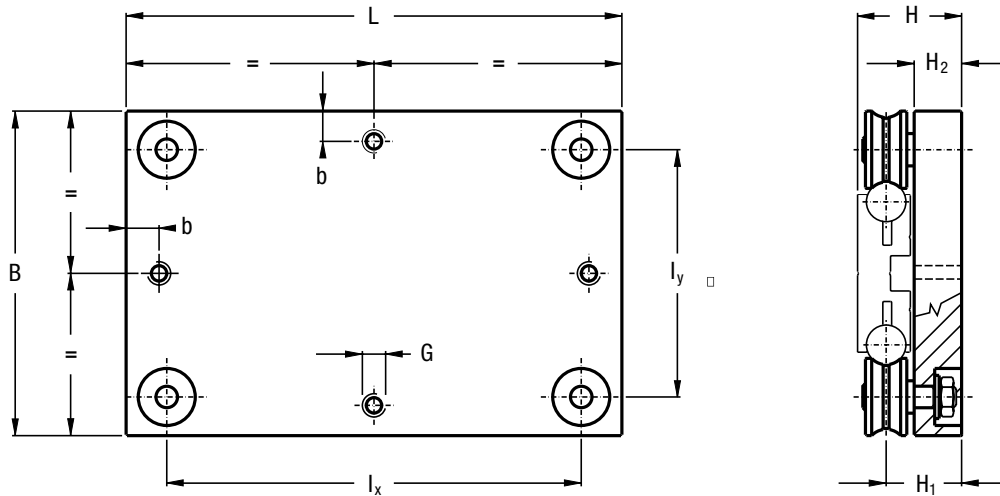

Type	Dimensions (mm)									Weight (kg)	Recommended pairings
	L	B	L _x	L _y	H	H ₁	H ₂	G	b		
T4 PFV 25 10 80 ¹⁾	80	120	45	85	41	28	20.5	M8	15	0.69	DC 10.54
T4 PFV 25 10 120 ¹⁾	120	120	85	85	41	28	20.5	M8	15	0.96	DC 10.54
T4 PFV 35 16 165 ¹⁾	165	165	126	126	50.5	36	24	M8	15	2.1	DC 16.80
T4 PFV 35 16 250 ¹⁾	250	165	211	126	50.5	36	24	M8	15	3.1	DC 16.80
T4 PFV 35 18 150 ¹⁾	150	150	113	113	49	36	24	M8	15	1.8	DC 18.65
T4 PFV 35 18 250 ¹⁾	250	150	213	113	49	36	24	M8	15	2.8	DC 18.65
T4 PFV 50 25 220 ¹⁾	220	220	163	163	63.5	45.5	29	M10	20	5	DC 25.95
T4 PFV 50 25 300 ¹⁾	300	220	243	163	63.5	45.5	29	M10	20	6.4	DC 25.95

¹⁾ Available with stainless steel guide rollers (NX)

- Carriages are complete with guide rollers
- Pressure angle α for load calculation: 60°

BASE-LINE – DC, C SYSTEM

WIPER NAID

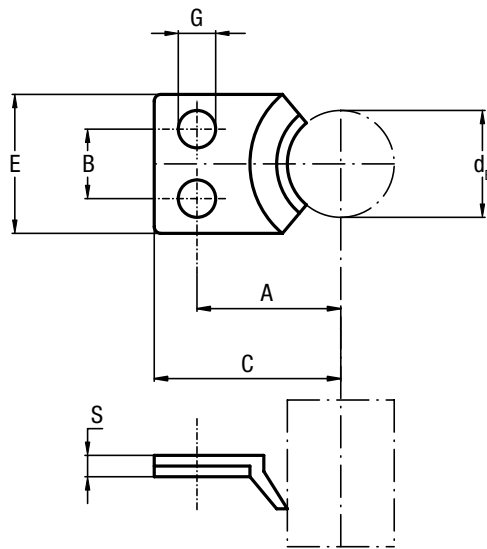
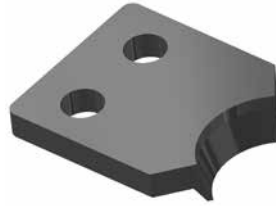

Type	Dimensions (mm)							Suggested combinations
	d_B	E	C	A	B	G	S	
NAID 010	10	13	17.5	13.5	6.5	3.5	3	C 10
NAID 016	16	20	26.5	20.5	10	4.5	3	DC 16.80
NAID 018	18	20	26.5	20.5	10	4.5	3	C 18, DC 18.65
NAID 022	22	24	30.0	24.0	14	4.5	3	C 22
NAID 025	25	28	37.5	30.5	18	4.5	3	DC 25.95
NAID 030	30	32	45.5	37.5	20	5.5	3	C 30

LUBRICATOR LUBC

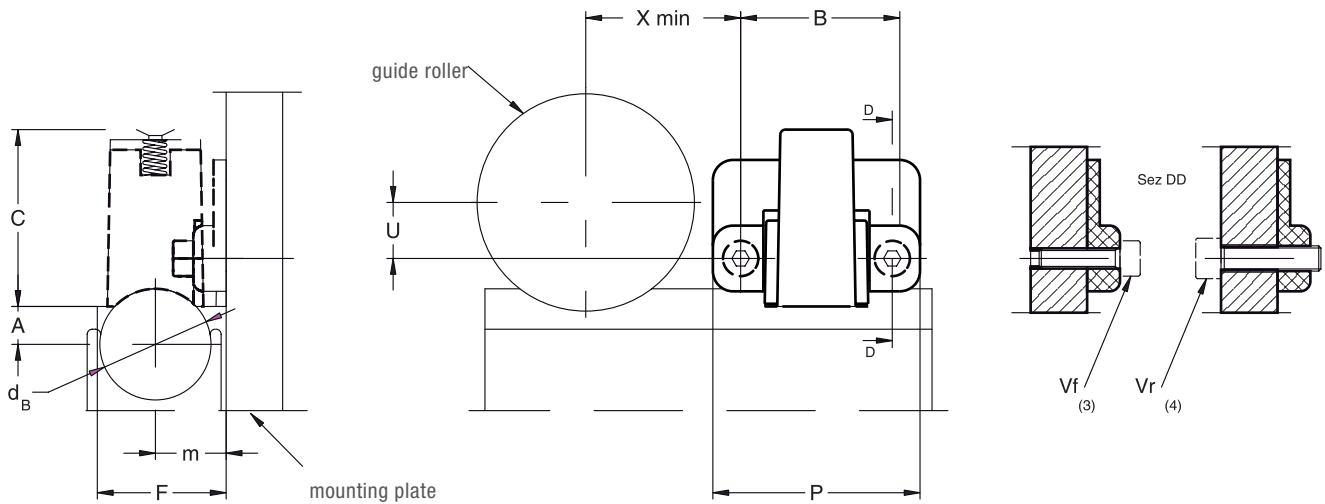
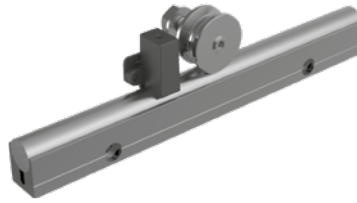

Type	Dimensions (mm)											Weight (g)	Suggested combinations
	X	U	B	F	m	d _B	A	C	P	Vf ¹⁾	Vr ²⁾		
LUBC 25.10	18	4.5	25	13	7.5	10	3	22	32.5	M3 x 12	M4	10	PFV 25.10
LUBC 35.16	23	9.5	25	22	12	16	5.5	32	32.5	M3 x 12	M4	15	PFV 35.16
LUBC 35.18	23	9.5	25	22	12	18	6.5	32	32.5	M3 x 12	M4	15	PFV 35.18
LUBC 43.22	29	12	30	25.5	14	22	22	35	41	M4 x 12	M5	30	PFV 43.22
LUBC 50.25	32.5	15.5	30	30.5	16.5	25	9	45	41	M4 x 12	M5	35	PFV 50.25
LUBC 60.30	37.5	20.5	30	36.5	19.5	30	11	50	41	M4 x 12	M5	40	PFV 60.30

1) The screws Vf for the frontal mounting are included in the packaging. Arrange two thread holes for dimension Vf in the mounting rollers plate

2) The screw for the mounting on the nut side of the roller are not included in the packaging. Arrange on the mounting rollers plate the holes in order to insert the screws Vr

- The lubricator is supplied with the felt already lubricated. The lubricant has a mineral oil base
- At the mounting, insert the screws inside the rollers plate, without tightening them, adjust the height of the plastic part in order to put it in contact with the raceways and then block it

OPTIONAL FEATURES

- Felt without lubricant (D)

BASE-LINE – FWS, FWH SYSTEM

GUIDE RAILS FWS

Rail composed by an aluminium body and two shafts in steel, with two raceways.

Available in stainless steel version.

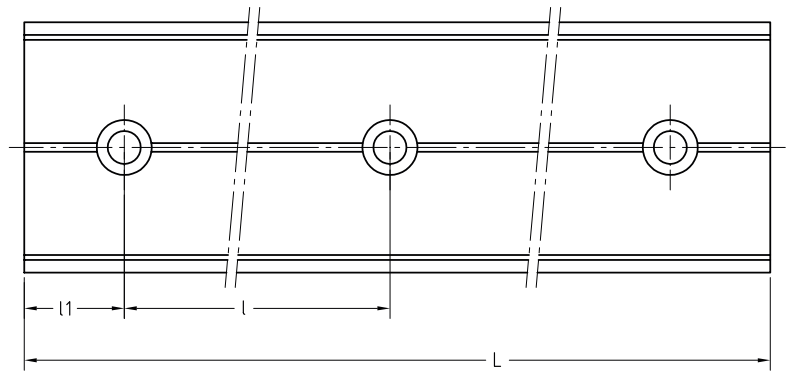
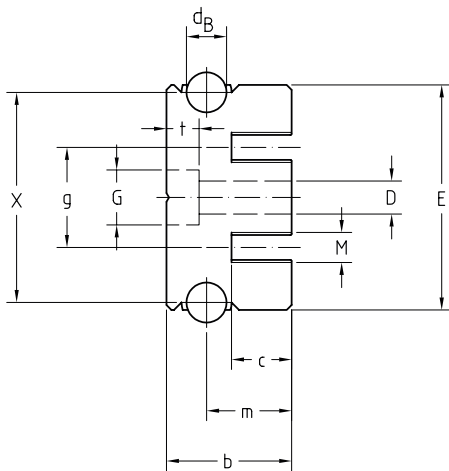

Type	Dimensions (mm)											Reductions		
	d _B	a	M	g	E	b	m	c	l	l ₁	G	D	t	
FWS 22	6	34	M5	16	36	20	14	10	120	30	10	5.5	5.5	
FWS 32	8	42	M6	20	45	25	17	12	120	30	11	6.5	6.5	
FWS 40	10	54	M8	24	57	30	19	14	150	30	15	9	9	
FWS 52	12	66	M10	32	69	36	24	18	150	30	18	11	11	

Max. length in single element L = 4500 mm.

Longer rails are supplied in sections with ground butt joints and, on request, with pin connection

Type	Screw distance max.			Moments of inertia ¹⁾		Weight (kg/m)
	for 2 screw channels		for additional holes (NZ)	J _x (cm ⁴)	J _y (cm ⁴)	
	Distance (mm)	Torque wrench settings (Nm)	Distance (mm)			
FWS 22	190	2	220	2.07	6.01	2.0
FWS 32	210	5	240	5.10	14.56	3.3
FWS 40	250	15	280	11.01	35.26	5
FWS 52	250	23	280	22.85	74.12	7.2

¹⁾ Inertia value based on equivalent aluminium yield 70000 N/mm² including shafts

HOLE LAYOUT

- Holes according to catalogue (SB)
- Finishes to drawing (NZ)
- Without holes (NF)

OPTIONAL FEATURES

- Ground one end: side of the first hole (1R), side of the last hole (2R)
- Ground both ends (RR)
- Stainless steel shafts (NX)
- Chromium plated shafts (CH)
- Pin based shaft connection (G)

Example of standard designation: FW S32/1500 NF

GUIDE FWH

Rail composed by an aluminium body and one shaft in steel, with a single raceway.

Available in stainless steel version.

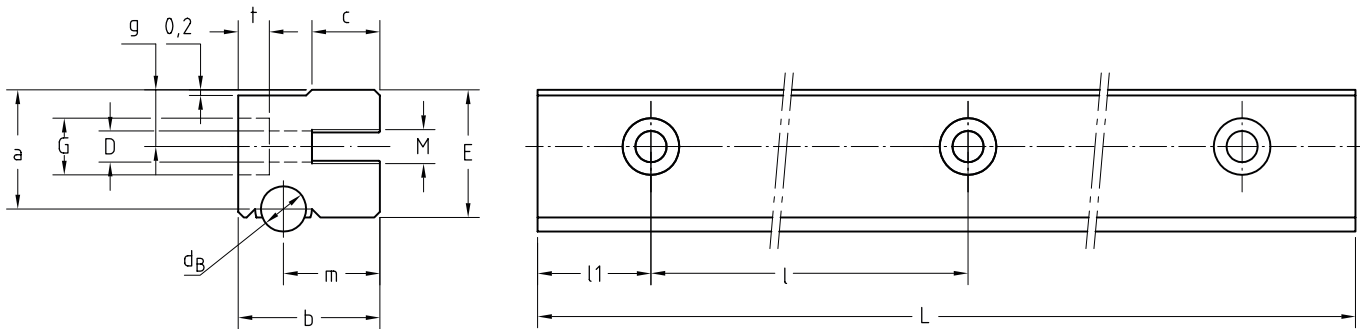

Type	Dimensions (mm)												
	d _B	a	M	g	E	b	m	c	l	l ₁	Reductions		
											G	D	t
FWH 22	6	17	M5	8	18	20	14	10	120	30	8	4.5	4.5
FWH 32	8	21	M6	10	22.5	25	17	12	120	30	10	5.5	5.5
FWH 40	10	27	M8	12	28.5	30	19	14	150	30	11	6.5	6.5
FWH 52	12	33	M10	16	34.5	36	24	18	150	30	15	9	9

Max. length in single element L = 4500 mm.

Longer rails are supplied in sections with ground butt joints and, on request, with pin connection

Type	Screw distance max.			Moments of inertia ¹⁾		Weight (kg/m)	
	for 1 screw channels		for additional holes		J _x (cm ⁴)		J _y (cm ⁴)
	Distance (mm)	Torque wrench settings (Nm)	Distance (mm)				
FWH 22	70	2	120		1.02	0.83	1
FWH 32	60	5	130		2.55	2.05	1.6
FWH 40	97	15	150		5.71	4.75	2.5
FWH 52	120	23	150		10.12	11.85	3.6

¹⁾ Inertia value based on equivalent aluminium yield 70000 N/mm² including shafts

HOLE LAYOUT

- Holes according to catalogue (SB)
- Finishes to drawing (NZ)
- Without holes (NF)

OPTIONAL FEATURES

- Ground one end: side of the first hole (1R), side of the last hole (2R)
- Ground both ends (RR)
- Stainless steel shafts (NX)
- Chromium plated shafts (CH)
- Pin based shaft connection (G)

Example of standard designation: FWH 32 / 1500 NF

BASE-LINE – FWS, FWH SYSTEM

GUIDE ROLLERS FR ... EU

Guide roller with ball bearings.
The sides of the race are slightly convex.

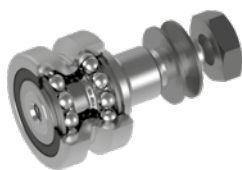

Available in stainless steel version.

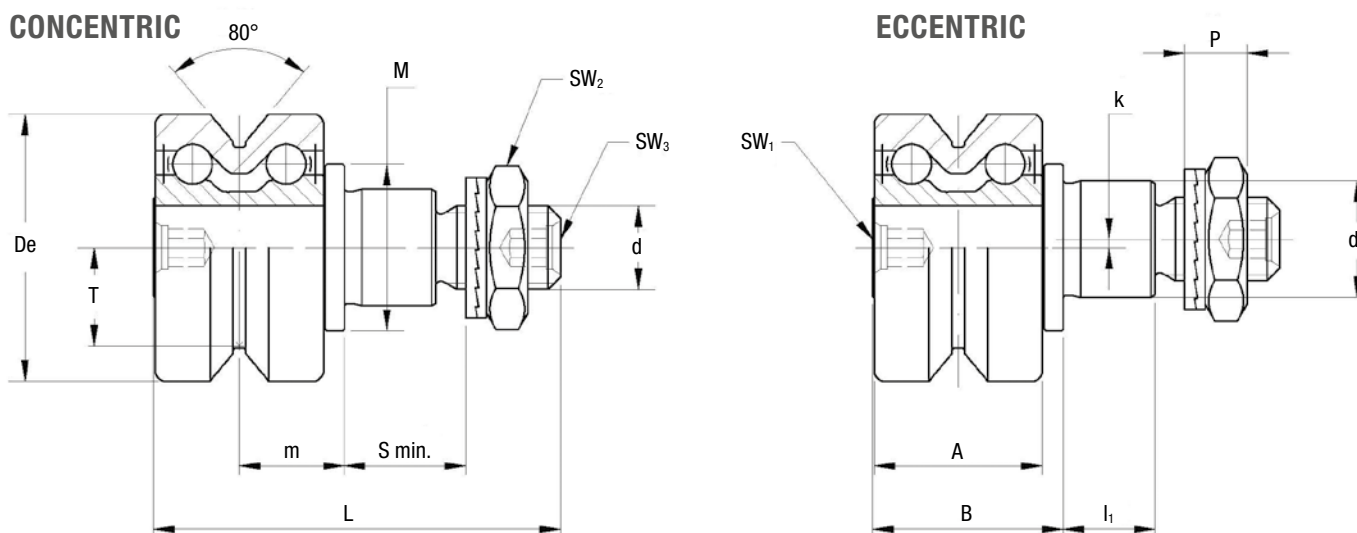

Type		Dimensions (mm)															
concentric	eccentric	De	d ₁ ³⁾	d	T	m	S min.	P	L	A	B	I ₁	M	SW ₁	SW ₂	SW ₃	k
FR 22 EU ^{1) 2)}	FRR 22 EU ^{1) 2)}	22	9	M6 x 1	7.7	9.4	9	6.5	36.8	15	18	8	14	4	10	2,5	0.5
FR 32 EU ¹⁾	FRR 32 EU ¹⁾	32	14	M10 x 1.25	11.8	12.6	12	8.5	48.9	20.2	22.9	11	20	4	17	4	1
FR 40 EU ¹⁾	FRR 40 EU ¹⁾	40	16	M12 x 1.5	14.6	15.5	12	10.4	58.5	25	29.5	11	22	5	19	5	1
FR 52 EU	FRR 52 EU	52	21	M16 x 1.5	19.1	19.8	15	11.4	69.5	32	36.5	14	28	6	24	6	1.5

1) FR/R 22, 32, 40 are available in stainless steel (NX)

2) FR/R 22 EUNX: VAC for high vacuum applications on request

3) Housing bore tolerance: H7

Type		Dynamic load (N)	Limit loads (N)		Life coefficients		Torque wrench settings ⁵⁾ (Nm)	Weight (g)
concentric	eccentric	C _w ⁴⁾	Radial F _r	Axial F _a	X	Y		
FR 22 EU	FRR 22 EU	2900	1400	420	1	2	5	45
FR 32 EU	FRR 32 EU	5800	2000	800	1	1.9	20	125
FR 40 EU	FRR 40 EU	8500	3650	1400	1	1.9	26	230
FR 52 EU	FRR 52 EU	11700	8500	3000	1	1.9	64	510

4) C_w basic load for 100 km

5) The torque wrench settings are given for non-lubricated threads; for lubricated threads, multiply figure by 0.8

- The guide rollers are complete with self-locking washers and hexagonal nut (DIN 439B) for fitting
- Pressure angle α for load calculation: 40°
- NBR seals RS type

GUIDE ROLLERS FR ... EU AS, FR ... EU AZ

Floating guide rollers with ball bearings.

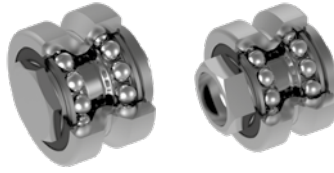

Available in stainless steel version.



AS

CONCENTRIC

ECCENTRIC

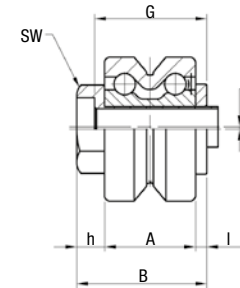
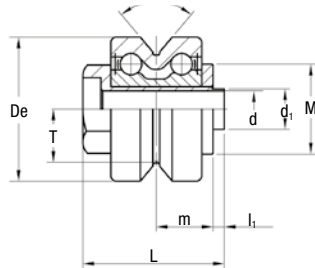
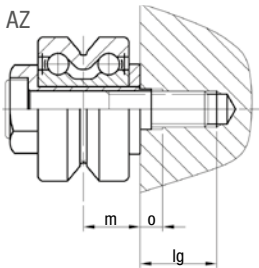
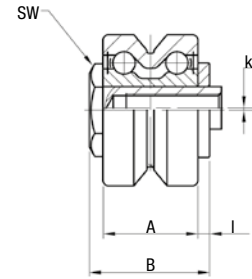
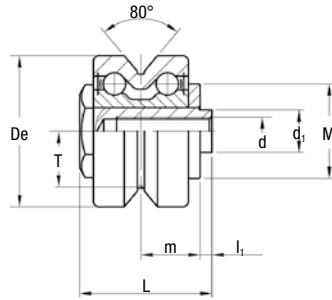
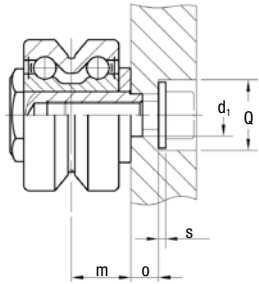

Type

Dimensions (mm)

Type	concentric	eccentric	De	d ₁ ²⁾	d ³⁾	T	m	L	A	B	I ₁	I	h	M	SW	G	o	Q	Ig ⁴⁾	s	k
FR 22 EU AS ¹⁾	FRR 22 EU AS ¹⁾		22	6	M5	7.7	9.4	21.8	15	19.8	2	1.9	-	14	10	-	4.5	10	-	-	0.5
FR 32 EU AS ¹⁾	FRR 32 EU AS ¹⁾		32	9	M6	11.8	12.6	28.1	20.2	25.6	2.5	2.5	-	20	17	-	6	15	-	1.5 ⁵⁾	0.5
FR 40 EU AS ¹⁾	FRR 40 EU AS ¹⁾		40	11	M8	14.6	15.5	33.5	25	31	2.5	3	-	22	22	-	6.5	20	-	2 ⁵⁾	1
FR 52 EU AS	FRR 52 EU AS		52	16	M10	19.1	19.8	43.2	32	40	3.2	3.8	-	28	27	-	8	24	-	2.5 ⁵⁾	1.5
FR 22 EU AZ ¹⁾	FRR 22 EU AZ ¹⁾		22	6	5.1	7.7	9.4	23.9	15	21.9	2	1.9	5	14	11	18.9	4	-	13	-	0.5
FR 32 EU AZ ¹⁾	FRR 32 EU AZ ¹⁾		32	9	8.1	11.8	12.6	31.4	20.2	28.9	2.5	2.5	6.2	20	17	24.9	5	-	17	-	0.5
FR 40 EU AZ ¹⁾	FRR 40 EU AZ ¹⁾		40	11	10.1	14.6	15.5	38	25	35.5	2.5	3	7.5	22	22	30.5	5	-	26	-	0.8
FR 52 EU AZ	FRR 52 EU AZ		52	16	14.1	19.1	19.8	49.5	32	46.3	3.2	3.8	10.5	28	27	39.3	5.5	-	27	-	1.5

1) FR / R 22, 32, 40 AS and AZ are available in stainless steel (NX)

2) Housing bore tolerance: H7

3) Safety threads SPIRALOCK

4) AZ: minimum length of the thread engaged

steel = 1 x d; cast iron = 1.25 x d; aluminium = 2 x d

5) Guide roller with washers DIN 134 without screw DIN 7984 or DIN 912

6) Guide roller with washers DIN 125 without screw DIN 7984 or DIN 912

Type	Dynamic load (N)	Limit loads (N)		Life coefficients		Weight AS (g)	Weight AZ (g)	On request for AZ screw DIN 7984
	C _w ⁷⁾	Radial F _r	Axial F _a	X	Y			
22	2900	470	210	1	2	33	31	M5 x 30
32	5800	1590	710	1	1.9	95	93	M8 x 40
40	8500	2120	940	1	1.9	173	173	M10 x 50
52	11700	5830	2560	1	1.9	374	365	M14 x 60

7) C_w basic load for 100 km

- NBR seals RS type

- Pressure angle α for load calculation: 40°

BASE-LINE – FWS, FWH SYSTEM

FLOATING GUIDE ROLLERS FRL ... EU

Floating guide rollers with ball bearings.
The race ways are slightly convex.

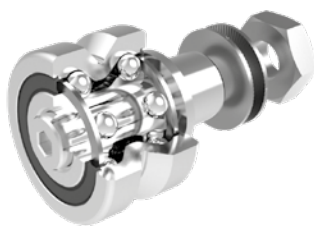

Available in stainless steel version.



CONCENTRIC

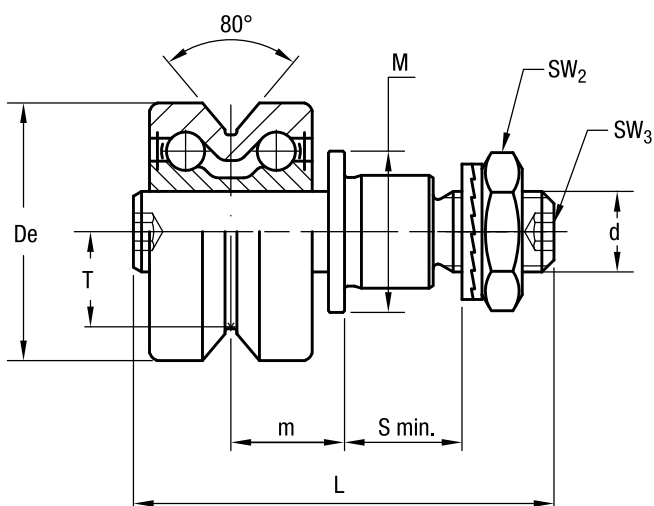

ECCENTRIC

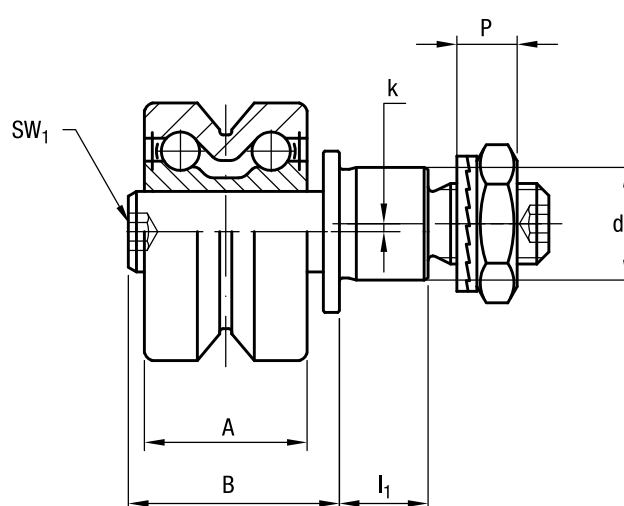

Type		Dimensions (mm)																
concentric	eccentric	De	d ₁ ²⁾	d	T	m _{min.} ³⁾	m _{max.} ³⁾	S min.	P	L	A	B	I ₁	M	SW ₁	SW ₂	SW ₃	k
FRL 22 EU ¹⁾	FRLR 22 EU ¹⁾	22	9	M6 x 1	7.7	9	13	9	6.5	39.3	15	20.5	8	14	4	10	3	0.8
FRL 32 EU ¹⁾	FRLR 32 EU ¹⁾	32	14	M10 x 1.25	11.8	12.1	16.1	12	8.5	52.2	20.2	26.2	11	20	4	17	4	1
FRL 40 EU ¹⁾	FRLR 40 EU ¹⁾	40	16	M12 x 1.5	14.6	14.9	19.9	12	10.4	61.4	25	32.4	11	22	5	19	5	1
FRL 52 EU	FRLR 52 EU	52	21	M16 x 1.5	19.1	19	25	15	11.4	74	32	41	14	28	6	24	6	1.5
FRL 62 EU	FRLR 62 EU	62	27	M20 x 1.5	22.1	19.8	25.8	18.5	12.4	83.6	33.6	42.6	17.5	35	8	30	8	2

1) Dimensions for stainless steel (NX) version

2) Housing bore tolerance: H7

3) To ensure a safe and proper functioning the dimension m must not be higher than m_{max.}

Type		Dynamic load (N)	Limit loads (N)	Limit load Inox version (N) NX	Torque wrench settings ⁵⁾ (Nm)	Weight ⁶⁾ (g)
concentric	eccentric	C _w ⁴⁾	Radial F _r	Axial F _a		
FRL 22 EU	FRLR 22 EU	2900	1050	900	3	46
FRL 32 EU	FRLR 32 EU	5800	1700	1500	20	127
FRL 40 EU	FRLR 40 EU	8500	3000	2700	26	233
FRL 52 EU	FRLR 52 EU	11700	7600	–	64	520
FRL 62 EU	FRLR 62 EU	13900	11000	–	120	776

4) C_w = Basic load for 100 Km

5) The torque wrench settings are given for non-lubricated threads; for lubricated threads multiply figure by 0.8

6) Weight without fittings

- Standard seals: material NBR, RS type
- Guide rollers include self-locking washers and hexagonal nut (DIN 439B)
- Pressure angle α for load calculation: 40°

CARRIAGE T4 FR

Carriages with anodised aluminium body with four guide rollers type FR ... for FWS rails.

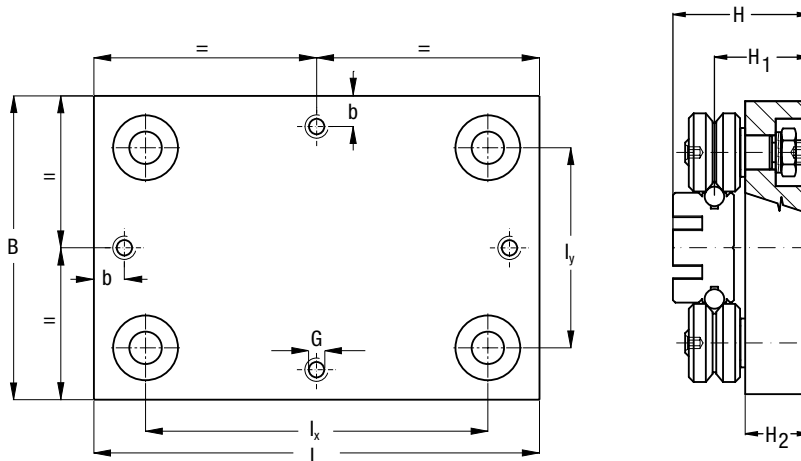

Type	Dimensions (mm)									Weight (kg)	Suggested combinations
	L	B	I _x	I _y	H	H ₁	H ₂	G	b		
T4 FR 22 90	90	90	59	58.7	42.4	28.4	19	M6	15	0.6	FWS 22
T4 FR 22 150	150	90	119	58.7	42.4	28.4	19	M6	15	0.9	FWS 22
T4 FR 32 120	120	120	78	78	58.6	41.6	29	M8	15	1.5	FWS 32
T4 FR 32 180	180	120	138	78	58.6	41.6	29	M8	15	2.1	FWS 32
T4 FR 40 150	150	150	99	98.8	63.5	44.5	29	M8	15	2.6	FWS 40
T4 FR 40 220	220	150	169	98.8	63.5	44.5	29	M8	15	3.4	FWS 40
T4 FR 52 190	190	190	123	123	82.8	58.8	39	M10	20	5.4	FWS 52
T4 FR 52 260	260	190	203	123	82.8	58.8	39	M10	20	6.8	FWS 52

BASE-LINE – FWS, FWH SYSTEM

GUIDE ROLLERS COMBINATION

8.4

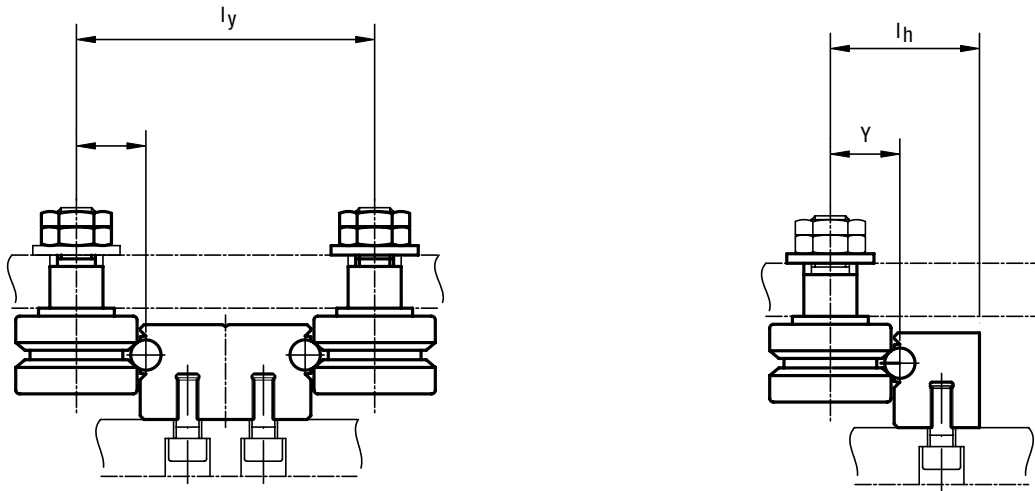

Type	Roller type FR / FRR ... EU, FR / FRR ... EU AS, FR / FRR ... EU AZ, FRL / FRLR ... EU			
Guide	Rollers	Y	l_y	l_h
FWS 22	FWH 22	12.4	58.8	29.4
FWS 32	FWH 32	18	78	39
FWS 40	FWH 40	22.4	98.8	49.4
FWS 52	FWH 52	28.4	122.8	61.4

MOUNTING EXAMPLES

Glue dispensing machine

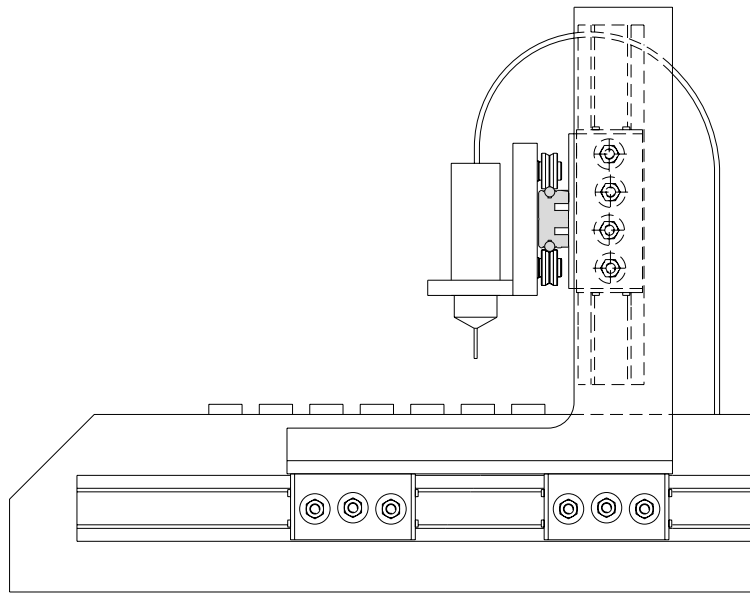

Oxy cutting machine
Base-Line C and DC

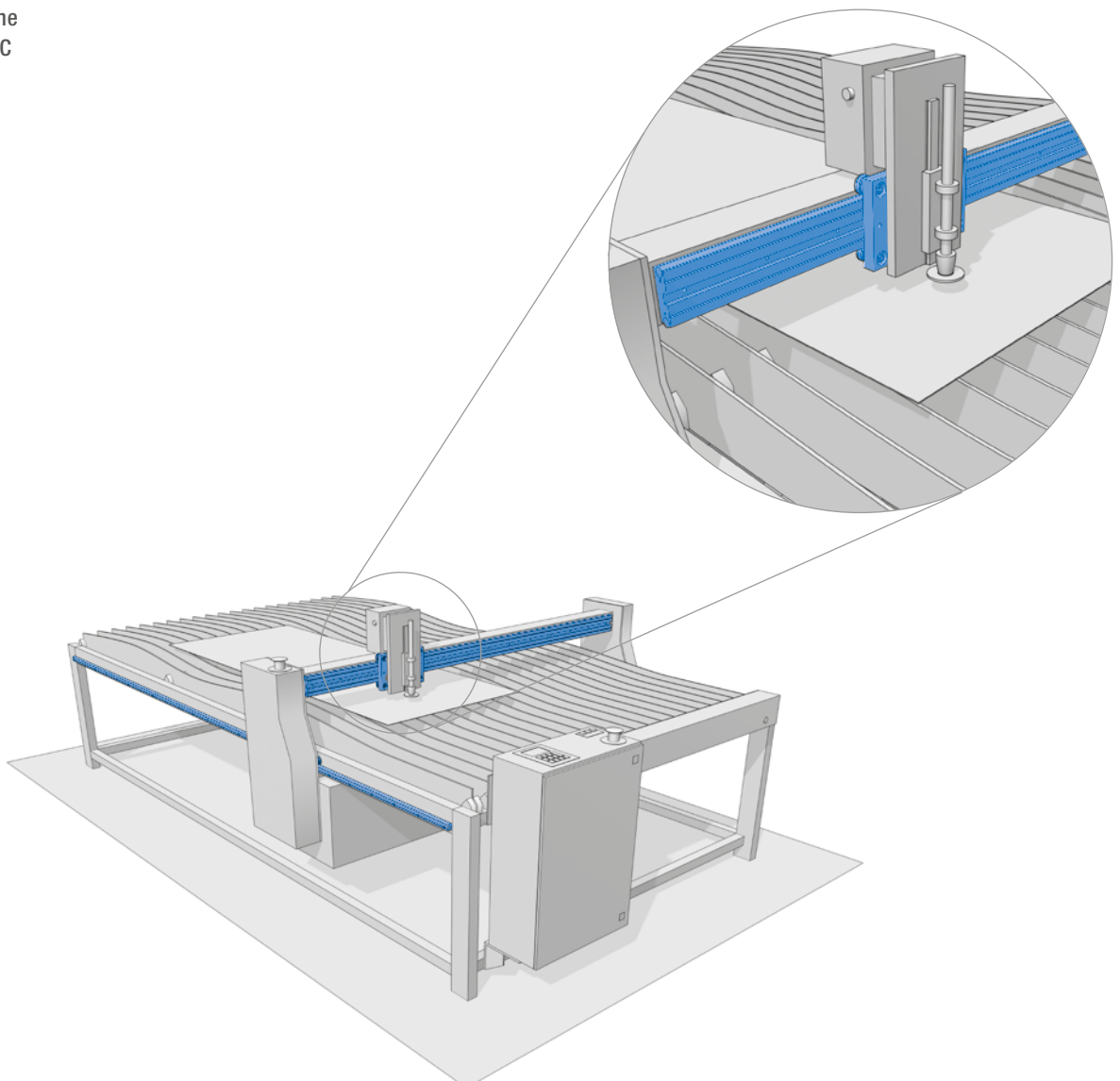

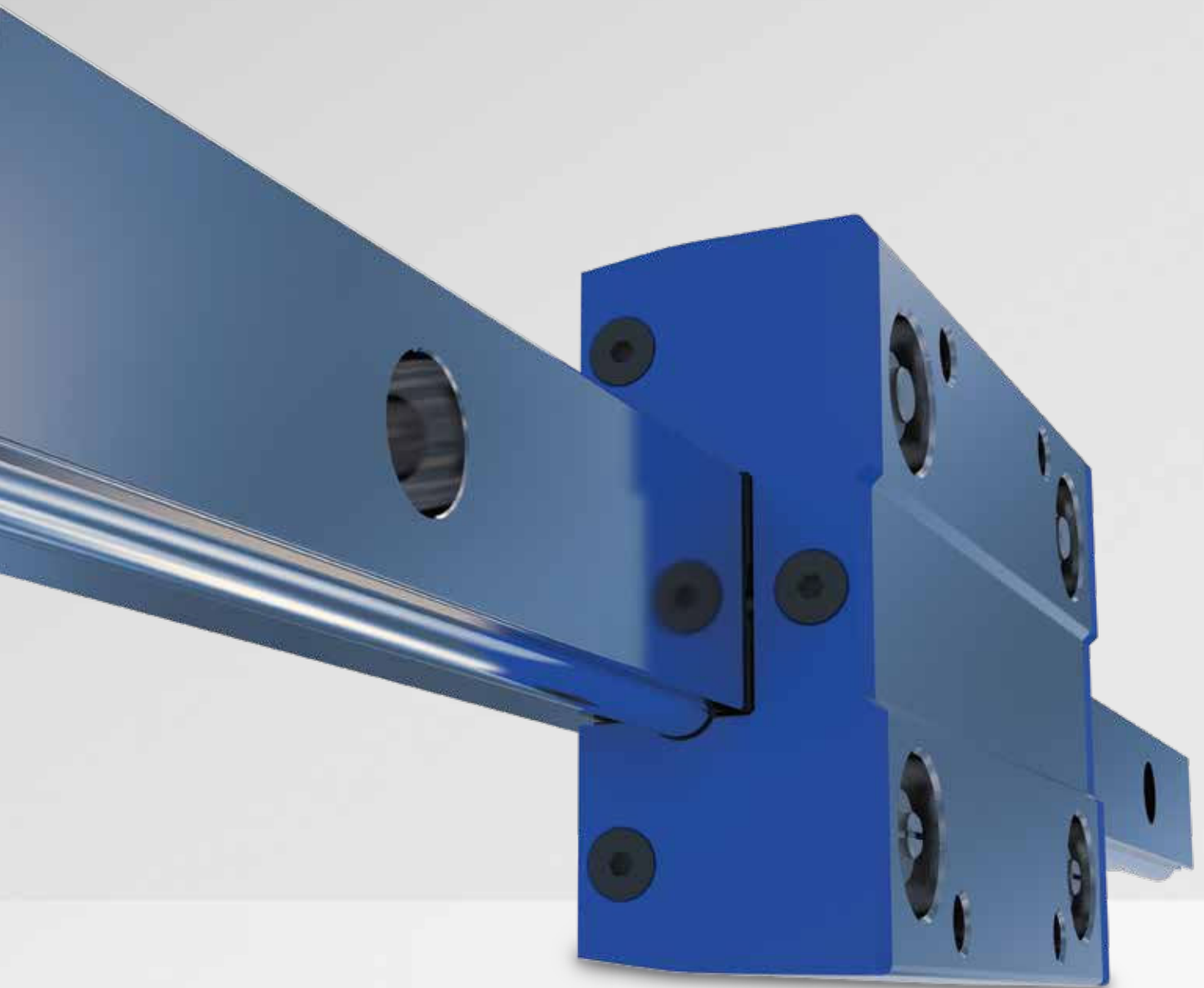

FLEXI-LINE 645

9

PAGE 124

9.1 PRODUCT DESCRIPTION

PAGE 125

9.2 FWN SYSTEM

For light-medium loads

- Guide rails FWN
- Carriage TA4
- Carriage TB4

PAGE 127

9.3 MOUNTING EXAMPLE

FLEXI-LINE 645 PRODUCT DESCRIPTION

KEY BENEFITS

- Dimensions according to DIN 645 with flexible configuration
- For light and medium loads
- Ready-to-install



Aluminium guide rails FWN as well as carriages TA4 and TB4 are the components of this line. In addition to the standard dimensions that are DIN 645 compatible, the guide system can be adapted to customers' requirements. Bore holes and threads on the guide rails can be made in any distance required, the carriages may have over-lengths and a special hole pattern.

Compared to linear guides made of steel these guide rails and carriages weigh up to 45 % less and stand out due to their excellent running performance which minimises the driving power and reduces significantly the cost for motors and controls.

With eccentric bolts the guide rollers of the carriages are kept free from play. However the user also has the possibility to change the settings, for example in case of vibrations, and to apply an individual preload on the guide system. On both sides of the carriages end plates with oil-soaked felt seals can be mounted to ensure low-wear operation.

The following graph applies to the loads indicated in the tables:

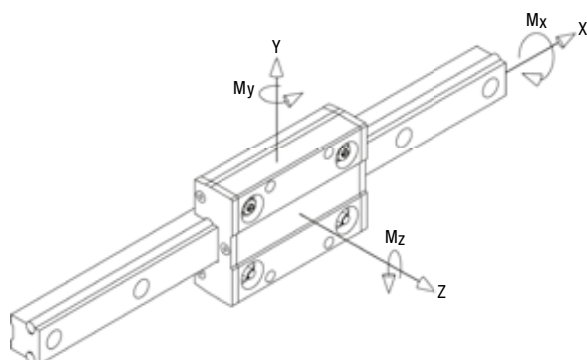

DYNAMIC LOAD OF THE INDIVIDUAL CARRIAGE

The table below shows the load corresponding to the nominal working life of 100 km. The nominal working life of the carriage can be determined by the standard bearing formula.

$$L_{10} = (C_i / P_i)^3 \times 100 \text{ km}$$

C_i is the carrying capacity in a specific direction and P_i is the load applied in the same direction.

Carriage	C _y (N)	C _z (N)	CM _x (Nm)	CM _y (Nm)	CM _z (Nm)
TA4 GLA 17.06 TB4 GLA 17.06	2596	1445	13	46	84
TA4 GLA 19.06 TB4 GLA 19.06	4920	2700	30	100	180

IMPORTANT REMARK

- Values are calculated on the basis of lubricated rails.
- For combined loads please proceed as indicated in the calculation examples at the end of the catalogue. In case of questions our application engineers will be pleased to assist you.

MAXIMUM LOAD ON INDIVIDUAL CARRIAGES

The table below shows the maximum load that can be applied to an individual carriage.

Carriage	F _y (N)	F _z (N)	M _x (Nm)	M _y (Nm)	M _z (Nm)
TA4 GLA 17.06 TB4 GLA 17.06	600	400	5	15	20
TA4 GLA 19.06 TB4 GLA 19.06	1700	960	19	33	70

FLEXI-LINE 645 – FWN SYSTEM

GUIDE RAILS FWN

9.2

Rail composed by an aluminium body and two shafts in steel, with two raceways. Dimensions according to DIN 645.

Available in stainless steel version.

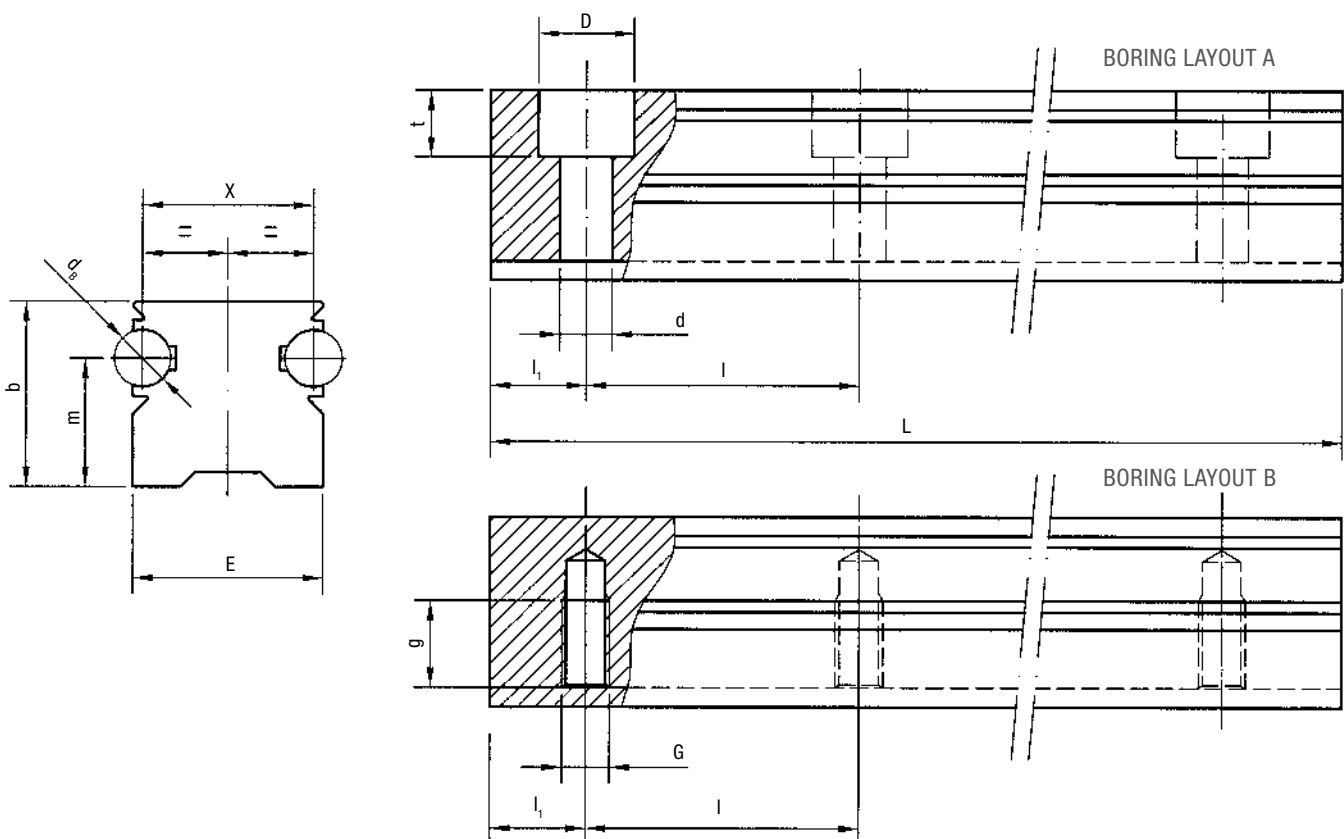

Type	Dimensions (mm)												Weight (kg/m)
	d_B	E	X	D	d	G	g	m	t	b	l_1	l	
FWN 20	6	20	18	10	5.5	M6	12	13.5	7	19.5	30	60	1.3
FWN 25	6	23	21	11	6.6	M6	12	18.0	8.5	25.5	30	60	1.8

Max. length in single element L = 5800 mm. Longer rails are supplied in sections with ground butt joints and, on request, with pin connection

HOLE LAYOUT

- Holes according to DIN (A or B)
- Finishes to drawing (NZ)
- Without holes (NF)

OPTIONAL FEATURES

- Ground one end: side of the first hole (1R), side of the last hole (2R)
- Ground both ends (RR)
- Stainless steel shafts (NX)
- Chromium plated shafts (CH)
- Pin based shaft connection (G)

Example of standard designation: FWN 20 / 1000 A

FLEXI-LINE 645 – FWN SYSTEM

CARRIAGE TA4 AND TB4

Carriages with anodised aluminium body
with four guide rollers type GLA for FWN rails.
Dimensions according to DIN 645.

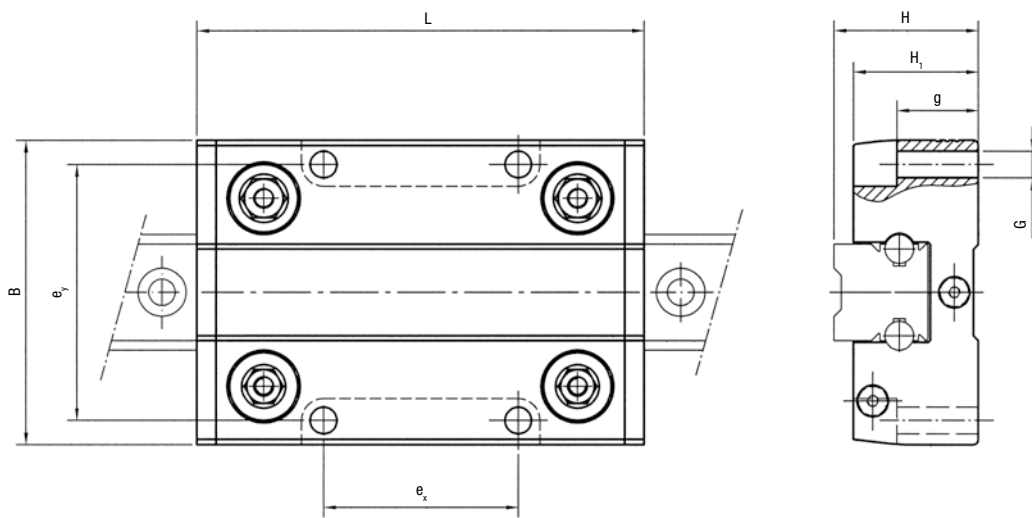

Type	Dimensions (mm)								Weight (kg)	Suggested combinations
	B	G	H	H ₁	L	e _x	e _y	g		
TA4 GLA 17.06	63	M6	30	26	92	40	53	12	0.3	FWN 20
TA4 GLA 19.06	70	M8	36	31	104	45	57	16	0.4	FWN 25
TB4 GLA 17.06	63	5,5	30	26	92	40	53	17	0.25	FWN 20
TB4 GLA 19.06	70	6,6	36	31	104	45	57	23,5	0.35	FWN 25

Longer carriages on request

MAX. LOAD ON A SINGLE CARRIAGE

Carriage	F _y (N)	F _z (N)	M _x (Nm)	M _y (Nm)	M _z (Nm)
TA4 GLA 17.06	600	400	5	15	20
TA4 GLA 19.06	1700	960	19	33	70
TB4 GLA 17.06	600	400	5	15	20
TB4 GLA 19.06	1700	960	19	33	70

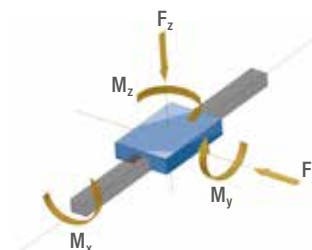

OPTIONAL FEATURES

- Available with felts for lubrication, non lubricated (UU).
On request the felts can be supplied lubricated

FLEXI-LINE 645 MOUNTING EXAMPLE

Medical equipment
Flexi-Line

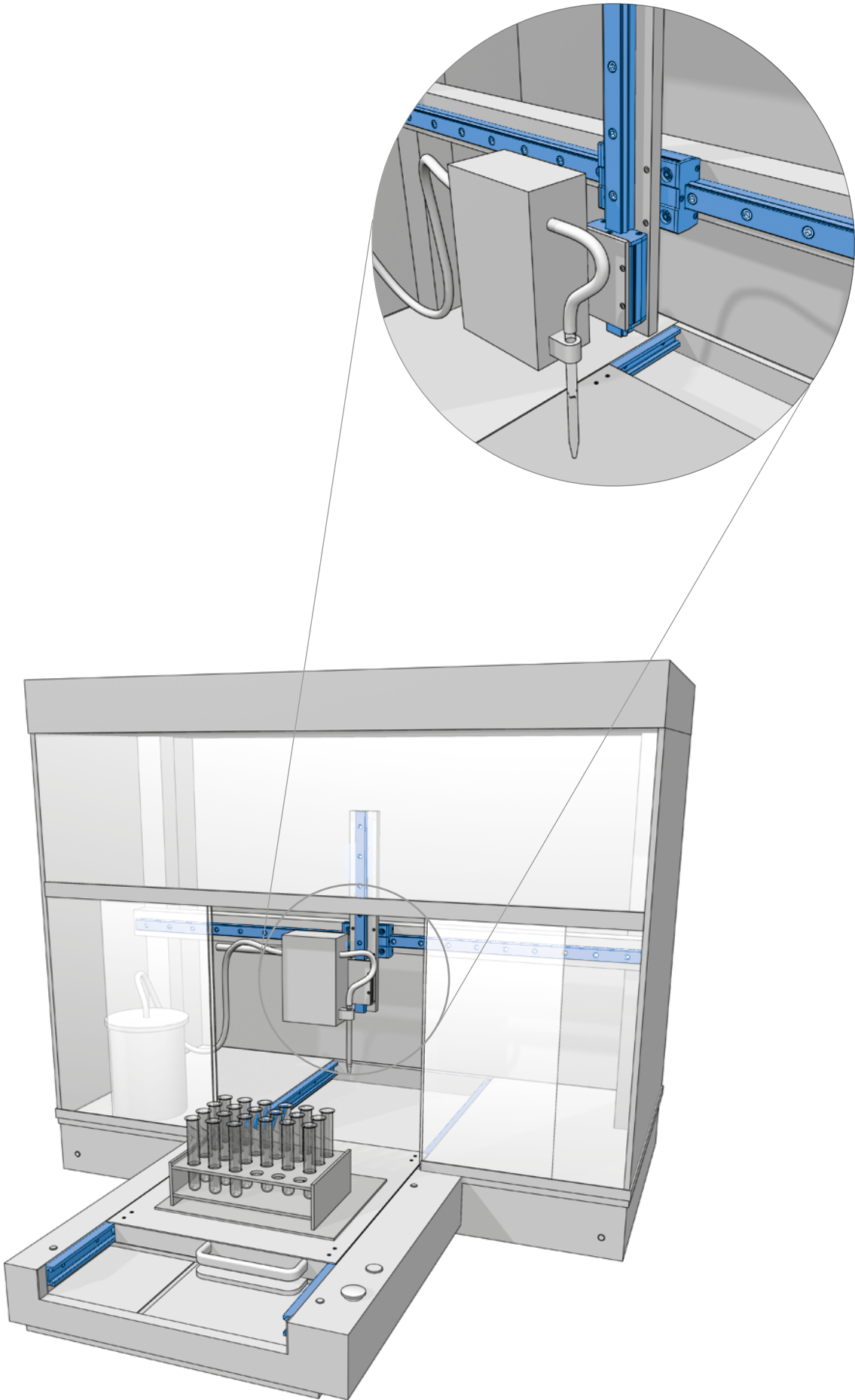



U-LINE

10

PAGE 130

10.1 PRODUCT DESCRIPTION

- LM system
- Auto-aligning system
- LML system

PAGE 134

10.2 LM SYSTEM

For light-medium loads

- Guide rails LM
- Guide rollers RCL, RCP, PFV
- Guide rollers RAL
- Guide wheels GLA
- Carriage C3 RCL, C3 RAL, C3 RYL
- Carriage C4 RCL, C4 RAL, C4 RYL
- Carriage T4 RCL, T4 RCP, T4 PFV, T4 RAL, T4 RYL
- Lubricator LUBM

PAGE 142

10.3 LML SYSTEM

For light-medium loads

- Guide rails LML
- Carriage C3 RCL 16 NX
- Carriage C4 RCL 16 NX

PAGE 144

10.4 MOUNTING EXAMPLE

U-LINE – PRODUCT DESCRIPTION

LM SYSTEM

KEY BENEFITS

- For light and medium loads
- Compact design of U-Line guides with inside carriage
- Guide rails with stainless steel shafts
- Carriages with stainless steel guide rollers



LM system is based on rail, guide rollers and carriages to provide a complete guiding system. Guide rails and rollers can be used as single elements. In most cases the application is based on standard carriages and cursors.

Referring to the axis system below, the load capacities are tabulated as follows:

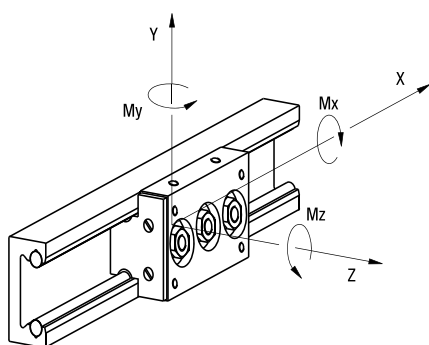

MAX. LOAD ON SINGLE CARRIAGE

The following table shows the maximum load that can be applied on a single carriage.

Guide	Carriage	Fy (N)	Fz (N)	Mx (Nm)	My (Nm)	Mz (Nm)
LM 30	C3 RCL 17 06 065	1000 ¹⁾	300	3.3	5.8	10
	C4 RCL 17 06 085	1000	600	6.4	10	20
LM 40	C3 RCL 24 06 085	1810 ¹⁾	520	7.6	15	26
	C4 RCL 24 06 114	1810	1040	15	25	52
LM 65	C3 RCL 35 10 115	4160 ¹⁾	1200	26	45	78
	C4 RCL 35 10 152	4160	2400	50	75	155
LM 90	C4 RCL 35 10 180	4160	2400	75	95	200
LM 120	T4 RCL 35 10 150	4160	2400	110	120	200
	T4 RCL 35 10 220	4160	2400	110	200	350
	T4 RCP 42 10 150	5250	3030	140	150	260
	T4 RCP 42 10 220	5250	3030	140	250	440
LM 180	T4 PFV 43 22 180	6300	3120	185	200	400
	T4 PFV 43 22 280	6300	3120	185	350	715

1) Fy directed to load the two concentric guide rollers

The maximum load is based on the guide roller data (stud and bearing strength) and on maximum contact pressure between rail and roller of 1250 N/mm². Loading is considered to be acting in a single plane or axis only.

BASIC DYNAMIC LOAD OF SINGLE CARRIAGE

The following table shows the nominal load that corresponds to a nominal life of the bearing at 100 km.

The nominal carriage life can be estimated from the standard bearing formula.

$$L_{10} = (C_i / P_i)^3 \times 100 \text{ km}$$

C_i and P_i are the basic capacity and load applied for a specific direction.

Guide	Carriage	Cy (N)	Cz (N)	CMx (Nm)	CMy (Nm)	CMz (Nm)
LM 30	C3 RCL 17 06 065	2800 ²⁾	550	6	11	28
	C4 RCL 17 06 085	2800	1100	12	19	56
LM 40	C3 RCL 24 06 085	7200 ²⁾	1700	24	50	105
	C4 RCL 24 06 114	7200	3400	48	83	210
LM 65	C3 RCL 35 10 115	15800 ²⁾	3350	70	125	300
	C4 RCL 35 10 152	15800	6700	140	210	600
LM 90	C4 RCL 35 10 180	15800	6700	220	250	700
LM 120	T4 RCL 35 10 150	15800	6700	300	330	780
	T4 RCL 35 10 220	15800	6700	300	560	1335
	T4 RCP 42 10 150	24000	11000	500	530	1190
	T4 RCP 42 10 220	24000	11000	500	900	2030
LM 180	T4 PFV 43 22 180	15190	5300	320	335	965
	T4 PFV 43 22 280	15190	5300	320	600	1725

2) Cy directed to load the two concentric guide rollers

CALCULATION EXAMPLE:

FOUR CARRIAGES C3 RCL 35 10 115 PLATFORM

The common configuration is shown in the here following sketch:

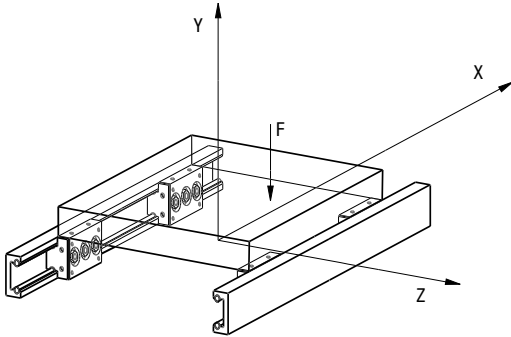

The platform moves along the two guide rails and has a load of “F” acting at 100 mm and 50 mm from the carriage centre.

Data: guide LM 65 and carriages C3 RCL 35 10 115

$$I_x = 400 \text{ mm}$$

$$F = 6000 \text{ N}$$

$$Z_f = 50 \text{ mm}$$

$$I_z = 300 \text{ mm}$$

$$X_f = 100 \text{ mm}$$

In this configuration the load on the most heavily loaded carriage is P_y and can be calculated using the following formula:

$$P = \frac{F}{4} + \frac{F \cdot X_f}{2 \cdot I_x} + \frac{F \cdot Z_f}{2 \cdot I_z} = 2750 \text{ N}$$

The load F_y shown in the “max. loads” table is 4160N (carriages mounted with eccentric roller on top), so that the system is protected against breakage.

To estimate the system life we proceed as follows:
from the nominal life table $C_y = 15800 \text{ N}$

$$L_{10} = (15800 / 2750)^3 \times 100 = 18900 \text{ km}$$

IMPORTANT REMARK

To reach this value it is important to lubricate the rail, otherwise fretting corrosion between rail and roller can reduce the expected life.

U-LINE – PRODUCT DESCRIPTION

AUTO-ALIGNING SYSTEM

Auto-aligning systems are assembled with guide rollers RAL type on LM system carriages tables. The guide rollers RAL type allows axial displacement of the roller on the pin. An “O” ring retains the roller in position during the mounting. Auto-aligning systems compensate for opposite rail misalignment errors. They are useful for mounting inaccurately aligned structures or those structures subject to flexure.

CARRIAGES C3 RAL, C4 RAL, T4 RAL

Is used to compensate for D_x misalignment between opposite rails. The table or carriage with all guide rollers RAL / RALR type can be moved back and forth axially in the direction of the rail. Type RAL provides radial support only. Axial load, transverse to the direction of travel, is reacted by carriage type RCL on the opposite rail.

CARRIAGES C3 RYL, C4 RYL, T4 RYL

Rail misalignment D_y requires the ability for both carriages to rotate. The table or carriage RYL type, with guide rollers RCL / RCP in contact with a steel shaft of the LM rail and guide rollers RALR type in contact with the opposite shaft, allows carriage rotation ensuring at the same time the transverse direction control. The maximum D_y value is dependent on the distance between the rails and the tabulated maximum angle ‘ α ’ for that carriage.

NOTE: RYL carriage axial load capability is lower than the same size RCL / RCP carriage.

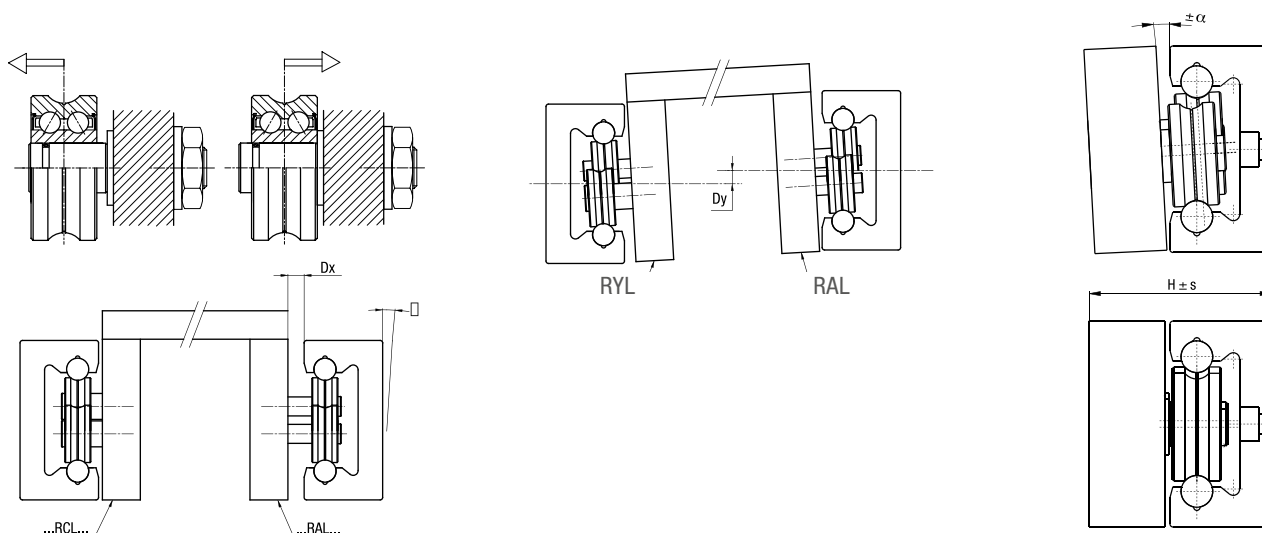

MAX TRANSVERSE MOVING ALLOWED BY AUTO-ALIGNING TABLES AND CARRIAGES

Rail	Carriage code ¹⁾		α max. (°)	S max. (mm)	H nominal (mm)
LM 30	C3 RAL 17 06 065	C4 RAL 17 06 085	1	0.8	27.5
	C3 RYL 17 06 065	C4 RYL 17 06 085	1	–	27.5
LM 40	C3 RAL 24 06 085	C4 RAL 24 06 114	1	1	35.7
	C3 RYL 24 06 085	C4 RYL 24 06 114	1	–	35.7
LM 65	C3 RAL 35 10 115	C4 RAL 35 10 152	1	1	58.0
	C3 RYL 35 10 115	C4 RYL 35 10 152	1	–	58.0
LM 90	–	C4 RAL 35 10 180	1	1	60.5
	–	C4 RYL 35 10 180	1	–	60.5
LM 120	T4 RAL 35 10 150	T4 RAL 35 10 220	0.3	1	58.5
	T4 RYL 35 10 150	T4 RYL 35 10 220	0.3	–	58.5
	T4 RAL 42 10 150	T4 RAL 42 10 220	0.75	1.5	65.5
	T4 RYL 42 10 150	T4 RYL 42 10 220	0.75	–	65.5

¹⁾ See chapter „carriages“ for table and carriage dimensions

Variations of dimension H exceeding $\pm s$ can compromise bearing axial moving and decrease the roller limit load, Fr

LML SYSTEM

Aluminium guide rails LML as well as RCL guide rollers with a plastic-coated outer ring are the components of this line. LML can be used whenever extremely compact dimensions, simple linear motion and an economic solution are required. LML system is suitable for manual and low precision movements, for safety doors, for the adjustment of cameras and sensors and many other products. Applications can be found amongst others in mechanical engineering, medical and food engineering or object monitoring.

MATERIALS, SURFACES, RUNNING CHARACTERISTICS

The guide rail, made of extruded aluminium, has a hard anodised surface. This grey-coloured protective coating ensures a significant protection against wear and corrosion. In addition, it has good tribological characteristics. The guide rollers are made of corrosionresistant bearing steel and their outer rings are coated with a special polyamide material. This material combination contributes to a further improvement of the already known good running characteristics of NADELLA roller guides and makes possible an absolutely low-noise linear motion without any stick-slip.

In contrast to steel to steel combinations, the plastic coating of the guide rollers is slightly flexible and allows higher production tolerances and thus a cost-efficient production.

LOAD RATING AND WORKING LIFE

The carrying capacity of the system is determined by the surface pressure between the plastic coating and the aluminium guide rail. The working life is not calculated.

The following graph applies to the loads indicated in the tables:

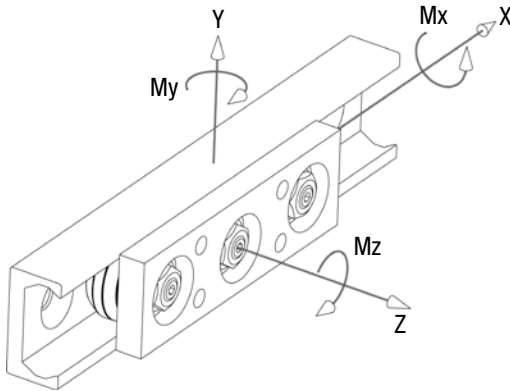

MAXIMUM LOAD ON INDIVIDUAL CARRIAGES

The table below shows the maximum static load that can be applied to an individual carriage for up to 100 hours without leading to permanent deformation of the outer rings. For short stress (< 2 s) and under dynamic load the values can be doubled.

Carriage	Fy (N)	Fz (N)	Mx (Ncm)	My (Ncm)	Mz (Ncm)
C3 RCL 16 NX	150 ²⁾	30	12.5	60	150
C4 RCL 16 NX	150	60	25	95	300

2) Fy with effect on the two concentric rollers

OPTION SLIDING GUIDE

For mostly static applications such as adjusting devices or for non-critical linear movements a suitable polyamide slide with incorporated lubricant is available.

Please contact our application engineers.

U-LINE – LM SYSTEM

GUIDE RAILS LM

Rail composed by an aluminium body and two shafts in steel, with two internal raceways.

Available in stainless steel version.



LM 30

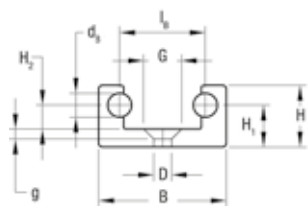

LM 40 / LM 65

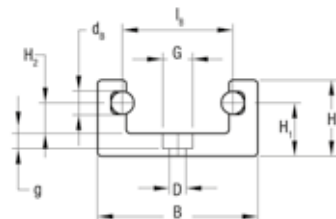

Hole layout for LM 30, LM 40, LM 65

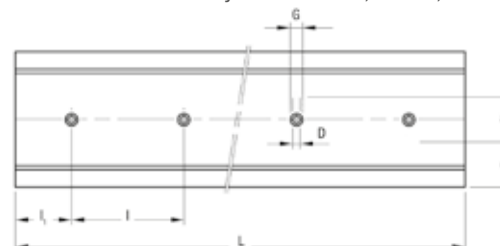

LM 90

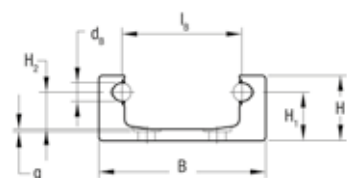

LM 120

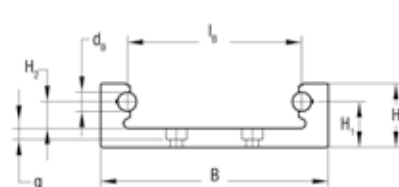

Hole layout for LM 90, LM 120

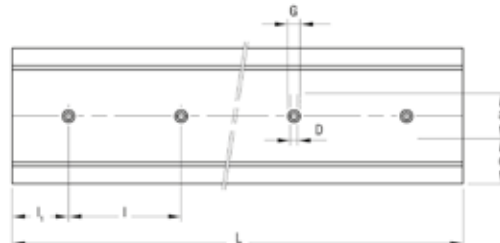

LM 180

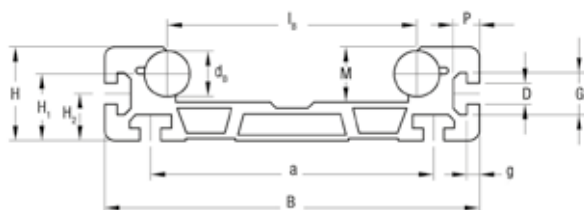

Guide rail	Hole layout
LM 30, LM 40, LM 65	Linear
LM 90, LM 120	Chevron
LM 120	No holes

Type	Dimensions (mm)														Moments of inertia ³⁾ (cm ⁴)		Weight (kg/m)	L max. ⁴⁾ (mm)	
	d _B	l _B	B	H	H ₁	H ₂	M	D	G	g	a	e	P	l	l ₁	J _x			J _y
LM 30 ¹⁾	6	21.5	32	15.5	10.5	6	11	4.5	9.5	2.5	–	16	–	80	40	0.5	3	1.1	6000
LM 40 ¹⁾	6	29	42	20	14	8	14	4.5	8	4	–	21	–	100	50	1.2	8.8	1.5	6000
LM 65 ¹⁾	10	42.5	65	32	23.5	13.5	22	6.5	11	6	–	32.5	–	100	50	8.8	54.9	4.1	6000
LM 90 ¹⁾	10	65	90	35	26	20	29	9	15	0.5	38	26	–	100	50	16.4	160.2	4.7	6000
LM 120 ¹⁾	10	92	120	33.5	24	14	23.5	6.5	11	6	40	40	–	100	50	14.8	311.6	6	6000
LM 180	22	120	180	45	32	22.5	26.5	10 ²⁾	20.1 ²⁾	6	136	–	12.5	–	–	53.3	1096.6	13.1	6000

1) Available with stainless steel shafts (suffix NX)

2) Slot for nut DIN 508

3) Inertia value based on equivalent aluminium yield 70000 N/mm² complete with guide rod

4) Longer rails are supplied in sections with ground butt joints and, on request, with pin connection

HOLE LAYOUT

- Holes according to catalogue (SB)
- Finishes to drawing (NZ)
- Without holes (NF)

OPTIONAL FEATURES

- Ground one end: side of the first hole (1R), side of the last hole (2R)
- Ground both ends (RR)
- Chromium plated shafts (CH)
- Stainless steel shafts (NX)
- Pin based shaft connection (G)

Example of standard designation: LM 40 1720 NF

GUIDE ROLLERS RCL, RCP, PFV

PFV: Guide roller with gothic arch profile, based on ball bearing.

RCL / RCP: Guide roller with gothic arch profile, based on angular contact ball bearing.

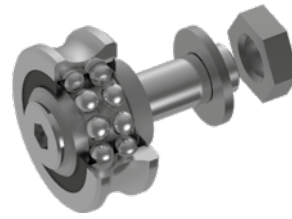

Available in stainless steel version.



RCL / RCP

CONCENTRIC

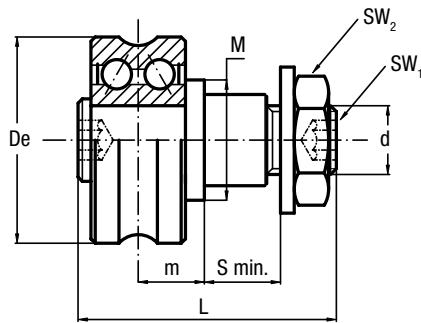

PFV

CONCENTRIC

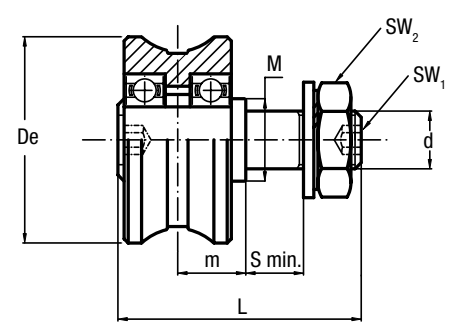

ECCENTRIC

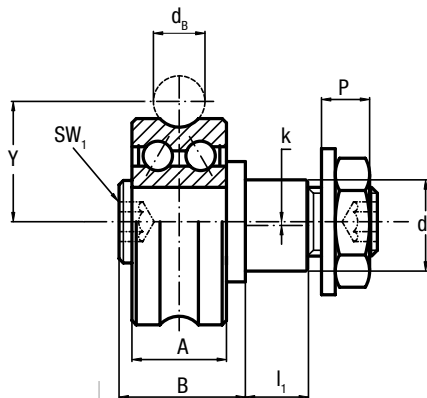

ECCENTRIC

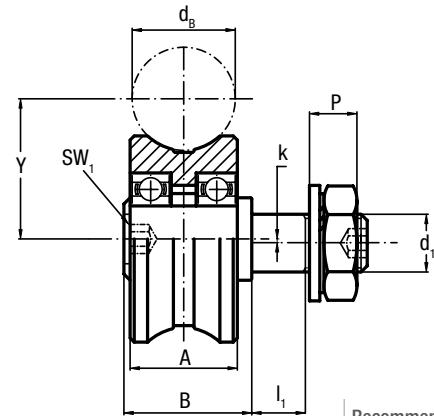

Type

Dimensions (mm)

Recommended pairings

concentric	eccentric	De	dB	d ₁ ²⁾ conc.	d ₁ ²⁾ ecc.	d	Y	m	S min.	P	L	A	B	I ₁	M	SW ₁	SW ₂	k	
RCL 17.06 ¹⁾	RCLR 17.06 ¹⁾	17	6	5	6.5	M5x0.8	10.5	6	6	3.7	21	7	11	5.2	9	2.5	8	0.25	LM 30
RCL 24.06 ¹⁾	RCLR 24.06 ¹⁾	24	6	8	11	M8x1.25	14	7.7	7	5.6	28.2	11	14.7	6.5	14	4	13	0.5	LM 40
RCL 35.10 ¹⁾	RCLR 35.10 ¹⁾	35	10	10	10	M10x1.25	20.65	10.5	14	7	43	15.9	20.5	13	18	5	17	0.75	LM 65
RCP 42.10	RCPR 42.10	42	10	17	17	M12x1.25	24	12.5	12	9.5	50	19	24.5	11	25	6	19	0.75	LM 120
PFV 43.22 ¹⁾	PFVR 43.22 ¹⁾	43	22	12	12	M12x1.5	29	14	13	12.5	52	23	27	12	18	5	19	1	LM 180

1) Available in stainless steel (suffix NX)

2) Housing bore tolerance: H7

Type	Dynamic load (N)	Limit loads (N)	Life coefficients	Torque wrench settings ⁴⁾ (Nm)	Weight (g)			
concentric	eccentric	Radial F _r	Axial F _a	X	Y			
RCL 17.06	RCLR 17.06	1400	530	150	1	3.28	3	20
RCL 24.06	RCLR 24.06	3600	1600	460	1	2.52	8	40
RCL 35.10	RCLR 35.10	7800	2400	650	1	2.93	20	130
RCP 42.10	RCPR 42.10	12000	4300	1100	1	2.73	24	185
PFV 43.22	PFVR 43.22	7600	3150	750	1	4	26	205

3) C_w basic load for 100 km

4) The torque wrench settings are given for non-lubricated threads; for lubricated threads, multiply figure by 0.8

- The guide rollers are complete with self-locking washers and hexagonal nut (DIN 439B) for fitting

- Pressure angle α for load calculation: 60°
- Standard shields ZZ type for RCL and RCP; NBR seals type RS for PFV

U-LINE – LM SYSTEM

GUIDE ROLLERS RAL

Floating guide rollers with “gothic arch” profile, with a double row of balls with oblique contact.

Available in stainless steel version.

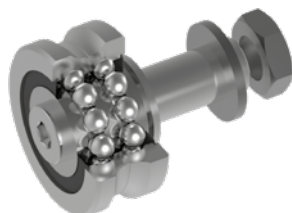

CONCENTRIC

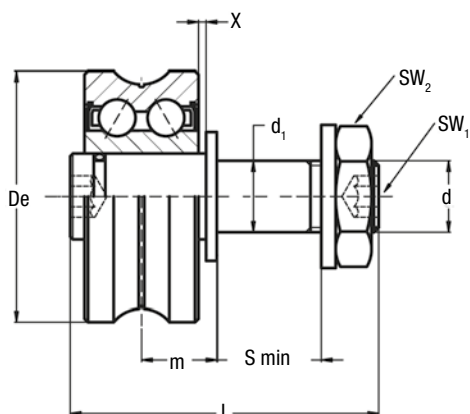

ECCENTRIC

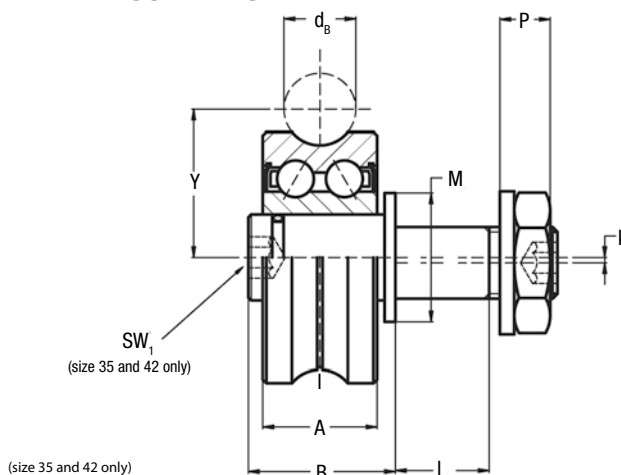

Type		Dimensions (mm)																		Suggested combinations
concentric	eccentric	De	db	d ₁ ²⁾ conc.	d ₁ ²⁾ ecc.	d	Y	m min. ³⁾	m max. ³⁾	S min.	P	L	A	B	I ₁	M	SW ₁	SW ₂	k	
RAL 17.06 ¹⁾	RALR 17.06 ¹⁾	17	6	5	6.5	M5x0.8	10.5	6	7.6	6	3.7	20.5	7	10.5	5.2	9	2.5	8	0.25	LM 30
RAL 24.06 ¹⁾	RALR 24.06 ¹⁾	24	6	8	11	M8x1.25	14	7.7	9.7	7	5.6	27.5	11	14	6.5	14	4	13	0.5	LM 40
RAL 35.10 ¹⁾	RALR 35.10 ¹⁾	35	10	10	10	M10x1.25	20.65	10.5	12.5	14	7	43	15.9	20.5	13	18	5	17	0.75	LM 65
RAL 42.10	RALR 42.10	42	10	17	17	M12x1.25	24	12.5	15.5	12	9.5	49	19	23.5	11	25	6	19	0.75	LM 120

1) Available in stainless steel (suffix NX), seals in nitrile rubber type RS

2) Housing bore tolerance: H7

3) To ensure a safe and proper functioning the dimension m must not be higher than m max

Type		Dynamic load (N)	Limit load (N)	Torque wrench settings ⁵⁾ (Nm)	Weight (g)
concentric	eccentric	C _w ⁴⁾	Radial F _r		
RAL 17.06	RALR 17.06	1400	450	3	20
RAL 24.06	RALR 24.06	3600	1400	8	40
RAL 35.10	RALR 35.10	7800	2100	20	130
RAL 42.10	RALR 42.10	12000	3400	24	185

4) C_w basic load for 100 km

5) The torque wrench settings are given for non-lubricated threads; for lubricated threads, multiply figure by 0.8

- The guide rollers are complete with self-locking washers and hexagonal nut for fitting
- Standard shields ZZ type

GUIDE WHEELS GLA

Guide wheel with double row of balls with oblique contact, with "gothic arch".

Available in stainless steel version.

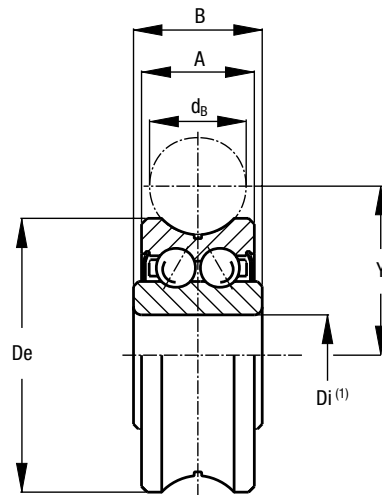
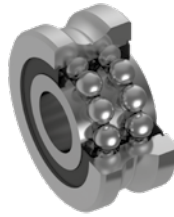

Type	Dimensions (mm)					
	De	d _B	D _i ²⁾	Y	A	B
GLA 17.06 ¹⁾	17	6	5	10.5	7	8
GLA 24.06 ¹⁾	24	6	8	14	11	11
GLA 35.10 ¹⁾	35	10	12	20.65	15.9	15.9
GLA 35.12	35	12	12	21.75	15.9	15.9
GLA 42.10	42	10	12	24	19	19
GLA 47.10	47	10	15	26.65	19	19
GLA 52.16	52	16	20	31.5	20.6	22.6

1) Available in stainless steel (suffix NX)

2) Tolerance of diameter D_i: +0 / -0.008 mm

Type	Dynamic load (N)	Limit loads (N)		Life coefficients		Weight (g)
	C _w ³⁾	Radial C _{or}	Axial C _{oa}	X	Y	
GLA 17.06	1400	840	200	1	3.28	10
GLA 24.06	3600	2300	600	1	2.52	20
GLA 35.10	7800	4600	1200	1	2.93	80
GLA 35.12	7800	4600	1200	1	2.93	80
GLA 42.10	12000	6900	2100	1	2.73	100
GLA 47.10	14000	7900	2500	1	2.61	170
GLA 52.16	19000	10500	3300	1	2.73	230

3) C_w basic load for 100 km

- Pressure angle α for load calculation: 60°
- Standard shields ZZ type (GLA 52.16 with RS seals type)

U-LINE – LM SYSTEM

CARRIAGE C3 RCL, C3 RAL, C3 RYL

Carriage with body in anodised aluminium with 3 guide rollers.

Available in stainless steel version.

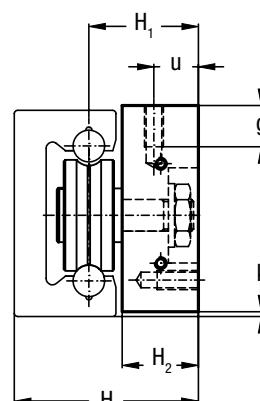
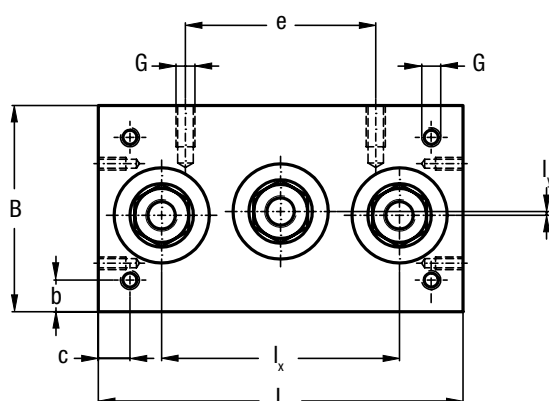

Type	Dimensions (mm)														Weight (kg)	Recommended pairings
	L	B	I _x	I _y	H	H ₁	H ₂	G	g	b	c	u	e	k		
C3 RCL 17 06 065	65	32	40	0.5	27.5	17	11	M4	6	4	6	5.5	24	0.5	0.1	LM 30
C3 RCL 24 06 085	85	42	58	1	35.7	21.7	14	M5	8	6	6	7	35	1	0.2	LM 40
C3 RCL 35 10 115	115	65	75	1.2	58	34.5	24	M6	10	10	10	14	60	1.5	0.8	LM 65

- Dimensions in the table are correct also for carriages C3 RAL, C3 RYL
- Available with stainless steel guide rollers (suffix NX)

CARRIAGE C4 RCL, C4 RAL, C4 RYL

Carriage with body in anodised aluminium with 4 guide rollers.

Available in stainless steel version.

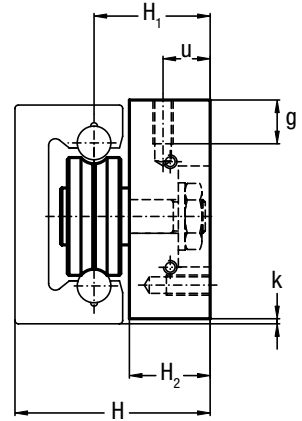
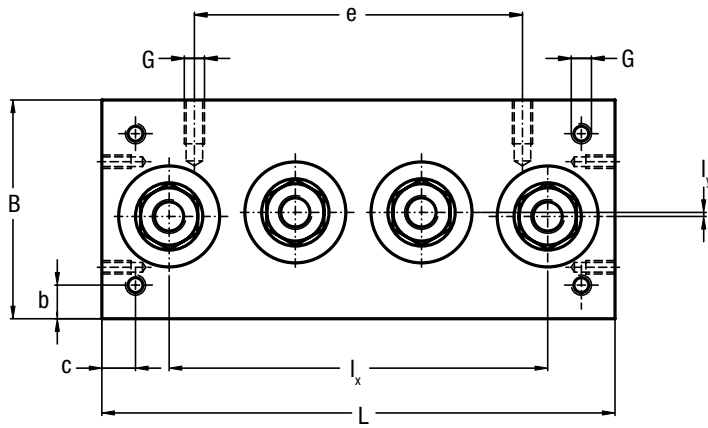

Type	Dimensions (mm)														Weight (kg)	Recommended pairings
	L	B	I _x	I _y	H	H ₁	H ₂	G	g	b	c	u	e	k		
C4 RCL 17 06 085	85	32	60	0.5	27.5	17	11	M4	6	4	6	5.5	44	0.5	0.15	LM 30
C4 RCL 24 06 114	114	42	87	1	35.7	21.7	14	M5	8	6	6	7	60	1	0.25	LM 40
C4 RCL 35 10 152	152	65	112.5	1.2	58	34.5	24	M6	10	10	10	14	90	1.5	1	LM 65
C4 RCL 35 10 180	180	90	135	23.7	60.5	34.5	24	M6	10	10	10	14	120	2	1.5	LM 90

- Dimensions in the table are correct also for carriages C4 RAL and C4 RYL
- Available with stainless steel guide rollers (suffix NX)

U-LINE – LM SYSTEM

CARRIAGE T4 RCL, T4 RCP, T4 PFV, T4 RAL, T4 RYL

Carriages with anodised aluminium body with four guide rollers with “gothic arch” profile.



T4 RCL
T4 RCP

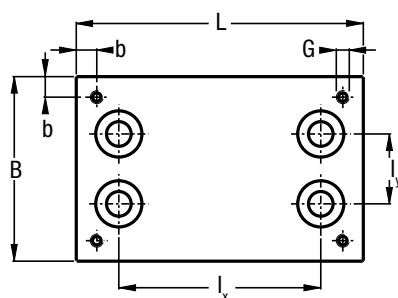

T4 PFV

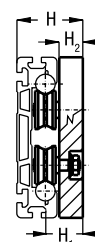
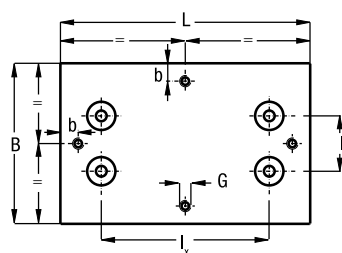
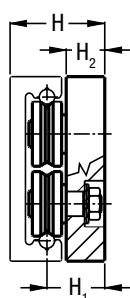

Type	Dimensions (mm)									Weight (kg)	Recommended pairings
	L	B	I _x	I _y	H	H ₁	H ₂	G	b		
T4 RCL 35 10 150	150	120	99	50.7	58.5	34.5	24	M8	10	1.6	LM 120
T4 RCL 35 10 220	220	120	169	50.7	58.5	34.5	24	M8	10	2.2	LM 120
T4 RCP 42 10 150	150	120	99	44	65.5	41.5	29	M8	15	2	LM 120
T4 RCP 42 10 220	220	120	169	44	65.5	41.5	29	M8	15	2.7	LM 120
T4 PFV 43 22 180	180	180	127	62	74	42	28	M10	20	3.1	LM 180
T4 PFV 43 22 280	280	180	227	62	74	42	28	M10	20	4.5	LM 180

- Dimensions valid also for T4 RAL and T4 RYL

LUBRICATOR LUBM

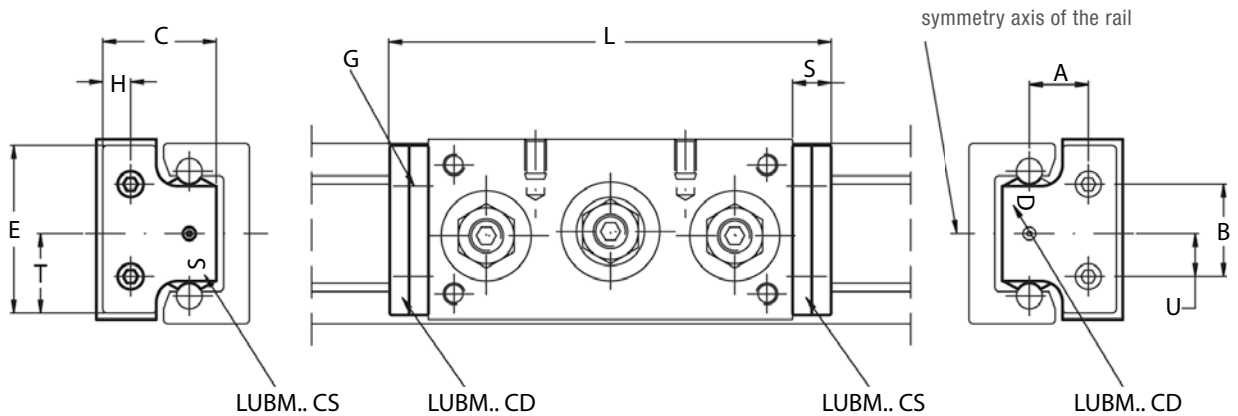
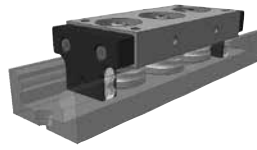

Type	Dimensions (mm)											Recommended pairings
	A	B	U	E	T	H	C	G ¹⁾	S	L C3 RCL	L C4 RCL	
LUBM 030	9.5	16	8	30	15	6.5	20.5	M2.5	9	83	103	LM 30
LUBM 040 CD / CS	13.7	21.5	10	40	19	7	27	M3	9	103	132	LM 40
LUBM 065 CD / CS	20.5	30	15	63	30	13	44.5	M4	9	133	170	LM 65

1) One lubricator for packaging. Countersunk head screws for the mounting are already in the packaging

- The lubricator is supplied with the felt already lubricated. The lubricant has a mineral oil base
- The lubricator can be mounted on carriages RCL, RAL and RYL

OPTIONAL FEATURES

- Felt without lubricant (D)

U-LINE – LM SYSTEM

GUIDE RAILS LML

Rail totally in aluminium with two internal raceways.

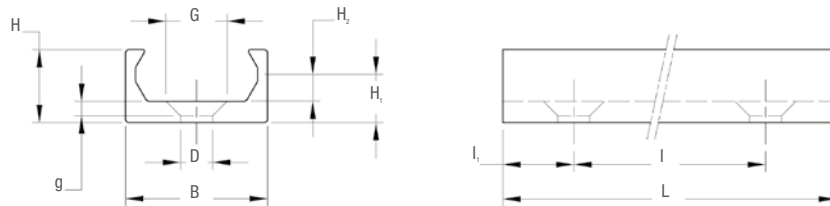
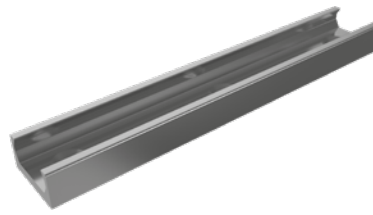

Type	Dimensions (mm)										Moments of inertia (cm)		Weight (kg/m)	L max. (mm)
	B	H	H ₁	H ₂	D	G	g	I	I ₁	J _x	J _y			
LML 20	20	10.3	6.8	3.8	4.5	9.5	2.5	80	40	0.068	0.427	0.235	2800	

Surface hard anodised

HOLE LAYOUT

- Holes according to catalogue (SB)
- Holes according to drawing (NZ)
- Without holes (NF)

Example standard rail: LML 20 1200 SB

CARRIAGE C3 RCL 16 NX

Carriages with 3 anti-corrosion rollers covered in plastic for guides LML 20.

Available in stainless steel version.

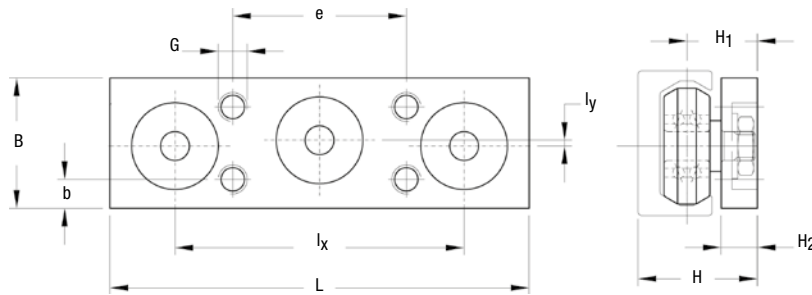

Type	Dimensions (mm)										Weight (g)
	L	B	l_x	l_y	H	H_1	H_2	G	b	e	
C3 RCL 16 NX	58	18	40	0.8	16.5	9.75	5	M4	4	24	33

CARRIAGE C4 RCL 16 NX

Carriages with 4 anti-corrosion rollers covered in plastic for guides LML 20.

Available in stainless steel version.

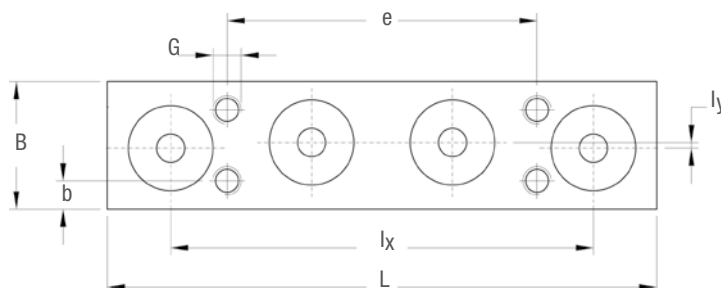
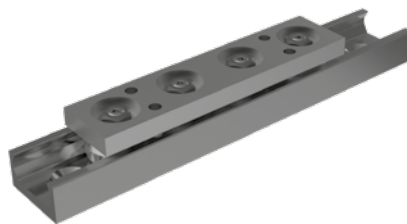

Type	Dimensions (mm)										Weight (g)
	L	B	l_x	l_y	H	H_1	H_2	G	b	e	
C4 RCL 16 NX	78	18	60	0.8	16.5	9.75	5	M4	4	44	44

U-LINE MOUNTING EXAMPLE

Protective doors on machine tool
U-Line

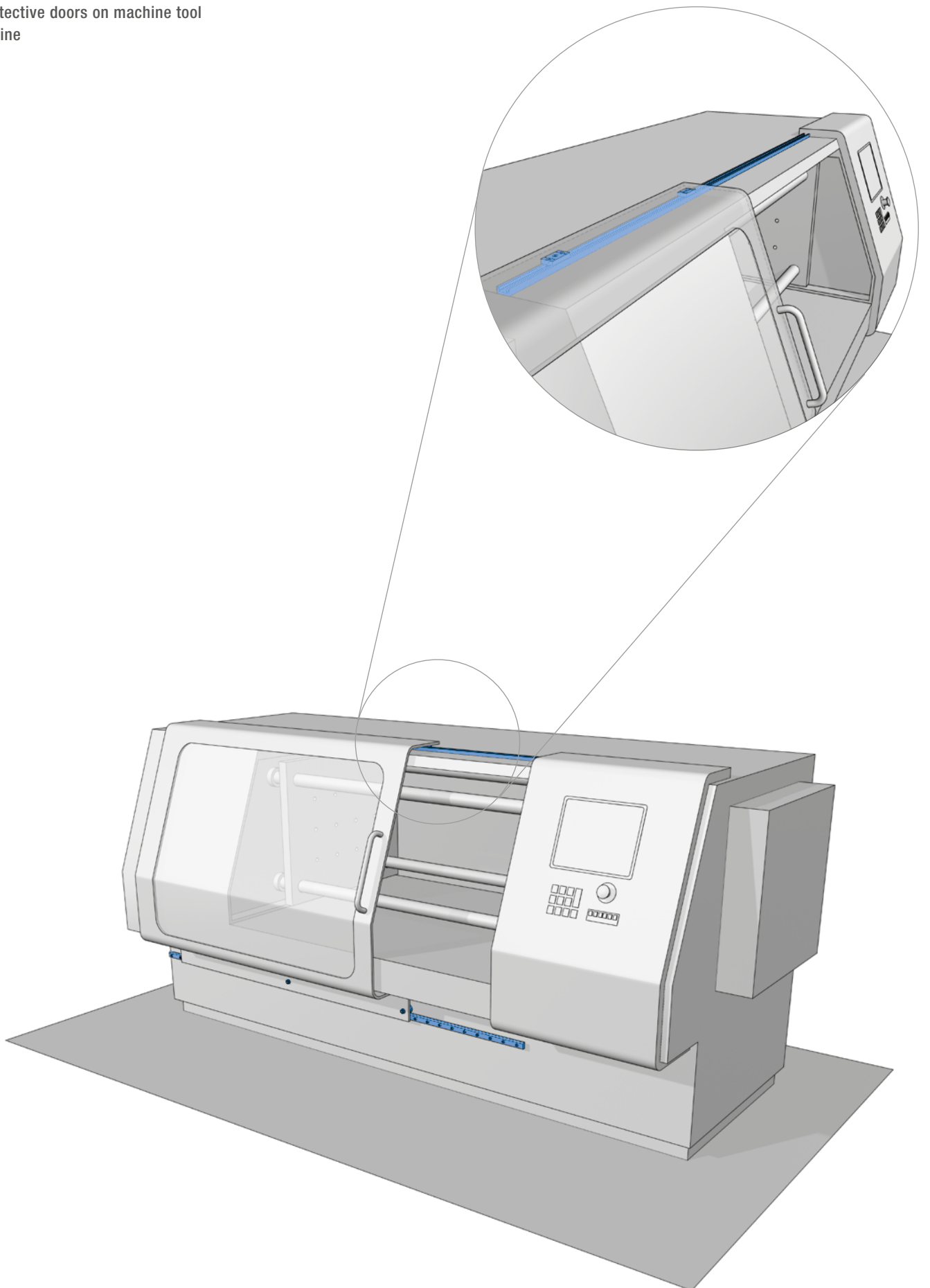



TECHNICAL FEATURES

PAGE 148

11.1 NADELLA LINEAR SYSTEMS

- Guides
- Aluminium guides
- Guide rollers
- Lubrication
- Assembly instructions
- Calculation procedure
- Examples of calculation

PAGE 156

11.2 GUIDE RAIL ORDER CODE

PAGE 157

11.3 PRODUCT INDEX

PAGE 159

11.4 SUFFIX INDEX

TECHNICAL FEATURES

NADELLA LINEAR SYSTEMS

With this line of products, NADELLA confirms the aim to provide manufacturing solutions tailored to the user's needs in order to achieve simple automation at a low cost. The process under way of transferring production automation and relevant handling onto increasingly heavier and cumbersome units has prompted us to seek original and flexible components for the different commodity sectors.

We have accumulated sound working experience in the following sectors:

- Marble-working machinery
- Foundry machinery
- Metal sheet working machinery
- Special lifting machines
- Pick up
- Automatic warehouses
- Textile machines
- Machine tool protections and utilities
- Oxygen cutting machines

Our Technical Department works with Customers and recommends the best component choice by making the calculations needed to determine the best life.

GUIDES

LENGTH

The maximum length of each single guide component is shown on the dimensional tables. The standard lengths of the rails are determined by adding the product of the fixing hole centre distance and the number of holes to twice the end dimension (see dimensional tables).

Length	≥ 150 < 420	≥ 420 < 1050	≥ 1050 < 2040	≥ 2040 < 4020	≥ 4020
Length tolerance	± 0,5	± 0,8	± 1,2	± 2	± 2,5

JOINTS

For strokes of greater length, the guide components can be joined after grinding the end faces (suffix R or RR). To maintain the hole centre distance tolerance, when ordering always specify the number of individual rails making one continuous length. Please specify in the order when rails have to be matched. The junctions are marked (letters and numbers) to avoid a mix-up of different rails.

FIXING HOLES

The guides are available with standard holes, as shown in dimensional tables, with special hole layout or without holes (see order code referencing) Standard tolerance for hole position is ± 0,25 mm.

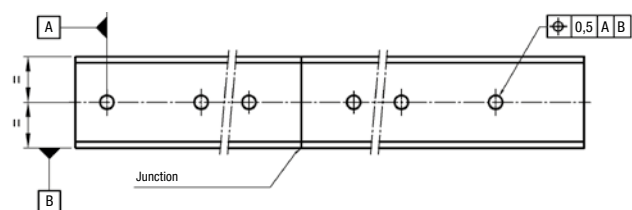

The standard boring layout is designed to fit most common application requirements, but connection strength has to be evaluated on the application case.

STEEL GUIDES

GENERAL

Steel rails are made of bearing steel to give best stability and durability. Raceways are induction hardened to achieve 58 HRC hardness minimum. The rail core remains soft to allow easy machining. Rails can be provided with different finishes to meet specific application requirements.

- Guide rails MT type: Profile is produced by cold drawing process, raceways are induction hardened and sandblasted to improve surface strength and finish.
- Guide rails M type: Profile is usually produced by cold drawing process, induction hardened on raceways and ground to improve surface finish and profile geometry and to remove the partially decarburised surface (0.1 mm max. on cold drawn rails ... MT). Ground rails have to be used when there are high loads, heavy duty cycles or when there is a high accuracy requirement.
- Guide rails MC type (flat rail GP ... MC only): MC rails are induction-hardened on every side and finished by-a-rough grinding.

OPTIONS

Corrosion protection

For use in oxidising environments or in the presence of corrosive agents, the guides are available with chemical nickel-plating protective anticorrosion treatment (suffix NW). This treatment features substantial mechanical characteristics together with a resistance to salty mist corrosion superior to that of hard chrome. On request many rails are available in stainless-steel version (suffix NX) **NX**. On request can be supplied rails with different surface treatment, as chrome plating and phosphating. Rails LS are supplied with a standard surface treatment of zinc plating (suffix GZ). A wide range of stainless steel rails is available (suffix NX).

CIRCULAR RAIL

On request circular rails can be provided. Circular rails can be used as an alternative to rotating devices or as junction between straight rails.

TECHNICAL FEATURES

Standard rail straightness (for non-mounted rails) is 0.5 mm/m max. Higher accuracy can be supplied on request.

TEMPERATURE

Standard operating temperature range is -20°C up to 150°C. In lower or higher temperature applications please contact NADELLA Technical Service. Special care is required if guide rollers are operating at maximum temperature.

ALUMINUM GUIDES

GENERAL

Made by joining an aluminium alloy support element and hardened steel rods that form the sliding surfaces. The best features of the two materials and relevant working technologies are combined to give the lightness of the alloy and the hardness and surface finish of the rods. Guides of this type can be used for structural functions; they have a high moment of inertia that enables them to be used in many applications as carrying structures. Aluminium extruded profiles are stabilised and anodised. Sliding rods are induction hardened and ground.

OPTIONS

Corrosion protection



For use in oxidising environments or in the presence of corrosive agents, the guides of this series can feature stainless-steel bars (suffix NX).

Chromium-plated rods

Optionally chromium-plated rods are available (suffix CH); the thickness of the chromium plating is $10 \pm 5 \mu\text{m}$ with hardness ≥ 800 HV. Please check option availability in dimensional tables.

JOINTS

In case rail made by multiple C-DC or LM rails the most efficient joint can be realized with the insertion of a dowel pin inside the rods. This solution allows for simple assembly at the site and maintains alignment under load.

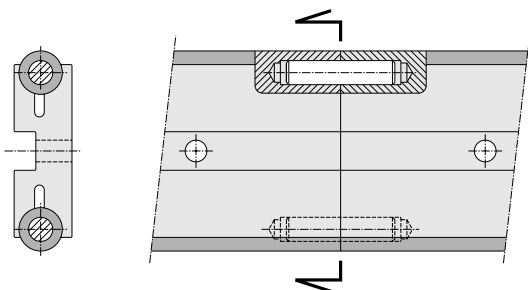

For rails FWS/FWN the joint can be realised by protruding the rods of one rail in order to engage them in the profile of the next rail. There will be a small gap between the aluminium profiles. The steel shafts are joined without gap.

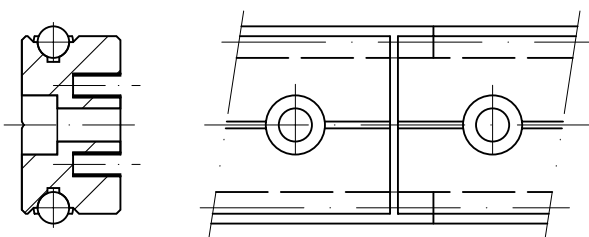

TECHNICAL FEATURES

Standard rails' straightness (for non mounted rails) is 0.5 mm/m maximum. Higher accuracy can be supplied on request.

TEMPERATURE

Standard operating temperature range is -20°C up to 70°C . Applications with frequent temperature variation should be avoided. For operating conditions outside the given range please contact NADELLA Technical Service.

GUIDE ROLLERS

GENERAL

NADELLA provide a wide range of guide rollers to be able to meet different technical and economic requirements. All guide rollers are produced in concentric and eccentric versions to allow backlash adjustment during assembly on final equipment. Eccentric rollers are identified by additional R in the code.

The sides of the races of the guide roller are slightly convex. Besides reducing rolling friction, this also permits offsetting slight guide flexing or small assembly alignment errors.

Guide rollers are fitted with seals or shields for bearing protection and lubricant retention as described in dimensional tables.

Guide rollers based on needle or tapered roller bearings (FRN ... EI, RK ..., PK ...) are recommended for critical applications with heavy axial loads and / or shock loading. Guide rollers based on ball bearings (FR ... EU, PFV, RCL) are more suitable for lighter loads or high dynamic systems.

The carriages based on Rolbloc's system are recommended for applications with heavy loads, high frequency of work and aggressive environment (dust, abrasive).

When mounting guide rails opposite to each other with connected carriages, as shown in the next sketch, a high level of parallelism between the guide rails is required when axially rigid rollers are used. To avoid operating problems it is recommended to use axially rigid fixed rollers on one carriage e.g. FR ... EU / FRR ... EU and axially movable rollers on the other carriage e.g. FRL ... EU / FRLR ... EU. Movable rollers allow a little misalignment between the opposite mounted guide rails.

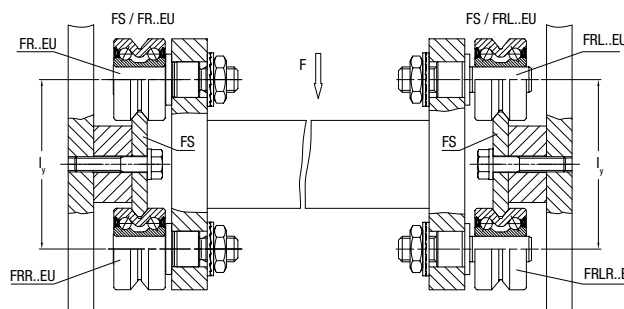

Another solution is to use one profiled guide rail e.g. FS and on the opposite side a flat rail e.g. GP in connection with rollers GC or PK.

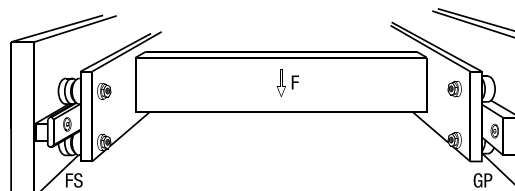

TECHNICAL FEATURES

NADELLA LINEAR SYSTEMS

TECHNICAL FEATURES

Lubrication

Guide roller FRN ... EI, GC, FG permits bearing relubrication. All other guide rollers are long life lubricated.

Temperature

Guide roller should not operate at constant temperature above 80°C. For short durations 100°C can be accepted. For higher temperature please see the "option section".

Speed limit

Max. velocity has to be determined for each application relevant to the guide roller type, size and load conditions. As general value, in normal conditions maximum speed is 4 m/sec but, with the correct choice of the components, the speed can reach 10 m/s. Contact NADELLA Technical service in case of specific request.

OPTIONS

Corrosion protection

NX For use in oxidising environments or in the presence of corrosive agents, the guide rollers are available in stainless steel (suffix NX) the guide rollers with tapered rollers (RKU, RKY / X, FKU, FKY / X) and needles (FRN) are equipped with standard bearings. Check in the dimensional table component availability.

High temperature

On request guide rollers can be equipped with Viton seals to operate at temperatures up to 120°C (suffix V). Check in the dimensional table component availability.

ACCESSORIES

Tables and carriages

Standard table and carriages for C-, DC- and LM-systems incorporate a black anodised aluminium plate fitted with guide rollers.

Wipers

Standard wipers NAID for C-, DC-rails are made from NBR compound moulded on a steel plate.

Lubricators

Are composed by two main parts: a plastic box with the same shape profile of the rail, and a lubricated felt; the felt is slightly pressed on the raceways by a spring. The plastic box, that drags the raceways, works as a wiper, and removes dust and shavings.

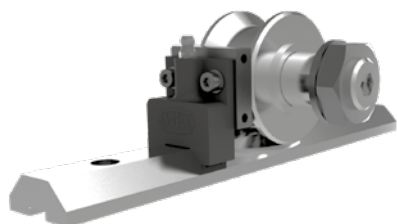

The plastic box can be mounted directly on the guide rollers plate by the appropriate aluminium plate included in the kit. In the lubricators for guide rollers size 52 or higher, the grease nipple allows an easy connection with a re-lubrication system. For the lubrication of the rails you can use one lubricator only on each raceway; in order to wipe the

raceways it is better to mount two lubricators, before and after the carriage. The lubricators are supplied with the felt already lubricated.

USE IN DIRTY ENVIRONMENT

Due to the design cam rollers with profile are especially adapted to the use in rough and dirty environment. This property has proved true in many applications such as welding plants, steel and grinding machines and is superior to recirculating ball bearing guides in continuous operation.



LUBRICATION

BEARING LUBRICATION

All the guide rollers, except for the FRN ... EI, based on needle bearings, are equipped with long life lubricated bearings. This means that the grease inside the bearing is enough for the entire life of the roller guide. The roller guide type FRN ... EI, with needle bearings, accommodates the re-lubrication of the bearings.

Rail lubrication

Rails must be lubricated. This allows to reduce the friction, to reach the calculated lifetime of the system and to work at high speed. No or insufficient lubrication will cause rapid deterioration. The typical signal of tribocorrosion is the presence of a red / dark oxide and rapid wearing of the rail and guide rollers. The lubrication of the rail, the working environment and the load must be considered all together for a correct estimation of the lifetime of the guide system.

Generally speaking, for application with low duty frequency, a periodic re-lubrication with a grease or with a viscous oil will sufficiently maintain the lubrication film. The re-lubrication interval depends on the application and must always be tested in the real working conditions. In a system with ground rails and short stroke without lubricators, you can consider a re-lubrication interval every 100,000 cycles. Increasing the load, speed or stroke, or using an undersized bearing will increase lubrication demand and result in a shorter lubrication interval. For a constant lubrication we suggest the use of felt lubricators to ensure a constant layer of lubricant between guide rollers and raceways. Felt lubricators enlarge the lubrication interval more than ten times.

The recommended lubricants are greases and oil for bearings, linear rails or chains, with a high viscosity of the basic oil and with EP additives, in order to separate the metallic surfaces even with low speed.

ASSEMBLY INSTRUCTIONS

GUIDE ROLLERS

The eccentric guide rollers allow the preload or clearance of the carriage to be adjusted independently of the guide roller mounting hole positioning tolerance or the distance between the rails. Recommended mounting hole tolerance is H7. When adjusting the eccentric guide roller care has to be taken to avoid excessive preload. Excessive preload can reduce the life of the linear system. Set the preload turning the guide roller counterclockwise so that any movement caused by vibration will cause the nut to be tightened. Ensure the preload is not increased when tightening the nut.

A simple way of setting a roller preload is as follows:

- Move the slider on the guide, holding the roller being adjusted with two fingers to prevent it from rotating
- Increase the preload by means of the wrench
- Repeat step 1 making sure the roller slides without rolling
- When it is no longer possible to prevent roller rolling, slightly decrease the preload and fully tighten the lock nut, thereby setting the position of the eccentric.

GUIDES

For single guide rail type FS, FWS, LS, DC, FWN and LM no special assembly instructions are necessary. For multiple parallel rails parallelism has to be checked to avoid guide rollers overload or excessive carriage play. When constant preload is required parallelism error has to be lower than 0.050 mm.

Connection between the rail and the mounting surface has to be designed accordingly with the operating condition to ensure proper product positioning and functionality. The direction and intensity of the load, the number and strength of the screws, the geometry of mounting surfaces, use of pins or wedges have to be evaluated to fully utilize the linear guide load capacity.

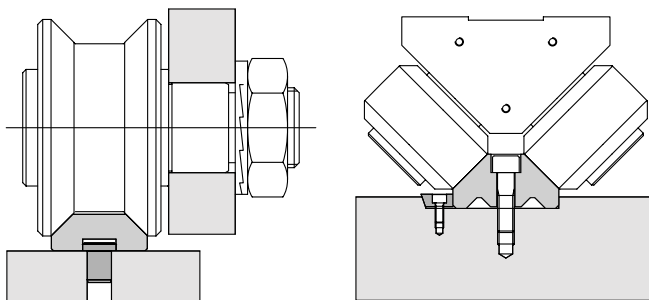

CARRIAGES

Carriages are supplied with concentric guide rollers nut tightened already. Eccentric guide rollers have to be set and tightened during final assembly operation by customer.

CALCULATION PROCEDURE

Calculation is carried out in two steps, first defining the forces on the most heavily loaded roller and then estimating the safety factors and

life.

CALCULATING THE LOADS ON THE GUIDE ROLLERS

In the case of complex load situations, with forces acting in different directions, calculating the reactions on the rollers is difficult and hard to simplify. In the event of the applied load having a direction parallel to one of the co-ordinate axes, the radial P_r and axial P_a components of the reactions on the most loaded roller can be obtained using elementary formulas. With reference to the diagrams shown, we obtain the load components on the rollers relevant for checking and calculating the life, applying the following methods.

Angle α in the formulas is half the groove angle. Look in the dimensional table notes for the correct value.

Distance l_c is the effective contact distance. With the exception of Rol-bloc system the correct value is calculated as the guide roller centre distance across the rail plus or minus the outer guide roller diameter D_e , depending if the guide is outside or between the rollers.

Guides between the rollers

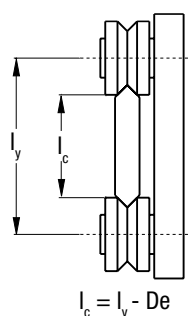

Guides outside the rollers

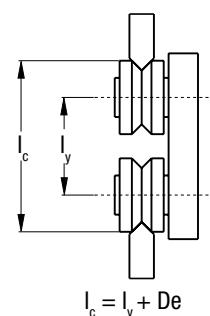

In case of Rolbloc the distance l_c is the distance between the rails basis.

Diagram a)

Load F applied parallel to axis Y

Guide between the rollers

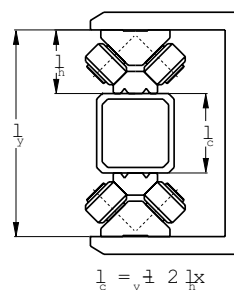

Guides outside the rollers

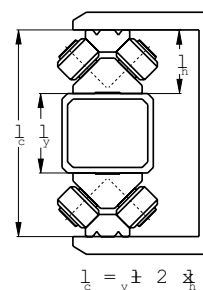

TECHNICAL FEATURES

NADELLA LINEAR SYSTEMS

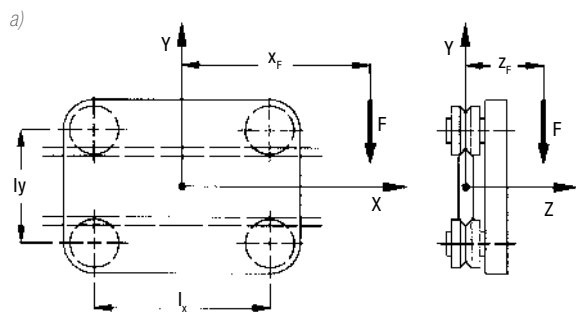

$$P_a = \frac{F_1 \cdot \Delta_z}{2 \cdot l_x}$$

$$P_r = \frac{F_1}{l_x} \cdot \left(\frac{\Delta_z \cdot \tan \alpha}{2} + \Delta_y \right)$$

GUIDE ROLLER CALCULATION

In the table for each roller the following data is specified:

- C_w basic dynamic load, it is the radial load (N) that applied to the guide roller gives 100 km nominal life.
- F_r limit radial load, it is the maximum radial load (N) that can be applied on the guide roller; guide roller considering the strength of the stud.
- F_a limit axial load, it is the maximum axial load (N) that can be applied on the guide roller; guide roller considering the strength of the stud.
- X and Y coefficients to define the equivalent load for bearing life.
- α is the contact angle dependent on the guide roller type.

$$P_a = \frac{F \cdot z_F}{2 \cdot l_c}$$

$$P_r = \frac{F \cdot (l_x + 2 \cdot x_F)}{2 \cdot l_x} + \frac{F \cdot z_F \cdot \tan \alpha}{2 \cdot l_c}$$

Diagram c)
Load F applied parallel to axis X

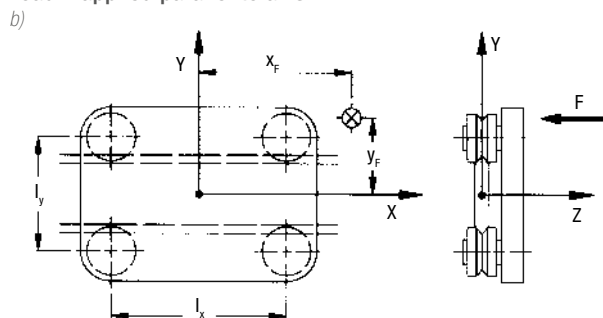

Rollers FRN ... EI work as combined bearings, the basic dynamic load is defined as:

- C_{wr} basic radial dynamic load, it is the radial load (N) that applied to the guide roller gives 100 km nominal life.
- C_{wa} basic axial dynamic load, it is the axial load (N) that applied to the guide roller gives 100 km nominal life.

Note: ISO 281 states 'the nominal life will be exceeded by 90 % of bearings before the first sign of material fatigue'.

$$P_a = \frac{F}{4} + \frac{F \cdot x_F}{2 \cdot l_x} + \frac{F \cdot y_F}{2 \cdot l_c}$$

$$P_r = P_a \cdot \tan \alpha$$

NOMINAL LIFE CALCULATION

System life is the minimum life of either the bearings in the guide roller or the rail / roller contact surfaces.

For the rail / roller surface see the lubrication paragraph. For the bearings' life proceed as follows.

Diagram c)
Carico F applicato parallelo all'asse X

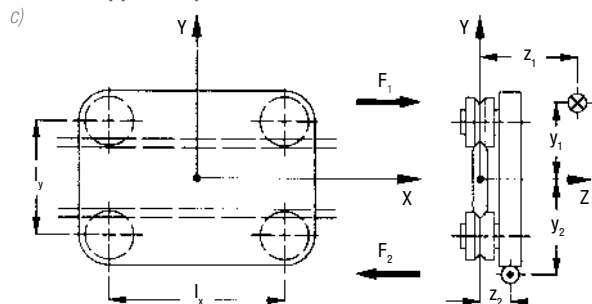

The loads P_r and P_a are calculated for ideal condition. However, in practice, because of the structure and operating conditions a better calculation and life estimation is performed using overload factor f_w as follows:

- | | |
|-----------|---|
| 1.0 – 1.2 | Smooth operation at low speed at constant load without shocks |
| 1.2 – 1.5 | Smooth operation with load variation |
| 1.5 – 2.0 | Operation with small shocks and vibrations |
| 2.0 – 4.0 | High acceleration, shocks and vibrations |

Once P_a and P_r have been defined we can proceed to calculate the equivalent load P_{eq} (not for FRN ... EI).

$$P_{eq} = X \cdot P_r + Y \cdot P_a \quad (N)$$

In this case the external load F_1 , applied at the point of coordinate $y_1 z_1$, should be considered together with reaction $(F_2 = -F_1)$ applied at the point of co-ordinate $y_2 z_2$.

Calling Δ_y the absolute value of $y_2 - y_1$ and Δ_z the absolute value of $z_2 - z_1$, the following formula is used:

Coefficients X and Y can be obtained from guide roller tables (in the case of tapered bearings according to the ratio between P_a e P_r). In

case of pure radial guide roller as PK and GC or floating bearings FRL, RAL, RKXL, RKUL.

$$P_{eq} = P_r \quad (N)$$

Nominal bearing life:

$$L_{10} = 100 \cdot \left(\frac{C_w}{P_{eq} \cdot f_w} \right)^p \quad (km)$$

Where coefficient p is:

- $p = 3$ for ball bearing guide rollers (FR ... EU, RCL ..., PFV ..., RAL)
- $p = 10/3$ for roller bearing guide rollers (PK ..., RKY, RKX, Rolbloc, GC ...)

In case of guide rollers based on needle bearings type FRN ... El nominal bearing life is calculated as the minimum between:

$$L_{10} = 100 \cdot \left(\frac{C_{wr}}{P_r \cdot f_w} \right)^{10/3} \quad (km)$$

and

$$L_{10} = 100 \cdot \left(\frac{C_{wa}}{P_a \cdot f_w} \right)^{10/3} \quad (km)$$

CHECKING THE GUIDE ROLLER MAX. LOAD

The values of the radial limit loads F_r and axial limit loads F_a shown in the catalogue refer to extreme operating conditions, meaning:

- $P_a = 0$ (pure radial load)
- $P_r = P_a \cdot \tan \alpha$ (maximum axial load)

In intermediate cases, when the ratio is included between the extreme values, the equivalent limit load F_k to be considered must be calculated according to ratio $k = P_a/P_r$.

$$F_k = \frac{F_r \cdot F_a}{k \cdot F_r + (1 - k \tan \alpha) \cdot F_a} \quad (N)$$

To check the strength of the guide roller, in relation to the limit load, the safety factor has to be greater than 1.

$$F_k/P_r > 1$$

Note: in the following common cases it is not necessary to calculate F_k and the evaluation can be completed easily. Rollers that allow axial movement (FRL, PK, RKYL, RKUL, GC) don't support axial loads.

In case of loads acting in the guide roller plane (F_x o F_y acting with $Z=0$) the axial load is also zero (0) (see calculation example n° 3).

In these cases it has to be:

$$F_r/P_r > 1$$

In case of load F_z acting perpendicular to guide roller plane the axial load is maximum (see calculation example n°4).

$$F_a/P_a > 1$$

EXAMPLES OF CALCULATION

EXAMPLE N° 1:

A FORK-LIFT TRUCK FEATURING VERTICAL MOVEMENT

The resulting magnitude of the weight passes through point ①, while the vertical force that balances this, for instance the traction of a timing belt, passes through point ②.

Guide rollers type RKY 52 are used with guide rail type FS 62 MT:

overload factor $f_w = 1,0$
center distance $l_x = 300 \text{ mm}$
 $l_y = 144.3 \text{ mm}$

$F = 1800 \text{ N}$
 $z_1 = 100 \text{ mm}$
 $y_1 = -150 \text{ mm}$
 $\Delta_2 = 350 \text{ mm}$
 $z_2 = -250 \text{ mm}$
 $y_2 = 350 \text{ mm}$
 $\Delta_y = 500 \text{ mm}$

Scheme 1:

Load on rollers

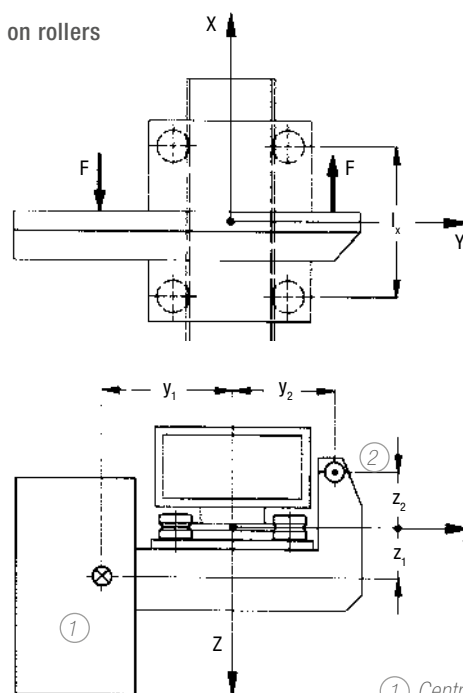

- ① Centre of gravity
- ② Force passing through point

$$P_a = \frac{1800 \cdot 350}{2 \cdot 300} = 1050 \text{ N}$$

$$P_r = \frac{1800}{300} \cdot \left(\frac{350 \cdot \tan 40^\circ}{2} + 500 \right) = 3881 \text{ N}$$

TECHNICAL FEATURES

NADELLA LINEAR SYSTEMS

Nominal life

$$X = 1$$

$$Y = 3.38$$

Equivalent dynamic load

$$P_{eq} = 1 \cdot 3881 + 3.7 \cdot 1050 = 7766 \text{ N}$$

$$L_{10} = 100 \cdot \left(\frac{41000}{7766 \cdot 1} \right)^{10/3} = 25622,5 \text{ km}$$

Limit load check

Equivalent limit load F_k

$$K = P_a/P_r = 0.27$$

$$F_k = \frac{11900 \cdot 4250}{0.27 \cdot 11900 + (1 - 0.27 \cdot \tan 40) \cdot 4800} = 8248 \text{ N}$$

Guide roller safety coefficient

$$F_k/P_r = 8248/3881 = 2,1$$

EXAMPLE N° 2:

THE HORIZONTAL AXIS OF A MANIPULATOR IN STEEL INDUSTRY

The centre of gravity of the vertical axis and load is placed in the middle of the horizontal centre-axis l_x and 160 mm distance from the guide axis. The dirty environment and the possibility of shocks lead to the choice of Rolbloc system.

Scheme 2:

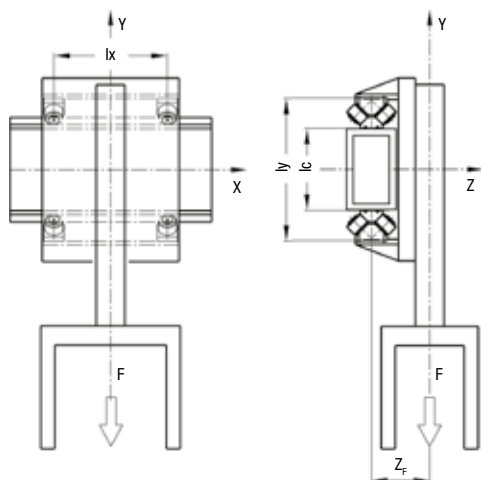

Guide rollers BL 252 are used with guide GU 62 M:

$$\begin{aligned} \text{Overload factor} & f_w = 1.4 \\ \text{Centre distance} & l_x = 350 \text{ mm} \\ & l_y = 400 \text{ mm} \end{aligned}$$

$$\begin{aligned} F &= 6000 \text{ N} \\ x &= 0 \\ y &= -1000 \text{ mm} \\ z_f &= 160 \text{ mm} \end{aligned}$$

Load on rollers

The effective center axis l_c is $400 - 85 - 85 = 230 \text{ mm}$

$$P_a = \frac{6000 \cdot 160}{2 \cdot 230} = 2087 \text{ N}$$

$$P_r = \frac{6000 \cdot (350 + 0)}{2 \cdot 350} + \frac{6000 \cdot 160 \cdot \tan 45}{2 \cdot 230} = 5087 \text{ N}$$

Nominal life

From the Rolbloc table

$$X = 1$$

$$Y = 1$$

$$P_{eq} = 1 \cdot 2087 + 1 \cdot 5087 = 7174 \text{ N}$$

$$L_{10} = 100 \cdot \left(\frac{59000}{7174 \cdot 1.4} \right)^{10/3} = 36577 \text{ km}$$

Limit load check

$$K = P_a/P_r = 2087/5087 = 0.41$$

$$F_k = \frac{16800 \cdot 8400}{0.41 \cdot 16800 + (1 - 0.41 \cdot \tan 45) \cdot 8400} = 11915 \text{ N}$$

$$F_k/P_r = 11915/5087 = 2.3$$

EXAMPLE N° 3:

THE SLIDING DOOR OF A MACHINE TOOL (RAIL ON TOP)

The door is supported by the rail DC type on the upper edge and driven on bottom side by an auto-aligning carriage C3 RAL on LM guide rail type. Because of the effect of the bottom rail there isn't any torque applied at the DC rail. The door weight acts in a plane coincident with the roller / rail vertical axis and as such there is no overturning moment. In this case, limit load calculation can be easily carried out from basic data F_r without F_k calculation. Of course the calculation is always the same.

Scheme 3:

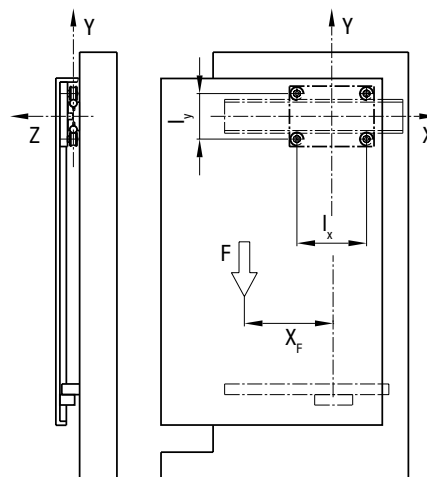

Guide rail DC 18.65 is used with carriage T4 PFV 3518 250:

Overload factor $f_w = 1.1$
 Centre distance $l_x = 213 \text{ mm}$
 $l_y = 113 \text{ mm}$

$F = 450 \text{ N}$
 $x = -300 \text{ mm}$
 $y = -500 \text{ mm}$
 $z = 0 \text{ mm}$ (because of LM rail)

Load on rollers

The effective center axis l_c is $450 + 32 = 482 \text{ mm}$

$$P_a = \frac{450 \cdot 0}{2 \cdot 78} = 0 \text{ N}$$

$$P_r = \frac{450 \cdot (213 + 2 \cdot 300)}{2 \cdot 213} + \frac{450 \cdot 0 \cdot \tan 40}{2 \cdot 213} = 859 \text{ N}$$

Nominal life

$$L_{10} = 100 \cdot \left(\frac{4550}{859 \cdot 1.1} \right)^3 = 11150 \text{ km}$$

Limit load check

$$F_r / P_r = 1500 / 859 = 1.7$$

EXAMPLE N° 4: TRANSFER UNIT

The box weight loads the carriage with max. axial load. In this load configuration the limit load check calculation can be easily done directly by the F_a value without F_k calculation.

Scheme 4:

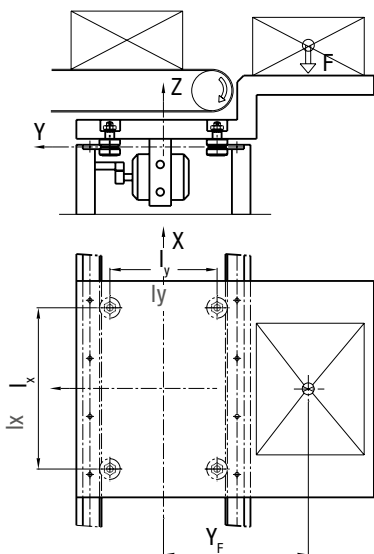

Guide rollers FRN(R) 32 EI with rails FSH 32 M

Overload factor $f_w = 1.2$
 Centre distance $l_x = 670 \text{ mm}$
 $l_y = 450 \text{ mm}$

$F = 400 \text{ N}$
 $x = 0 \text{ mm}$
 $y = 650 \text{ mm}$
 $z = 50 \text{ mm}$

Load on rollers

The effective center axis l_c is $450 + 32 = 482 \text{ mm}$

$$P_a = \frac{400}{4} + \frac{400 \cdot 650}{2 \cdot 482} = 370 \text{ N}$$

$$P_r = 370 \cdot \tan 40 = 310 \text{ N}$$

Nominal Life

$$L_{10r} = 100 \cdot \left(\frac{5600}{310 \cdot 1.2} \right)^{10/3} = 840000 \text{ km}$$

$$L_{10a} = 100 \cdot \left(\frac{2100}{370 \cdot 1.2} \right)^{10/3} = 177600 \text{ km}$$

$L_{10} = 17760 \text{ km}$

Limit load check

$$F_a / P_a = 950 / 370 = 2.5$$

For further details, contact the NADELLA Technical Service.

TECHNICAL FEATURES GUIDE RAIL ORDER CODE

STEEL RAIL

ORDER CODE

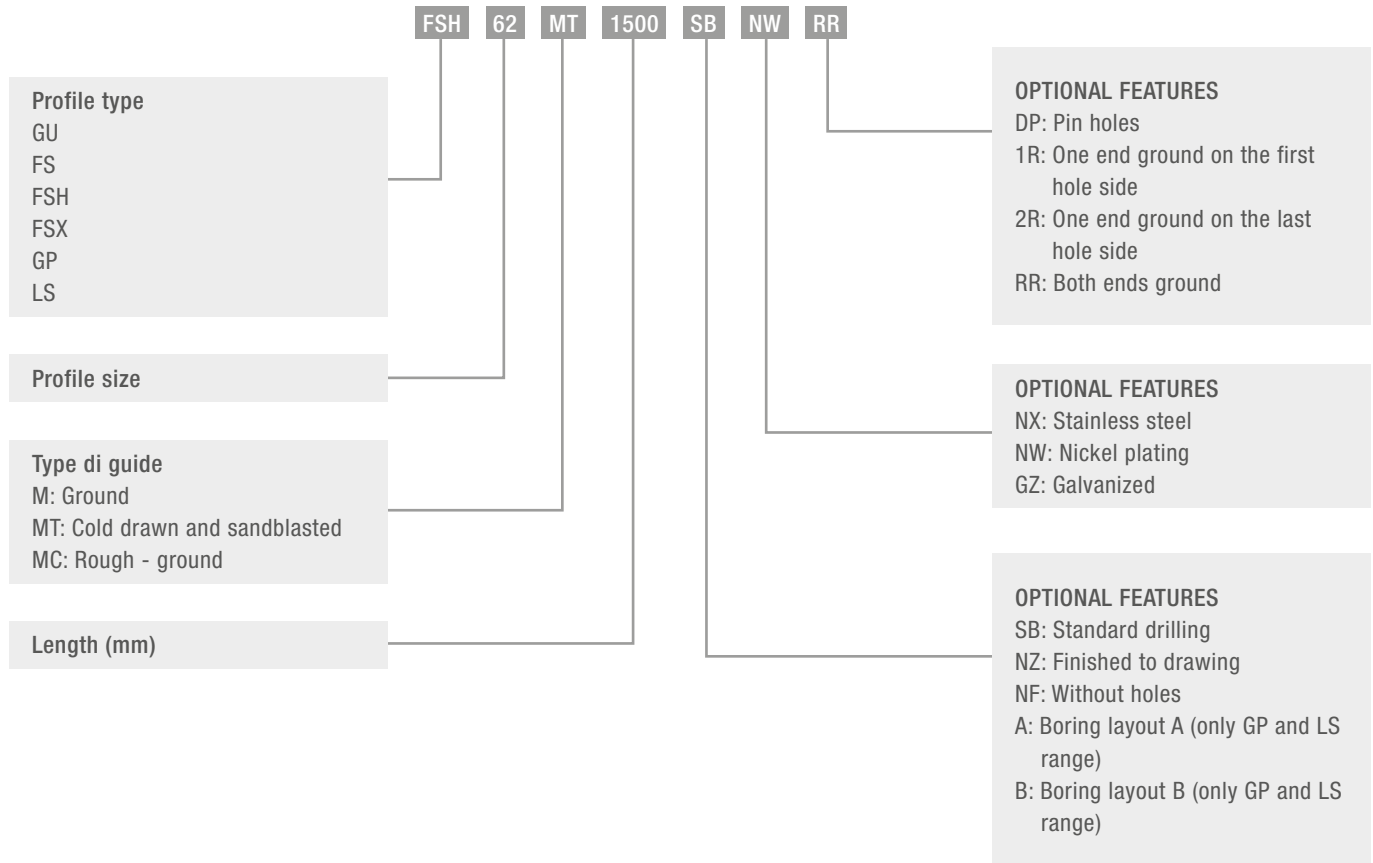

ALLUMINIUM RAIL

ORDER CODE

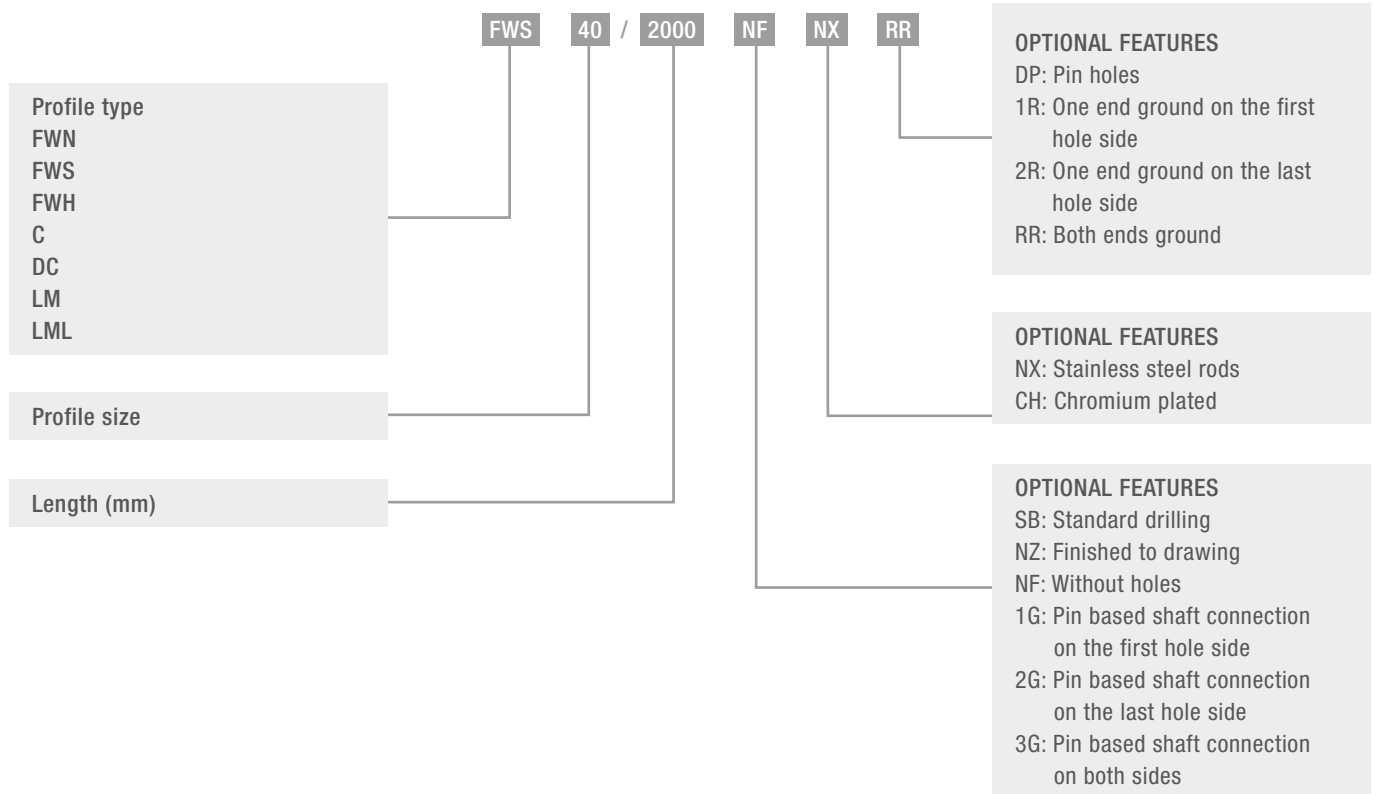

PRODUCT INDEX (IN ALPHABETIC ORDER)

PRODUCT	DESCRIPTION	PAGE
ALS	Alignment device for LS guides on C-Line system	89
BL	Carriage with burnished steel body for the Rolbloc system	40
BL ... DS	Carriage BL with discharge system block	41
C	Rail composed by an aluminium body and one shaft in steel, with a single raceway for Base-Line system	106
C3 RAL C4 RAL	Carriages with body in anodised aluminium with 3 or 4 guide rollers type RAL for auto-aligning system U-Line	138 139
C3 RAN C4 RAN C5 RAN C6 RAN	Carriages with body in steel with 3,4,5 and 6 guide rollers for LS guide of the auto-aligning C-Line	98 99 100 101
C3 RAS C4 RAS C5 RAS	Carriage with body in anodised aluminium with 3, 4 or 5 guide rollers type RAS for auto-aligning system C-Line	95 96 97
C3 RCL C4 RCL	Carriage with body in anodised aluminium with 3 or 4 guide rollers type RCL for U-Line system	138 139
C3 RCL16 NX C4 RCL16 NX	Carriages with 3, 4 anti-corrosion rollers covered in plastic for guides LML 20 for C-Line system	143
C3 RCN C4 RCN C5 RCN C6 RCN	Carriages with steel body with 3, 4, 5 or 6 RCN guide rollers for LS guides of auto-aligning C-Line	98 99 100 101
C3 RCS C4 RCS C5 RCS	Carriages with body in anodised aluminium with 3, 4 or 5 guide rollers type RCS for auto-aligning system C-Line	95 96 97
C3 RYL C4 RYL	Carriage with body in anodised aluminium with 3 or 4 guide rollers type RCL and RAL for auto-aligning system U-Line	138 139
C3 RYN C4 RYN C5 RYN C6 RYN	Carriages with “rotating” steel body and with 3, 4, 5, 6 RCN and RAN guide rollers for C-Line system	98 99 100 101
DC	Rail composed by an aluminium body and two shafts in steel, with two raceways for Base-Line system	105
DIST FS	Spacers for rails FS, FSH and FSR	61
FG FGU	Guide rollers with needle roller bearings (FGU), for GP guides	30
FK	Guide roller with tapered roller bearings for GP rails of Heavy-Line system	27
FKU	Guide roller with tapered roller bearings for GU rails of Heavy-Line system	20
FKX	Guide roller with tapered roller bearings for FSX rails of V-Line system	58
FKY	Guide roller with tapered roller bearings for FS and FSH rails of V-Line system	58
FR ... EU	Guide roller with ball bearings for FS and FSH rails of V-Line system, and FWS and FWH rails of Base-Line system	54 116
FR ... EU AS/AZ	Floating guide rollers with ball bearings for FS and FSH rails of V-Line system, and FWS and FWH rails of Base-Line system	55 117
FRL ... EU	Floating guide rollers with needle roller bearings for FS and FSH rails of V-Line system, and FWS and FWH rails of Base-Line system	59
FRN ... EI	Guide roller with needle roller bearings for FS and FSH rails of V-Line system	56
FS ... M FSH ... M	Rail in steel with ground raceways, for V-Line system	49 67
FS ... MT FSH ... MT	Rail in steel with sandblasted raceways, for V-Line system	48 50
FSHZ-FSXZ	Guide rail with integrated rack transmission	52
FSR ... M	Circular rail in steel, for Multi-Motion-Line system	73

PRODUCT INDEX (IN ALPHABETIC ORDER)

PRODUCT	DESCRIPTION	PAGE
FSRO	Oval circuit composed of linear and circular pieces of rail for Multi-Motion-Line system	75
FSRQ	Ring circuit composed of linear and circular pieces of rail for Multi-Motion-Line system	76
FSX ... M	Rail in steel with ground raceways, for V-Line system	51
FSX ... MT	Rail in steel with sandblasted raceways, for V-Line system	50
FWH	Rail composed by an aluminium body and one shaft in steel, with a single raceway for Base-Line system	115
FWN	Rail composed by an aluminium body and two shafts in steel, with two raceways for Flexi-Line 645 system	125
FWS	Rail composed by an aluminium body and two shafts in steel, with two raceways for Base-Line system	114
GC..SW	Guide roller with needle roller bearings for GP rails of Heavy-Line system	28
GLA	Guide roller with double row of balls with oblique contact, with "gothic arch" profile for U-Line system	137
GP ... M	Rail in steel, ground raceways for Heavy-Line system	25
GP ... MC	Rail in steel, rough ground raceways for Heavy-Line system	24
GU ... M	Rail in steel, ground raceways for Heavy-Line and Rolbloc system	39/18
GU ... MT	Rail in steel, sandblasted raceways for Heavy-Line and Rolbloc system	39/18
LM	Rail composed by an aluminium body and two shafts in steel, with two internal raceways for U-line system	134
LML	Rail totally in aluminium with two internal raceways for U-line system	142
LS	Rails totally in steel with internal hardened raceways for C-Line system	90
LUBC	Lubricator for Base-Line system (guide rollers running on C and DC rails)	113
LUBL	Lubricator for Rolbloc	43
LUBM	Lubricator for U-Line system (carriages running in LM rails)	141
LUBR	Lubricator system for circular rails	79
LUBP	Lubricator for Heavy-Line system (guide rollers running on GP rails)	32
LUBU	Lubricator for Heavy-Line system (guide rollers running on GU rails)	22
LUBX, LUBY	Lubricator for V-Line system (guide rollers running on FS and FSH rails)	63
LUBZ	Lubrication wheel	63
NAID	Wipers for C and DC rails of Base-Line system	112
PFV gothic profile	Guide roller with "gothic arch" profile, based on ball bearings, for C and DC rails of Base-Line system, and LM rails of U-Line system	107 135
PFV	Guide roller based on ball bearings, for C and DC rails of Base-Line system, and LM rails of U-Line system	108
PK	Guide roller with tapered roller bearings for GP rails of Heavy-Line system	26
PR	Adjustment plates for BL carriages of Rolbloc system	42
PZ	Pinion for FSHZ-FSXZ guide rail	62
RAL	Floating guide rollers with "gothic arch" profile, with a double row of balls with oblique contact, for LM rails of U-Line system	136
RAN	Floating guide rollers with balls for LS guide of C-Line system	94
RAS	Floating guide rollers with balls for LS rails of C-Line system	92
RCL	Guide rollers with "gothic arch" profile, with a double row of balls with oblique contact, for LM rails of U-Line system	135
RCN	Guide rollers with balls for LS guide of C-Line system	93
RCP	Guide rollers with "gothic arch" profile, with a double row of balls with oblique contact, for LM rails of U-Line system	135
RCS	Guide rollers with balls profile, for LS rails of C-Line system	91
RKO	Guide rollers with tapered roller bearings, with "gothic arch" profile for C and DC rails of Base-Line system	110
RKU	Guide rollers with tapered roller bearings, for GU rails of Heavy-Line system	19
RKUL	Floating guide rollers with tapered roller bearings for GU rails of heavy line system	21
RKX	Guide rollers with tapered roller bearings, for FSX rails of V-Line system	57
RKY	Guide rollers with tapered roller bearings, for FS and FSH rails of V-Line system	57
RKYL RKXL	Floating guide rollers with tapered roller bearings for FS ... rails of V-Line system	60

PRODUCT	DESCRIPTION	PAGE
RPT	Wipers for Rolbloc BL carriages	43
SAG	Guide pins for the mounting alignment of GU rails of Heavy-Line system	23
TA4 / TB4	Carriages with anodised aluminium body with four guide rollers type GLA for FWN rails of Flexi-Line system	126
T4 FR	Carriages with anodised aluminium body with four guide rollers type FR ... EI for FWS rails Base-Line system	119
T4 PFV	Carriages with anodised aluminium body with four guide rollers type PFV with "gothic arch" profile for C and DC rails of Base-Line system, and LM rails of U-Line system	111 140
T4 R ...	Carriages with fixed guide rollers Steering carriage for FSR ... M circular rails of Multi-Motion-Line system	77 78
T4 RAL	Carriages with black anodised aluminium body with four floating guide rollers type RAL with "gothic arch" profile for LM rails of U-Line system	140
T4 RCL T4 RCP	Carriages with black anodised aluminium body with four guide rollers type RCL or RCP with "gothic arch" profile for LM rails of U-Line system	140
T4 RYL	Carriages with black anodised aluminium body with four guide rollers type RCL / RCP and RAL with "gothic arch" profile for LM rails of U-Line system	140

SUFFIX INDEX (IN ALPHABETIC ORDER)

A	Standard hole pattern according to the catalogue for GP rails
AC	Hollow shafts optional for rails C, DC and LM
B	Standard hole pattern according to the catalogue for GP rails
CH	Chromium plated shafts
D	Felt without lubricant
DP	Pin holes
EE	Synthetic sealer for GC
EEM	Ground profile
G	Pin based shaft connection
GZ	Surface zinc-plated for LS rails (C-Line)
M	Ground profile
MC	Rough ground profile (for GP rails)
MM	Metallic sealer for FGU
MT	Sandblasted profile
NF	Rails without holes
NX	Stainless steel version for guide rollers or guide rails
NW	Chemical nickel-plating
NZ	Finishes to drawing
1R	One end ground on the first hole side
2R	One end ground on the last hole side
RR	Both ends ground
S	Holes for DC guide
SB	Standard hole pattern according to the catalogue
UU	Felts for lubrication available (for carriages TA4 and TB4 of Flexi-Line 645 system)
V	Seals in Viton



NADELLA / nadella.com

DURBAL / durbal.com

CHIAVETTE UNIFICATE / chiavette.com

IPIRANGA / ipirangahusillos.com

SHUTON / shuton.com

THE SPECIALIST FOR MOTION TECHNOLOGY

NL211EN

Version 02/2021 · Nadella Group | nadella.com | Errors and omissions excepted.