

# BK8

## WITH ISO FLANGE CONNECTION

50 - 2,600 Nm



### PROPERTIES

#### FEATURES

- ▶ for ISO flange output gearboxes
- ▶ allows for continuous hollow through axis with some right angle gearbox designs
- ▶ compact design

#### MATERIAL

- ▶ **Bellows:** high grade stainless steel

- ▶ **Hubs:** up through size 300 aluminum, size 1500 and up steel
- ▶ **Adapter flange:** steel

#### DESIGN

One clamping hub on one end with an integral flange and adapter flange on the other end. Maximum transmittable torque depends on the bore diameter.

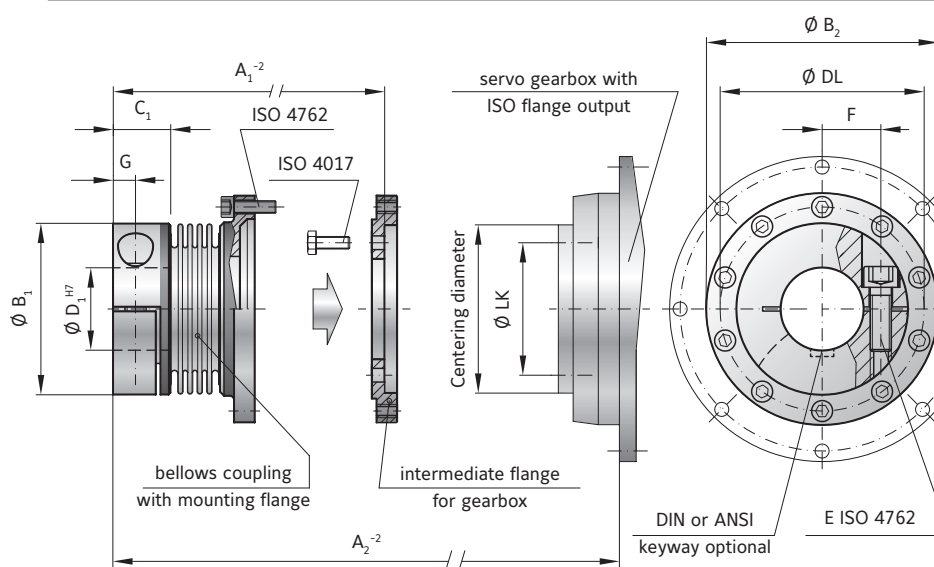

## MODEL BK8

SIZE		15	60	150	300	1500
Flange centering diameter	(mm)	40 h7	63 h7	80 h7	100 h7	160 h7
Flange bolt circle / thread $\emptyset$	(mm)	31.5 / 8 x M5	50 / 8 x M6	63 / 12 x M6	80 / 12 x M8	125 / 12 x M10
Maximum torque*	(Nm)	50	210	380	750	2600
Length -2	(mm) A <sub>1</sub>	48.5	67	72	90	140
Length -2	(mm) A <sub>2</sub>	68	97	101	128	190
Outside diameter of hub	(mm) B <sub>1</sub>	49	66	82	110	157
Flange diameter	(mm) B <sub>2</sub>	63.5	86	108	132	188
Fit length	(mm) C <sub>1</sub>	16.5	23	27.5	34	55
Inside diameter possible from $\emptyset$ to $\emptyset$ H7	(mm) D <sub>1</sub>	12-28	14-35	19-42	24-60	50-80
Hub bolt circle	(mm) DL	56.5	76	97	120	170
Fastening threads	(mm)	10 x M4	10 x M5	10 x M6	12 x M6	16 x M8
Fastening screws ISO 4762		1 x M5	1 x M8	1 x M10	1 x M12	2 x M20
Tightening torque of the fastening screw	(Nm) E <sub>1</sub>	8	45	80	120	470
Distance between centerlines	(mm) F	1 x 17.5	1 x 23	1 x 27	1 x 39	2 x 55
Distance	(mm) G	6.5	9.5	11	13	22.5
Approximate weight	(kg)	0.3	0.7	1	2.8	10
Moment of inertia	(10 <sup>-3</sup> kgm <sup>2</sup> ) J <sub>ges</sub>	0.15	0.65	1.3	5.5	45
Lateral	$\pm$ (mm)	0.25	0.25	0.25	0.25	0.25
Angular	$\pm$ (degree)	1	1	1	1	1
Axial	$\pm$ (mm)	1	1.5	2	2.5	3

\* maximum torque transmittable only for brief periods and requires maximum bore for clamping strength

ORDERING EXAMPLE	BK8	60	22.23	67	XX
Model	●				
Size		●			
Bore D1 H7			●		
Overall length mm				●	
For custom features place an XX at the end of the part number and describe the special requirements (e.g. BK8 / 60 / 22.23 / 67 / XX; XX=anodized hubs)					

Special designation only (e.g. special bore tolerance).