

MK3

WITH EXPANDING SHAFT 0.5 - 10 Nm



PROPERTIES

FEATURES

- ▶ for hollow shaft mounting
- ▶ easy to install
- ▶ light weight and low moment of inertia

▶ **Expanding shaft:** steel

DESIGN

One clamping hub with one clamping screw, one expanding shaft system, both concentrically mounted to flexible bellows.

MATERIAL

- ▶ **Bellows:** high grade stainless steel
- ▶ **Clamping hub:** aluminium

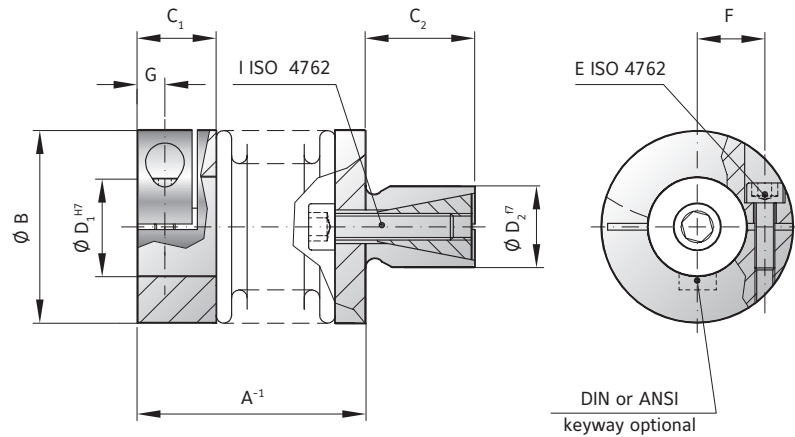

MINIATURE
COUPLINGS MK

MODEL MK3

SIZE		5			10			15			20			45		100	
Rated torque (Nm)	T_{KH}	0.5			1			1.5			2			4.5		10	
Overall length (mm)	A^{-1}	20	23	26	22	25	28	24	30	27	33	36	36	44	41	51	
Outside diameter (mm)	B	15			15			19			25			32		40	
Fit length (mm)	C_1	9			9			11			13			16		16	
Shaft length (mm)	C_2	10			10			12			12			15		20	
Inside diameter possible from \emptyset to \emptyset H7 (mm)	D_1	3-7			3-7			4-8			4-12.7			5-16		6-24	
Standard shaft possible from \emptyset to \emptyset f7 (mm)	D_2	8-10			8-10			10-14			10-16			14-20		16-24	
Fastening screw ISO 4762	E	M2			M2			M2.5			M3			M4		M4	
Tightening torque of the fastening screw (Nm)		0.43			0.43			0.85			2.3			4		4.5	
Distance between centerlines (mm)	F	4.5			4.5			6			8			10		15	
Distance (mm)	G	3			3			3.5			4			5		5	
Fastening screw ISO 4762	I	M3			M3			M4			M4			M5		M6	
Tightening torque of the fastening screw (Nm)		1.5			1.5			3			4			6.5		11	
Moment of inertia (gcm ²)	$J_{res.}$	2.6	2.8	3.0	3.0	3.4	3.6	8.5	9.5	25	27	29	100	108	160	205	
Torsional stiffness (Nm/rad)	C_T	280	210	170	510	380	320	750	700	1200	1300	1200	7000	5000	9050	8800	
Axial (mm)	Max. values	0.4	0.5	0.6	0.4	0.5	0.6	0.5	0.7	0.5	0.6	0.7	0.7	1	1	1.2	
Lateral (mm)		0.15	0.2	0.25	0.15	0.2	0.25	0.15	0.2	0.15	0.2	0.25	0.2	0.25	0.2	0.3	
Angular (degree)		1	1.5	2	1	1.5	2	1.5	1.5	1.5	1.5	2	1.5	2	1.5	2	

ORDERING EXAMPLE	MK3	20	36	6.35	12	XX
Model	●					Special designation only (e.g. special bore / shaft tolerance).
Size		●				
Overall length mm			●			
Bore D1 H7				●		
Shaft D2 f7					●	

For custom features place an XX at the end of the part number and describe the special requirements (e.g. MK3 / 20 / 36 / 6.35 / 12 / XX; XX=finely balanced for 25,000 rpm)