

SCL3

WITH EXTERNAL CLAMPING RING

25 - 100 Nm

PROPERTIES



NEW

FEATURES

- ▶ high torsional stiffness
- ▶ low inertia
- ▶ backlash free
- ▶ low imbalance

DESIGN

Two precision machined coupling hubs and precision spacer mounted to the disc packs by means of high strength screws and spacers for frictional clamping of the assembly.

MATERIAL

- ▶ **Disc packs:** highly elastic spring steel
- ▶ **Hubs and spacer:** aluminium

S = Single flex coupling

D = Double flex coupling

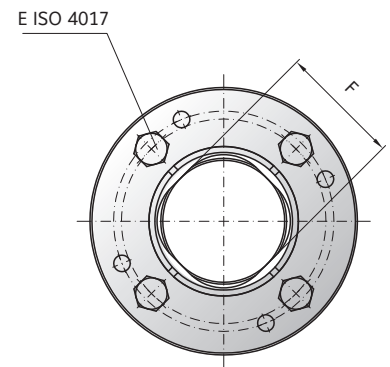
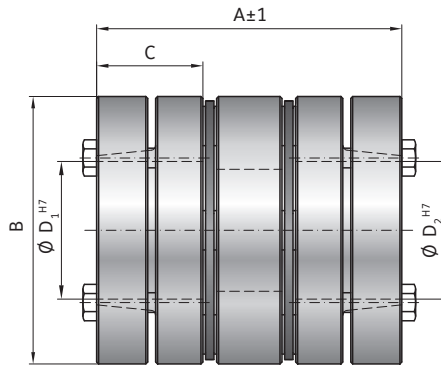
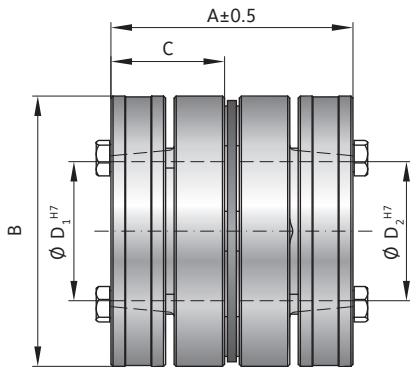

MODEL SCL3

SIZE		25		40		60		100	
System		S	D	S	D	S	D	S	D
Rated torque (Nm)	T_{KN}	25		40		60		100	
Maximum torque (mm)	T_{Kmax}	37.5		60		90		150	
Coupling length (mm)	A	56.6	73.2	56.9	75.3	57.5	77.6	73.7	103.8
Outside diameter (mm)	B	56		63		68		82	
Fit length (mm)	C	27		27		27		32.5	
Bore diameter H7 (mm)	D_1 / D_2	18-28		20-30		27-35		24-40	
Fastening screw	E	M5		M5		M5		M5	
Tightening torque (Nm)		5.5		6		6		6	
Shaft diameter limitation (mm)	F	26		-		31		38	
Moment of inertia (10^{-3} kgm^2)	J_{ges}	0.144	0.187	0.230	0.304	0.310	0.422	0.837	1.170
Weight (kg)		0.299	0.390	0.384	0.508	0.435	0.603	0.835	1.156
Torsional stiffness (Nm/rad)	C_T	46000	23000	58000	29000	82000	41000	157000	78500
Axial displacement ± (mm)		0.4	0.81	0.42	0.85	0.5	1	0.55	1.15
Lateral displacement ± (mm)	max. values	-	0.29	-	0.32	-	0.35	-	0.53
Angula displacement ± (degree)		1	2	1	2	1	2	1	2
Max. speed (1/min)		10000							

ORDERING EXAMPLE	SCL3	60	D	28	33	XX
Model	●					Special designation only (e.g. balanced G2.5)
Size		●				
System			●			
Bore Ø D1 H7				●		
Bore Ø D2 H7					●	

For custom features place an XX at the end of the part number and describe the special requirements (SCL3 / 60 / D / 28 / 33 / XX)

SERVO DISC PACK
COUPLINGS SCL