

PROPERTIES



MATERIAL

- ▶ **Clutch system:** hardened steel
- ▶ **Hub D1:** up to size 450 high strength aluminum, size 800 and up steel
- ▶ **Hub D2:** up to size 60 high strength aluminum, size 150 and up steel
- ▶ **Elastomer insert:** wear resistant thermally stable TPU

DETAILS FOR ELASTOMER INSERTS see page 72/73

DESIGN

Two clamping hubs with one clamping

screw in each and concave driving jaws. Backlash free, vibration damping, electrically isolating elastomer insert press fit into the jaw sets. Clutch system: spring loaded ball-detent principle.

AVAILABLE FUNCTION SYSTEMS

- ▶ **W** = Single position / automatic re-engagement (standard)
- ▶ **D** = Multi-position / automatic re-engagement
- ▶ **G** = Load holding / load blocking
- ▶ **F** = Full disengagement / manual re-engagement

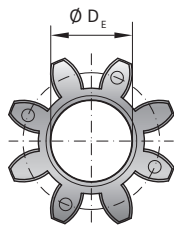

Size 5-800 elastomer insert type A / B

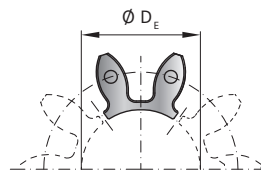

Size 1500 includes 5x elastomer segments type A / B

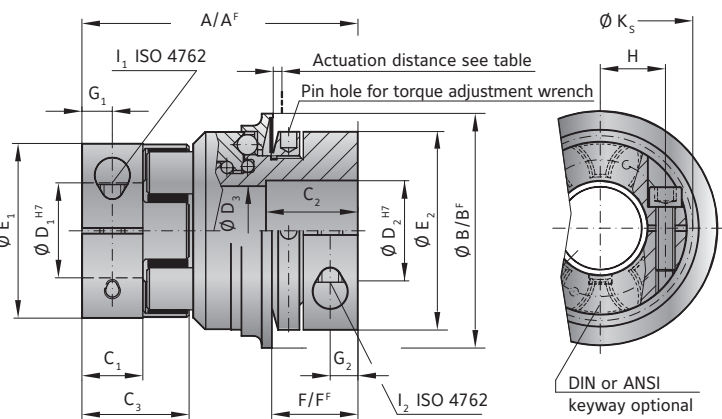

MODEL ES2

Size		5		10		20		60		150		300		450		800		1500	
Type (Elastomer insert)		A	B	A	B	A	B	A	B	A	B	A	B	A	B	A	B	A	B
Rated torque (Nm)	T_{KN}	9	12	12.5	16	17	21	60	75	160	200	325	405	530	660	950	1100	1950	2450
Max. torque* (Nm)	T_{Kmax}	18	24	25	32	34	42	120	150	320	400	650	810	1060	1350	1900	2150	3900	4900
Adjustment range possible from -to (Nm)	T_{KN}	1-3 or 3-6		2-6 or 4-12		10-25 or 20-40		10-30 or 25-80		20-70 or 45-150 or 80-180		100-200 or 150-240 or 200-320		80-200 or 200-350 or 300-500		400-650 or 500-800 or 600-900		600-850 or 700-1200 or 1000-1800	
Adjustment range ("F" Version) possible from -to (Nm)	T_{KN}^F	2.5 - 4.5		2-5 or 5-10		8-20 or 16-30		20-40 or 30-60		20-60 or 40-80 or 80-150		120-180 or 180-300		60-150 or 100-300 or 250-500		200-400 or 450-800		1000-1250 or 1250-1500	
Overall length (mm)	A	50	60	60	86	86	96	106	140	140	164	179	245						
Overall length ("F" Version) (mm)	A_F	50	60	86	96	108	143	168	190	257									
Actuation ring \varnothing (mm)	B	35	45	65	73	92	120	135	152	174									
Outside diameter of actuation ring ("F" Version) (mm)	B_F	42	51.5	70	83	98	132	155	177	187									
Clamping fit length (mm)	C_1	8	10.3	17	20	21	31	35	42	51	45	16							
Fit length (mm)	C_2	14	16	27	31	35	42	51	63	74	120								
Length of hub (mm)	C_3	16.7	20.7	31	36	39	52	57	74	120									
Inside diameter from \varnothing to \varnothing H7 (mm)	D_1	4 - 12.7**		5 - 16**		8 - 25		12 - 32		19 - 36		20 - 45		28 - 60		35 - 80		35 - 90	
Inside diameter from \varnothing to \varnothing H7 (mm)	D_2	6 - 14**		6 - 16**		12 - 30		15 - 32		19 - 42		30 - 60		35 - 60		40 - 75		50 - 80	
Diameter \varnothing (mm)	D_3	14.1	20.1	24.1	32.1	36.1	58.1	60.1	68.1	81.1	102.1	136.5	160						
Inside diameter (Elastomer insert) (mm)	D_E	10.2	14.2	19.2	26.2	29.2	46.2	48.2	60.2	79									
Diameter of the hub (mm)	E_1	25	32	42	56	66.5	82	102	136.5	160									
Diameter of the hub (mm)	E_2	19	40	55	66	81	110	123	132	157									
Distance (mm)	F	15	17	24	28	31	35	45	50	63									
Distance ("F" Version) (mm)	F_F	14	16	22	29	30	35	43	54	61									
Distance (mm)	G_1	4	5	8.5	10	11	15	17.5	23	36									
Distance (mm)	G_2	5	5	7.5	9.5	11	13	17	18	22.5									
Distance between centers (mm)	H_1	8	10.5	15	21	24	29	38	50.5	57									
Screws (ISO 4762)	I_1	M3	M4	M5	M6	M8	M10	M12	M16	4x M16***									
Tightening torque (Nm)		2	4.5	8	15	35	70	120	290	300									
Distance between centers D2 side (mm)	H_2	10	15	19	23	27	39	41	48	57									
Screws (ISO 4762)	I_2	M4	M4	M6	M8	M10	M12	M16	2x M16	2x M20									
Tightening torque (Nm)		4	4.5	15	40	70	130	200	250	470									
Diameter with screwhead (mm)	K_S	25	32	44.5	57	68	85	105	139	155									
Approx. weight (kg)		0.2	0.3	0.6	1.0	2.4	5.8	9.3	14.3	26									
Moment of inertia (10^{-3} kgm^2)	J_{ges}	0.02	0.06	0.25	0.7	2.3	11	22	33.5	185									
Actuation distance (mm)		0.8	1.2	1.5	1.7	1.9	2.2	2.2	2.2	3.0									

For information on shaft misalignment, torsional stiffness, and other details about the elastomer inserts see page 111. A^F, B^F, L^F = Full disengagement / manual re-engagement version (F)

* Maximum transmittable torque of the clamping hub depends on the bore diameter see table handbook precision couplings on page 78.

** keyway with max. bore only in clamping hub possible.

*** fully split clamping hub with two rows of screws.