



Compliant with  
New Accuracy Standards

# LM Guide

R Guide / Straight-Curved Guide  
Achieving a Simplified Mechanism

# HCR/HMG



**THK CO., LTD.**  
TOKYO, JAPAN

CATALOG No.306-5E

# Contents

## ▼ R Guide Model HCR

Product Overview ..... P. 3 to 8

Dimensional Table ..... P. 9 to 10

Options ..... P. 11 to 13

## ▼ Straight-Curved Guide Model HMG

Product Overview ..... P. 16 to 20

Dimensional Table ..... P. 21 to 22

Options ..... P. 25 to 26



## R Guide

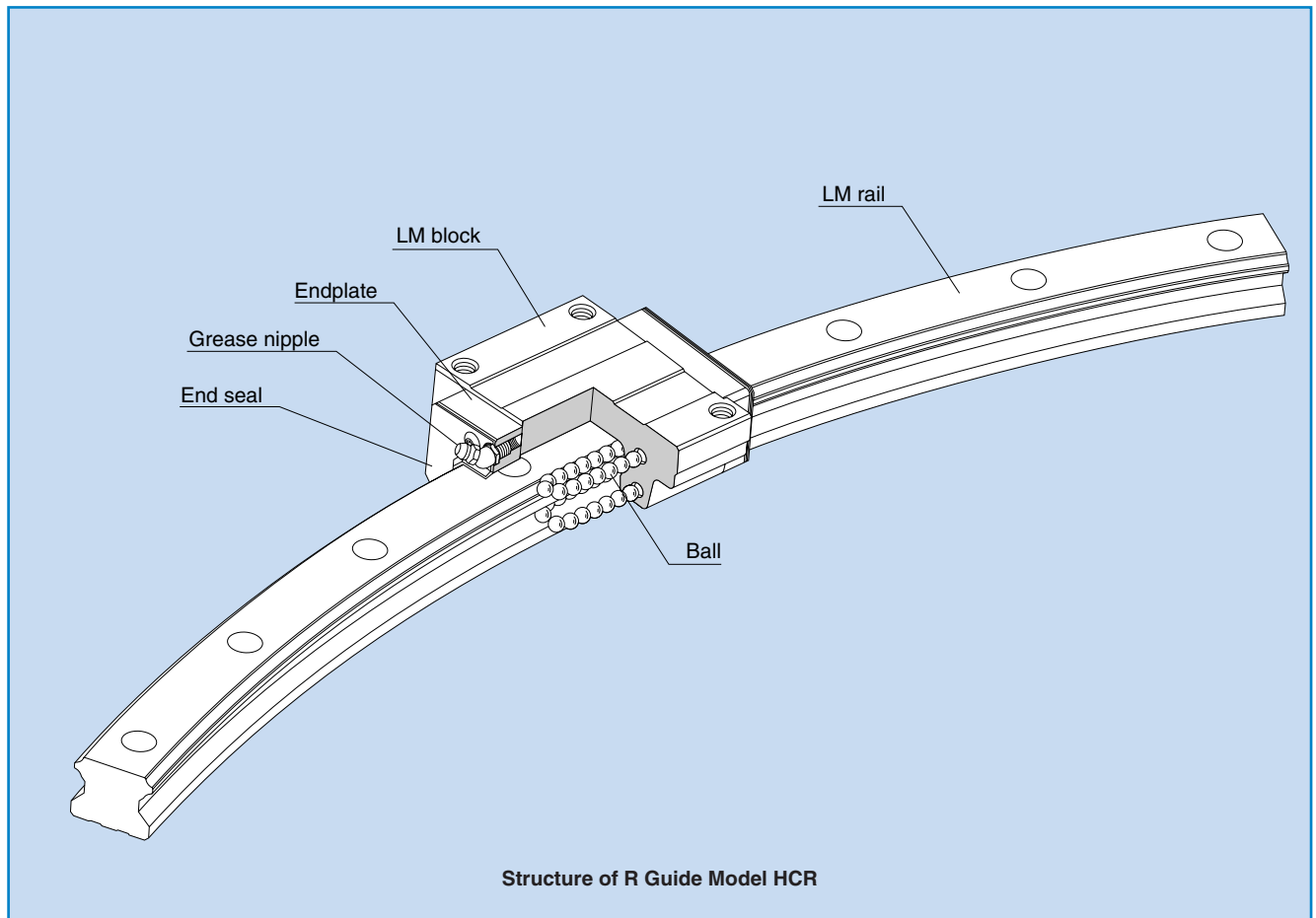

Balls roll in four rows of raceways precision-ground on an LM rail and an LM block, and endplates incorporated in the LM block allow the balls to circulate.

With a structure that is basically the same as four-way equal load type LM Guide model HSR, which has a proven track record, this R Guide is a new concept product that allows highly accurate circular-arc motion.

### ● Freedom of design

Multiple LM blocks can individually move on the same rail. By arranging LM blocks at the load points, efficient structural design is achieved.

### ● Shortened assembly time

This model allows clearance-free, highly accurate circular motion as opposed to sliding guides or cam followers. You can easily assemble this model simply by mounting the LM rail and LM blocks with bolts.

### ● Allows circular motion of 5 m or greater

It allows circular motion of 5 m or greater, which is impossible with swivel bearings.

In addition, the use of this model makes it easy to assemble, disassemble and reassemble equipment that circularly moves.

### ● Capable of receiving loads in all directions

This model is capable of receiving loads in all directions since it has a structure that is basically the same as model HSR.

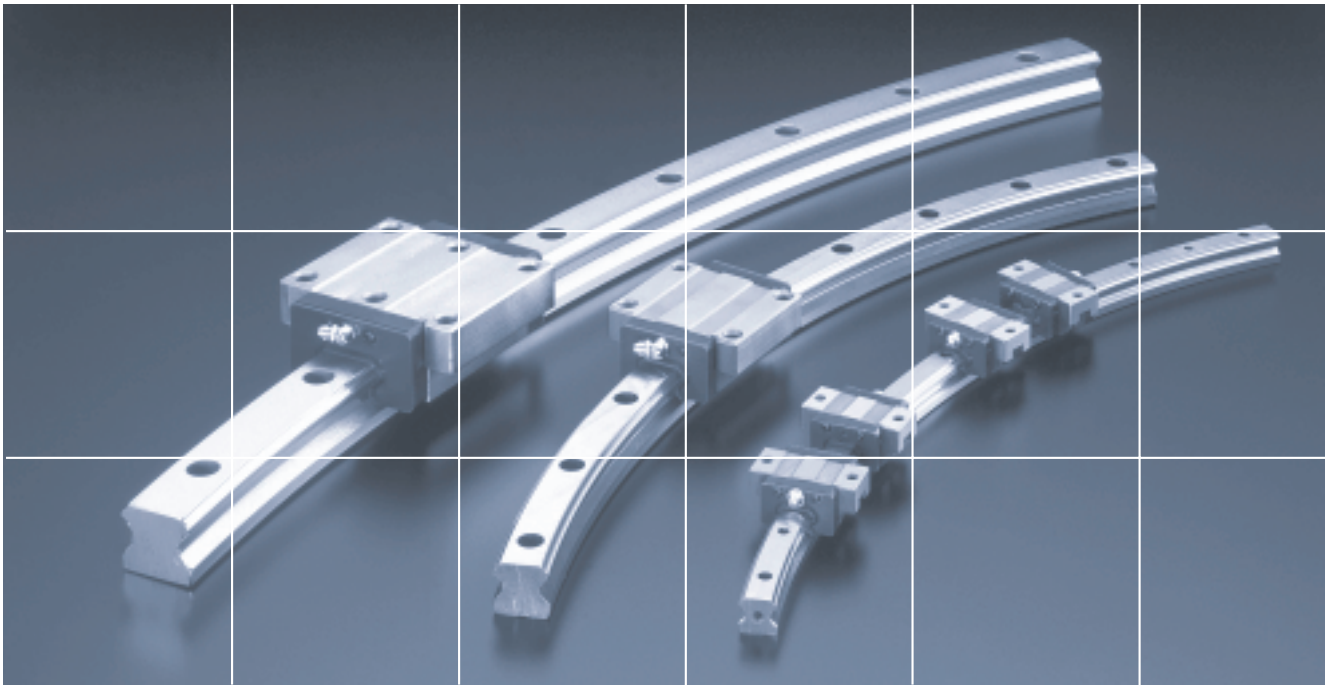

# HCR Outline

## Model HCR - Product Overview

A circular motion guide of 4-way equal-load type, this model ensures backlash-free, highly accurate circular motion. Since it allows efficient design where LM blocks are arranged at the load points, large circular motion can easily be achieved.

**Major applications** Large swivel base / pendulum vehicle for railroad / pantagraph / control unit / optical measuring machine / tool grinding machine / X-ray machine / CT scanner / medical equipment / stage setting / multistory garage / amusement machine / turntable / tool changer

### Model HCR

The flange of its LM block has tapped holes.

- HCR 12A    ● HCR 35A
- HCR 15A    ● HCR 45A
- HCR 25A    ● HCR 65A

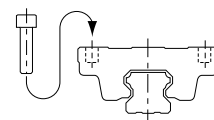
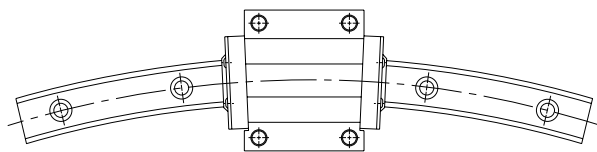

### Rated Loads in All Directions

\*1: Dimensional table for model HCR

Model HCR → pages 9-10

Model HCR is capable of receiving loads in all four directions: radial, reverse-radial and lateral directions.

The basic load ratings are uniform in the four directions (radial, reverse-radial and lateral directions), and their actual values are provided in the dimensional table\*1 for HCR.

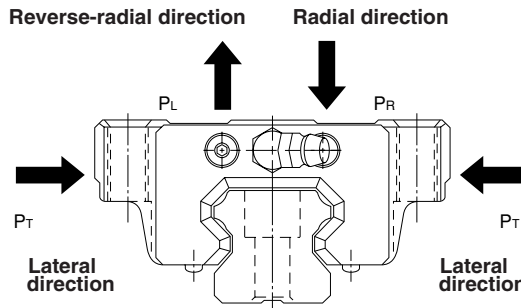

### Equivalent Load

When the LM block of model HCR receives loads in all directions simultaneously, the equivalent load is obtained from the equation below.

$$P_E = P_R (P_L) + P_T$$

where

$P_E$ : Equivalent load	[N]	$P_R$ : Radial load	[N]
· Radial direction		$P_L$ : Reverse-radial load	[N]
· Reverse-radial direction		$P_T$ : Lateral load	[N]
· Lateral direction			

**\*1: Basic dynamic load rating (C)**

It refers to a load with a constant magnitude and direction under which the rated life (L) of a group of identical LM Guide units independently operating is 50 km.

# Service life

The service life of an LM Guide is subject to variations even under the same operational conditions. Therefore, it is necessary to use the rated life defined below as a reference value for obtaining the service life of the LM Guide.

## Rated life

The rated life means the total travel distance that 90% of a group of units of the same LM Guide model can achieve without flaking (scale-like exfoliation on the metal surface) after individually running under the same conditions.

$$L = \left( \frac{f_H \cdot f_T \cdot f_C}{f_W} \cdot \frac{C}{P_C} \right)^3 \times 50$$

- L : Rated life [km]
- C : Basic dynamic load rating\*\* [N]
- P<sub>C</sub> : Calculated load [N]
- f<sub>H</sub> : Hardness factor (see Fig. 1)
- f<sub>T</sub> : Temperature factor (see Fig. 2)
- f<sub>C</sub> : Contact factor (see Table 1)
- f<sub>W</sub> : Load factor (see Table 2)

## Service life time

Once the rated life (L) has been obtained, the service life time can be obtained using the equation on the right if the stroke length and the number of reciprocations are constant.

$$L_h = \frac{L \times 10^6}{2 \times \ell_s \times n_1 \times 60}$$

- L<sub>h</sub> : Service life time [h]
- ℓ<sub>s</sub> : Stroke length [mm]
- n<sub>1</sub> : No. of reciprocations per min [min<sup>-1</sup>]

### f<sub>H</sub> : Hardness factor

To ensure the achievement of the optimum load capacity of the LM Guide, the raceway hardness must be between 58 and 64 HRC. At hardness below this range, the basic dynamic and static load ratings decrease. Therefore, the rating values must be multiplied by the respective hardness factors (f<sub>H</sub>). Since the LM Guide has sufficient hardness, the f<sub>H</sub> value for the LM Guide is normally 1.0 unless otherwise specified.

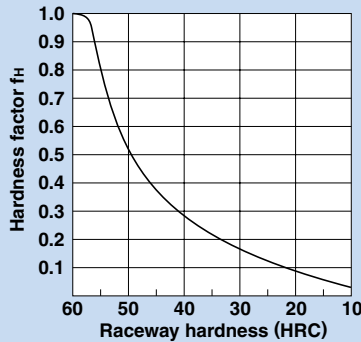

Fig. 1

### f<sub>C</sub> : Contact factor

When multiple LM blocks are used in close contact with each other, it is difficult to achieve uniform load distribution due to moment loads and mounting-surface accuracy. When using multiple blocks in close contact with each other, multiply the basic load rating (C or C<sub>s</sub>) by the corresponding contact factor indicated in Table 1.

Note: When uneven load distribution is expected in a large machine, consider using a contact factor from Table 1.

Table 1 Contact Factor (f<sub>C</sub>)

Number of blocks used in close contact	Contact factor f <sub>C</sub>
2	0.81
3	0.72
4	0.66
5	0.61
6 or more	0.6
Normal use	1

### f<sub>T</sub> : Temperature factor

Since the service temperature of Caged Ball LM Guides is normally 80°C or below, the f<sub>T</sub> value is 1.0.

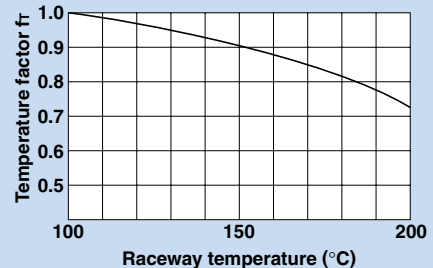

Fig. 2

### f<sub>W</sub> : Load factor

In general, reciprocating machines tend to produce vibrations or impact during operation. It is especially difficult to accurately determine all vibrations generated during high-speed operation and impacts produced each time the machine starts and stops. Therefore, where the effects of speed and vibration are estimated to be significant, divide the basic dynamic load rating (C) by a load factor selected from Table 2, which contains empirically obtained data.

Table 2 Load Factor (f<sub>W</sub>)

Vibration/impact	Speed [V]	f <sub>W</sub>
Faint	Very slow V ≤ 0.25m/s	1 to 1.2
Weak	Slow 0.25 < V ≤ 1m/s	1.2 to 1.5
Moderate	Medium 1 < V ≤ 2m/s	1.5 to 2
Strong	Fast V > 2m/s	2 to 3.5

### Radial Clearance Standard

Since the radial clearance of an LM Guide greatly affects the running accuracy, load carrying capacity and rigidity of the LM Guide, it is important to select an appropriate clearance according to the application.

In general, selecting a negative clearance (i.e., a preload\*1 is applied) while taking into account possible vibrations and impact generated from reciprocating motion favorably affects the service life and the accuracy.

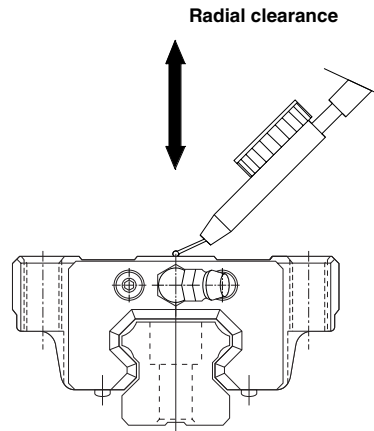

**\*1: Preload**

Preload is an internal load applied to the rolling elements (balls) of an LM block in advance in order to increase its rigidity.

The clearance of all model HCR units is adjusted to the designated value before being shipped. Therefore, it is unnecessary to adjust the preload.

Unit:  $\mu\text{m}$

Model No.	Indication symbol	Normal	Light load
		No symbol	C1
12		- 3 to +3	- 6 to - 2
15		- 4 to +2	- 12 to - 4
25		- 6 to +3	- 16 to - 6
35		- 8 to +4	- 22 to - 8
45		-10 to +5	- 25 to -10
65		-14 to +7	- 32 to -14

**\*1: Running parallelism**

It refers to the parallelism error between the LM block and the LM rail datum plane when the LM block travels the whole length of the LM rail with the LM rail secured on the reference datum plane using bolts.

**\*2: Difference in height M**

It indicates the difference between the minimum and maximum values of height (M) of each of the LM blocks used on the same plane in combination.

**\*3: Difference in width W<sub>s</sub>**

It indicates the difference between the minimum and maximum values of the width (W<sub>s</sub>) between each of the LM blocks, mounted on one LM rail in combination, and the LM rail.

# Accuracy Standard

The accuracy of model HCR is specified in terms of running parallelism (\*1), dimensional tolerance for height and width, and height and width difference between a pair (\*2,\*3) when two or more LM blocks are used on one rail or when two or more rails are mounted on the same plane.

The accuracy of model HCR is categorized into Normal grade and High-accuracy grade by model numbers, as indicated in the table below.

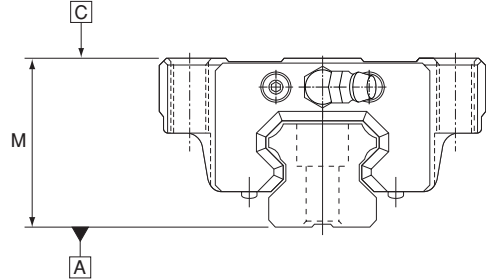

Unit: mm

Model No.	Accuracy standard	Normal grade	High-accuracy grade
	Item	No symbol	H
12 15 25 35	Dimensional tolerance for height M	± 0.2	± 0.2
	Difference in height M	0.05	0.03
	Running parallelism of surface C against surface A	as shown in the table below	
45 65	Dimensional tolerance for height M	± 0.2	± 0.2
	Difference in height M	0.06	0.04
	Running parallelism of surface C against surface A	as shown in the table below	

## LM Rail Length and Running Parallelism for Models HCR

Unit: μm

LM rail length (mm)		Running Parallelism Values	
Above	Or less	Normal grade	High-accuracy grade
		No symbol	H
—	125	30	15
125	200	37	18
200	250	40	20
250	315	44	22
315	400	49	24
400	500	53	26
500	630	58	29
630	800	64	32
800	1000	70	35
1000	1250	77	38
1250	1600	84	42
1600	2000	92	46

## Shoulder Height of the Mounting Base and the Corner Radius

Normally, the mounting base for the LM rail and the LM block has a datum plane on the side face of the shoulder of the base in order to allow easy installation and highly accurate positioning.

The corner of the mounting shoulder must be machined to have a recess, or machined to be smaller than the corner radius "r," to prevent interference with the chamfer of the LM rail or the LM block.

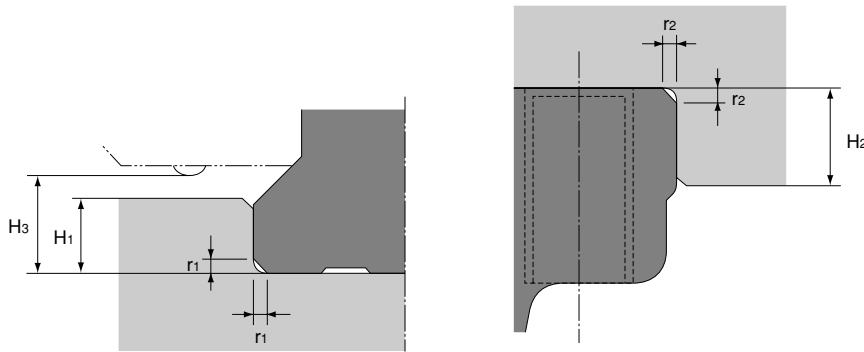

Shoulder for the LM rail

Shoulder for the LM block

Unit: mm

Model No.	Corner radius for the LM rail $r_1$ (max)	Corner radius for the LM block $r_2$ (max)	Shoulder height for the LM rail $H_1$	Maximum shoulder height for the LM block $H_2$	$H_3$
12	0.8	0.5	2.6	6	3.1
15	0.5	0.5	3	4	3.5
25	1	1	5	5	5.5
35	1	1	6	6	7.5
45	1	1	8	8	10
65	1.5	1.5	10	10	14

## Procedure for Assembling Model HCR

To install the LM rails of R Guide model HCR, we recommend having any form of datum point (such as a pin) on the reference side (inside) of the LM rail, and pressing the LM rail to the datum point then stopping the LM rail with a presser plate from the counter-reference surface.

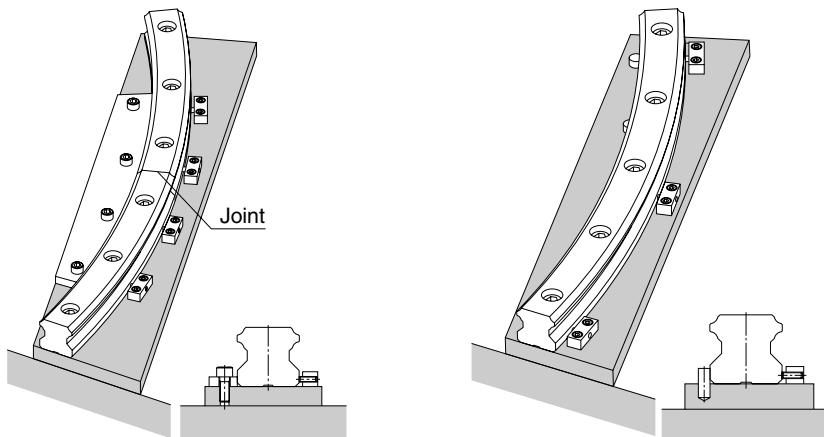

Method for Securing the LM Rails at the Joint

Method for Securing the LM Rail Using a Pin as a Datum Point

# R Guide Model HCR

## Dimensional Table for Model HCR

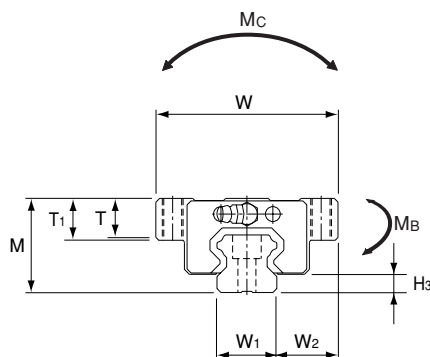

Model No.	Outer dimensions			LM block dimensions									Grease nipple
	Height M	Width W	Length L	B	C	S	L <sub>i</sub>	T	T <sub>i</sub>	N	E		
HCR 12A+60/100R	18	39	44.6	32	18	M 4	30.5	4.5	5	3.4	3.5	PB1021B	
HCR 15A+60/150R	24	47	54.5	38	28	M 5	38.8	10.3	11	4.5	5.5	PB1021B	
HCR 15A+60/300R			55.5										
HCR 15A+60/400R			55.8										
HCR 25A+60/500R	36	70	81.6	57	45	M 8	59.5	14.9	16	6	12	B-M6F	
HCR 25A+60/750R			82.3										
HCR 25A+60/1000R			82.5										
HCR 35A+60/600R	48	100	107.2	82	58	M10	80.4	19.9	21	8	12	B-M6F	
HCR 35A+60/800R			107.5										
HCR 35A+60/1000R			108.2										
HCR 35A+60/1300R			108.5										
HCR 45A+60/800R	60	120	136.7	100	70	M12	98	23.9	25	10	16	B-PT1/8	
HCR 45A+60/1000R			137.3										
HCR 45A+60/1200R			137.3										
HCR 45A+60/1600R			138										
HCR 65A+60/1000R	90	170	193.8	142	106	M16	147	34.9	37	19	16	B-PT1/8	
HCR 65A+60/1500R			195.4										
HCR 65A+45/2000R			195.9										
HCR 65A+45/2500R			196.5										
HCR 65A+30/3000R			196.5										

### ■ Example of model number coding

**HCR25A 2 UU C1+60/1000R H T**

1 2 3 4 5 6 7 8

- 1 Model number
- 2 No. of LM blocks used on the same rail
- 3 Dust prevention accessory symbol (see page 12)
- 4 Radial clearance symbol (see page 6)
- 5 R-Guide center angle
- 6 LM rail radius (in mm)
- 7 Accuracy symbol (see page 7)
- 8 Symbol for connected LM rail type

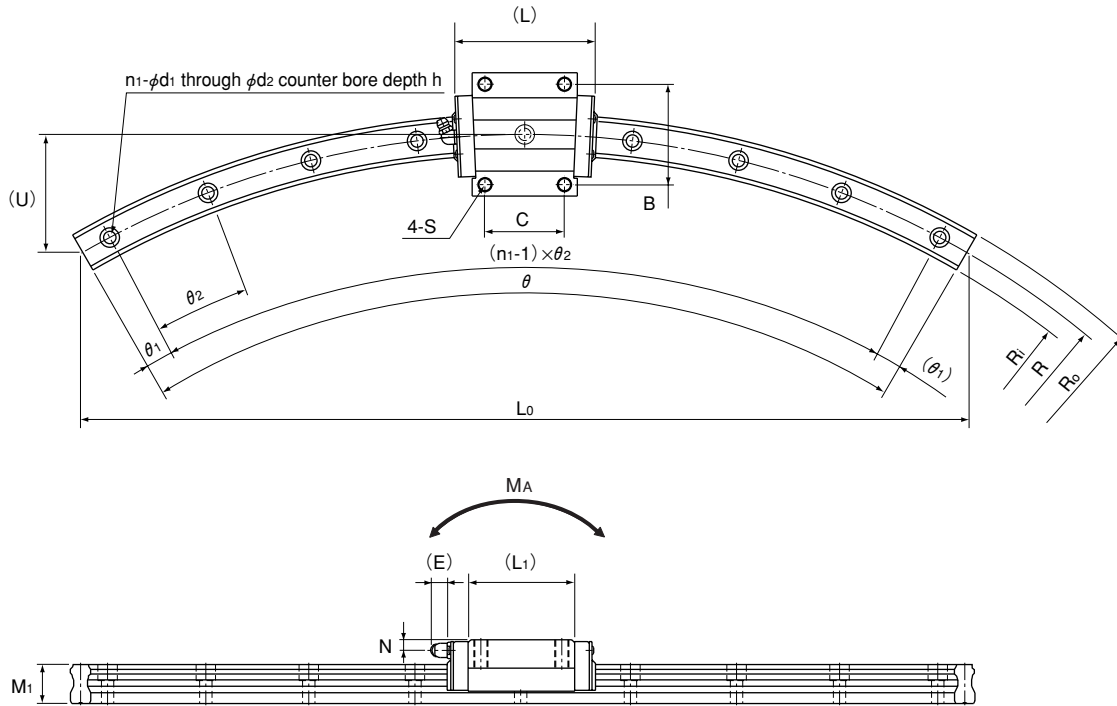

Unit: mm

LM rail dimensions													Basic load rating		Static permissible moment kN-m*					Mass	
R	Ro	Ri	Lo	U	Width	Height	d1 x d2 x h	n1	theta°	theta1°	theta2°	C	Co	MA	MB	MC	LM block	LM rail			
					W1	W2	M1					[kN]	[kN]	1 block	2 blocks in close contact	1 block	2 blocks in close contact	1 block	[kg]	[kg/m]	
100	106	94	100	13.4	12	13.5	11	3.5x6x5	3	60	7	23	4.7	8.53	0.0409	0.228	0.0409	0.228	0.0445	0.08	0.83
150	157.5	142.5	150	20.1					3	7	23	6.66	10.8								
300	307.5	292.5	300	40	15	16	15	4.5x7.5x5.3	5	60	6	12	8.33	13.5	0.0805	0.457	0.0805	0.457	0.0844	0.2	1.5
400	407.5	392.5	400	54					7	3	9	8.33	13.5								
500	511.5	488.5	500	67					9	2	7										
750	761.5	738.5	750	100	23	23.5	22	7x11x9	12	60	2.5	5	19.9	34.4	0.307	1.71	0.307	1.71	0.344	0.59	3.3
1000	1011.5	988.5	1000	134					15	2	4										
600	617	583	600	80					7	3	9										
800	817	783	800	107	34	33	29	9x14x12	11	60	2.5	5.5	37.3	61.1	0.782	3.93	0.782	3.93	0.905	1.6	6.6
1000	1017	983	1000	134					12	2.5	5										
1300	1317	1283	1300	174					17	2	3.5										
800	822.5	777.5	800	107					8	2	8										
1000	1022.5	977.5	1000	134	45	37.5	38	14x20x17	10	60	3	6	60	95.6	1.42	7.92	1.42	7.92	1.83	2.8	11.0
1200	1222.5	1177.5	1200	161					12	2.5	5										
1600	1622.5	1577.5	1600	214					15	2	4										
1000	1031.5	968.5	1000	134					8	60	2	8									
1500	1531.5	1468.5	1500	201					10	60	3	6									
2000	2031.5	1968.5	1531	152	63	53.5	53	18x26x22	12	45	0.5	4	141	215	4.8	23.5	4.8	23.5	5.82	8.5	22.5
2500	2531.5	2468.5	1913	190					13	45	1.5	3.5									
3000	3031.5	2968.5	1553	102					10	30	1.5	3									

**Note**

LM rail radiuses other than the radiuses in the above table are also available. Contact THK for details.

The R-Guide center angles in the table are maximum manufacturing angles. To obtain angles greater than them, rails must additionally be connected. Contact THK for details.

Static permissible moment\*: 1 block: static permissible moment value with 1 LM block

2 blocks: static permissible moment value with 2 blocks closely contacting with each other

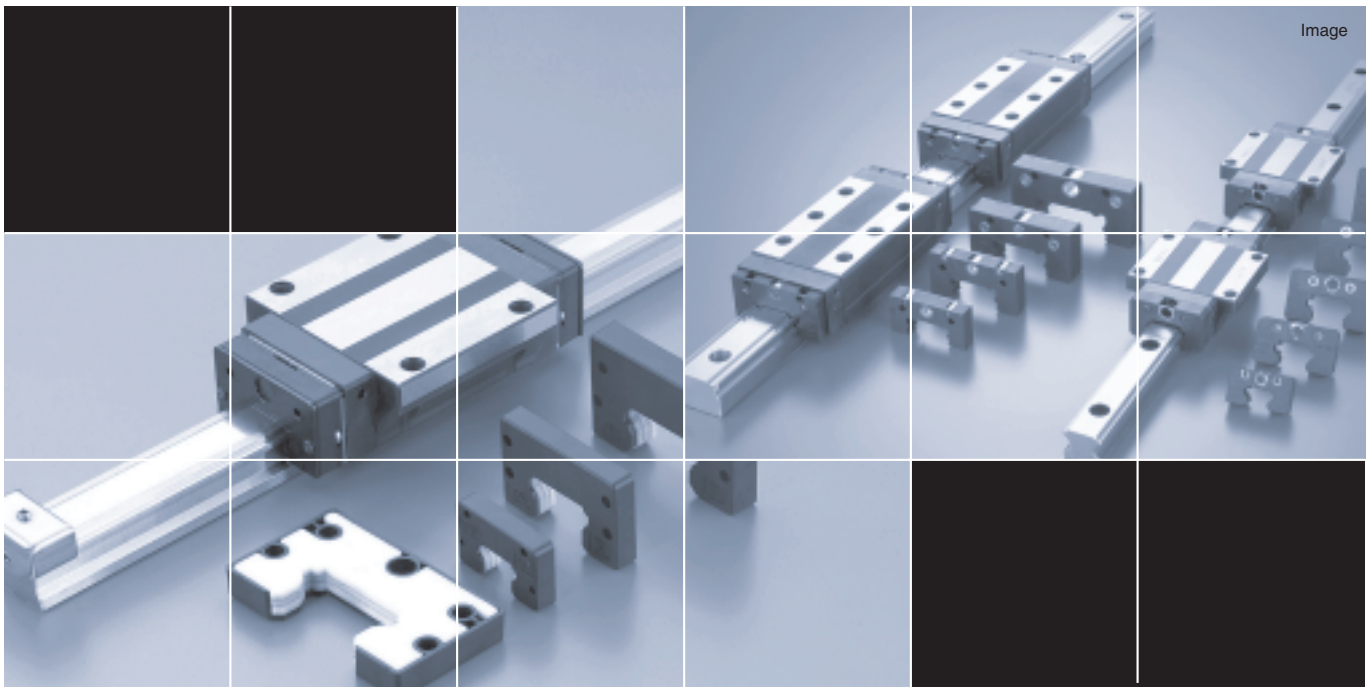

Image

# HCR OPTIONS

## Options

For model HCR, dust-prevention accessories are available. Make a selection according to the application and the installation site.

When foreign matter enters an LM system, it will cause abnormal wear or shorten the service life, and it is necessary to prevent foreign matter from entering the system. Therefore, when possible entrance of foreign matter is predicted, it is important to select an effective sealing device or dust-prevention device that meets the atmospheric conditions.

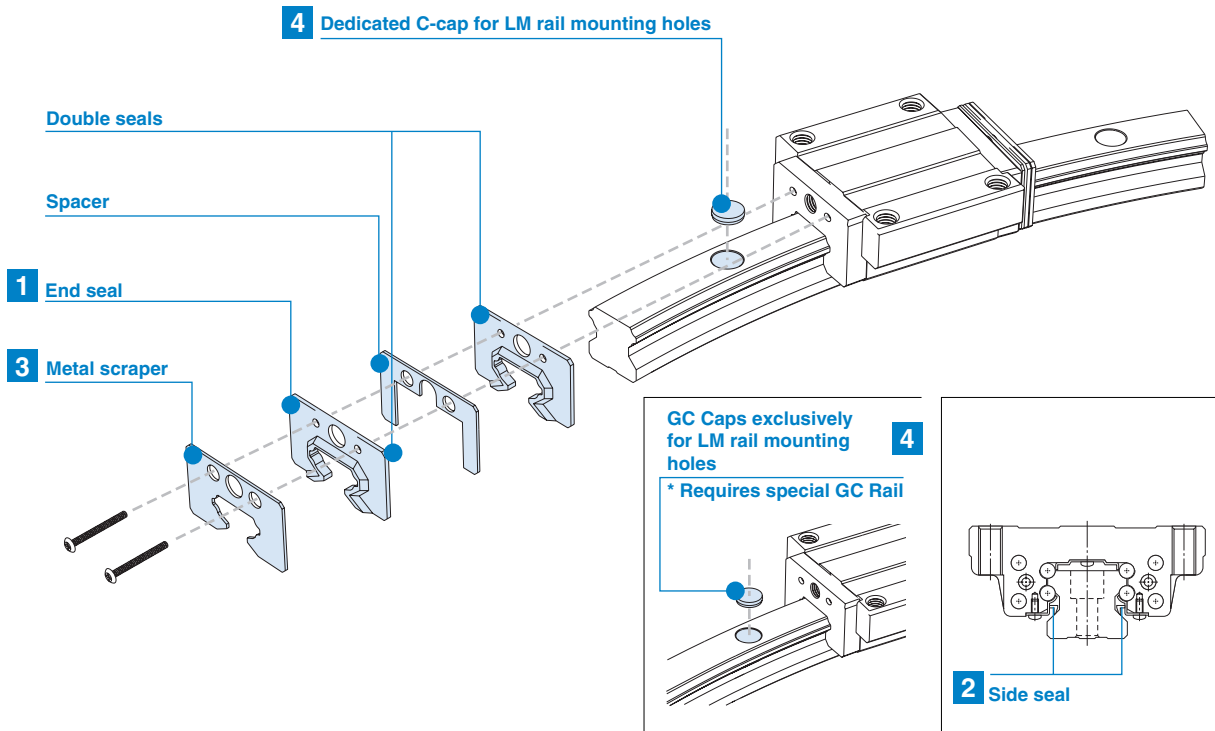

**1 to 3 Seals and a Scraper**

**Highly wear-resistant end seals made of special resin rubber and side seals for increased dust-prevention effect are available.**

If desiring a dust-prevention accessory, specify it with the corresponding symbol indicated in table 2. For the supported model numbers for dust-prevention accessories and the overall LM block length with a dust-prevention accessory attached (dimension L), see table 3.

**Seal resistance value**

For the maximum seal resistance value per LM block when a lubricant is applied on seals HCR···UU, refer to the corresponding value provided in table 1.

Table 1 Maximum Seal Resistance Value of Seals HCR···UU Unit: N

Model No.	Seal resistance value
12	1.2
15	2.0
25	3.9
35	11.8
45	19.6
65	34.3

Table 2 Symbols of Dust Prevention Accessories for Model HCR

Symbol	Dust prevention accessory
UU	With end seal
SS	With end seal + side seal
DD	With double seals + side seal
ZZ	With end seal + side seal + metal scraper
KK	With double seals + side seal + metal scraper
LL	With low-resistance seal
RR	With LL seal + side seal

Table 3 Overall LM Block Length (Dimension L) of Model HCR with a Dust Prevention Accessory Attached Unit: mm

Model No.	UU	SS	DD	ZZ	KK	LL	RR
12A+60/ 100R	44.6	—	—	—	—	—	—
15A+60/ 150R	54.5	54.5	59.7	—	—	54.5	54.5
15A+60/ 300R	55.5	55.5	60.7	57.1	62.3	55.5	55.5
15A+60/ 400R	55.8	55.8	61	57.3	62.5	55.8	55.8
25A+60/ 500R	81.6	81.6	89.2	85.5	93.1	81.6	81.6
25A+60/ 750R	82.3	82.3	89.9	86	93.6	82.3	82.3
25A+60/1000R	82.5	82.5	90.1	86.2	93.8	82.5	82.5
35A+60/ 600R	107.2	107.2	114.8	111.2	118.8	107.2	107.2
35A+60/ 800R	107.5	107.5	115.1	111.5	119.1	107.5	107.5
35A+60/1000R	108.2	108.2	115.8	112	119.6	108.2	108.2
35A+60/1300R	108.5	108.5	116.1	112.3	119.8	108.5	108.5
45A+60/ 800R	136.7	136.7	143.9	142.1	149.2	136.7	136.7
45A+60/1000R	137.3	137.3	144.5	142.7	149.9	137.3	137.3
45A+60/1200R	137.3	137.3	144.5	142.7	149.9	137.3	137.3
45A+60/1600R	138	138	145.2	143.3	150.5	138	138
65A+60/1000R	193.8	193.8	201	199.4	206.6	193.8	193.8
65A+60/1500R	195.4	195.4	202.6	200.8	208	195.4	195.4
65A+60/2000R	195.9	195.9	203.1	201.3	208.5	195.9	195.9
65A+60/2500R	196.5	196.5	203.7	201.8	209	196.5	196.5
65A+60/3000R	196.5	196.5	203.7	201.8	209	196.5	196.5

Note: "—" indicates not available.

Applicability of DD, ZZ and KK depends on the LM rail radius. Contact THK for details.

**End seal**

Used in locations exposed to dust.

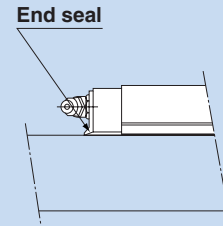

**Side seal**

Used in locations where dust may enter the LM block from the side or bottom surface, such as vertical, horizontal and inverted mounts.

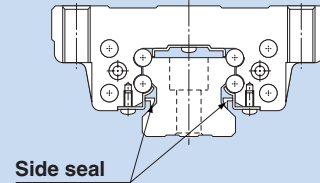

**Metal scraper**

Used in locations where welding spatter may adhere to the LM rail.

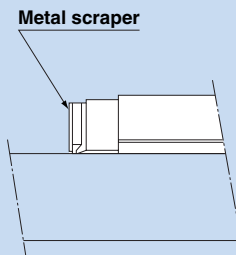

## 4 GC Cap

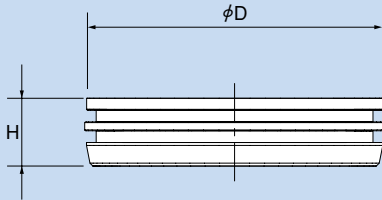

## 4 Metal Cap Dedicated for LM Rail Mounting Holes GC Cap

GC cap is a metallic cap that plugs the LM rail mounting hole (article compliant with the RoHS Directives). It prevents the entrance of foreign material and coolant from the LM rail top face (mounting hole) under harsh environments, and significantly increases the dust control performance of the LM Guide if used with a dust control seal.

Unit: mm

Model No.	Outer diameter D	Thickness H	Model No.	Outer diameter D	Thickness H
GC5	9.86	2.5	GC14	23.36	5.0
GC6	11.36	2.5	GC16	26.36	5.0
GC8	14.36	3.5	GC22	35.36	5.0
GC10	17.86	3.5	GC24	39.36	5.0
GC12	20.36	4.6			

If designating an LM Guide model attached with GC cap, observe the following example of model number coding.

### Example of model number coding

HCR25A 2 UU C1 + 60 / 1000R H T GC

Model number	Dust control option symbol	R-Guide	LM rail length center angle (in mm)	Accuracy symbol	With GC cap Symbol for connected LM rail type
HCR25A	2	UU	C1 + 60	H	T GC
Number of LM blocks per rail		Radial clearance symbol			

Note 1: The LM rail of an LM Guide model attached with GC cap is of special type.

Note 2: GC cap cannot be mounted on an LM rail made of stainless steel or provided with surface treatment.

Note 3: If using the product in a special environment such as vacuum, low temperature or high temperature, contact THK.

Note 4: GC cap is not sold alone. It is always provided in combination with LM Guide.

Note 5: The mouth of the LM rail mounting hole is not chamfered. Take care not to hurt your hand when attaching GC cap.

Note 6: After attaching GC cap, be sure to level and clean (wipe off) the top face of the LM rail.

## 5 Dedicated C-cap

It prevents cutting chips from entering the LM rail mounting holes.

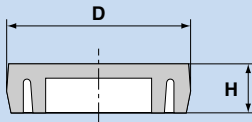

## 5 Dedicated C-cap for LM Rail Mounting Holes

If any of the LM rail mounting holes of an LM Guide is filled with cutting chips or foreign matter, they may enter the LM block structure. Entrance of such foreign matter can be prevented by covering each LM rail mounting hole with the dedicated cap so that the top of the mounting holes is on the same level as the LM rail top face.

The dedicated C-cap for LM rail mounting holes uses a special synthetic resin with high oil resistance and high wear resistance, it is highly durable. When placing an order, specify the desired cap type with the corresponding cap number indicated in the table on the right.

Model No.	C-cap model No.	Bolt used	Major dimensions mm	
			D	H
12	C 3	M 3	6.3	1.2
15	C 4	M 4	7.8	1.0
25	C 6	M 6	11.4	2.7
35	C 8	M 8	14.4	3.7
45	C12	M12	20.5	4.7
65	C16	M16	26.5	5.7

## Straight-Curved Guide

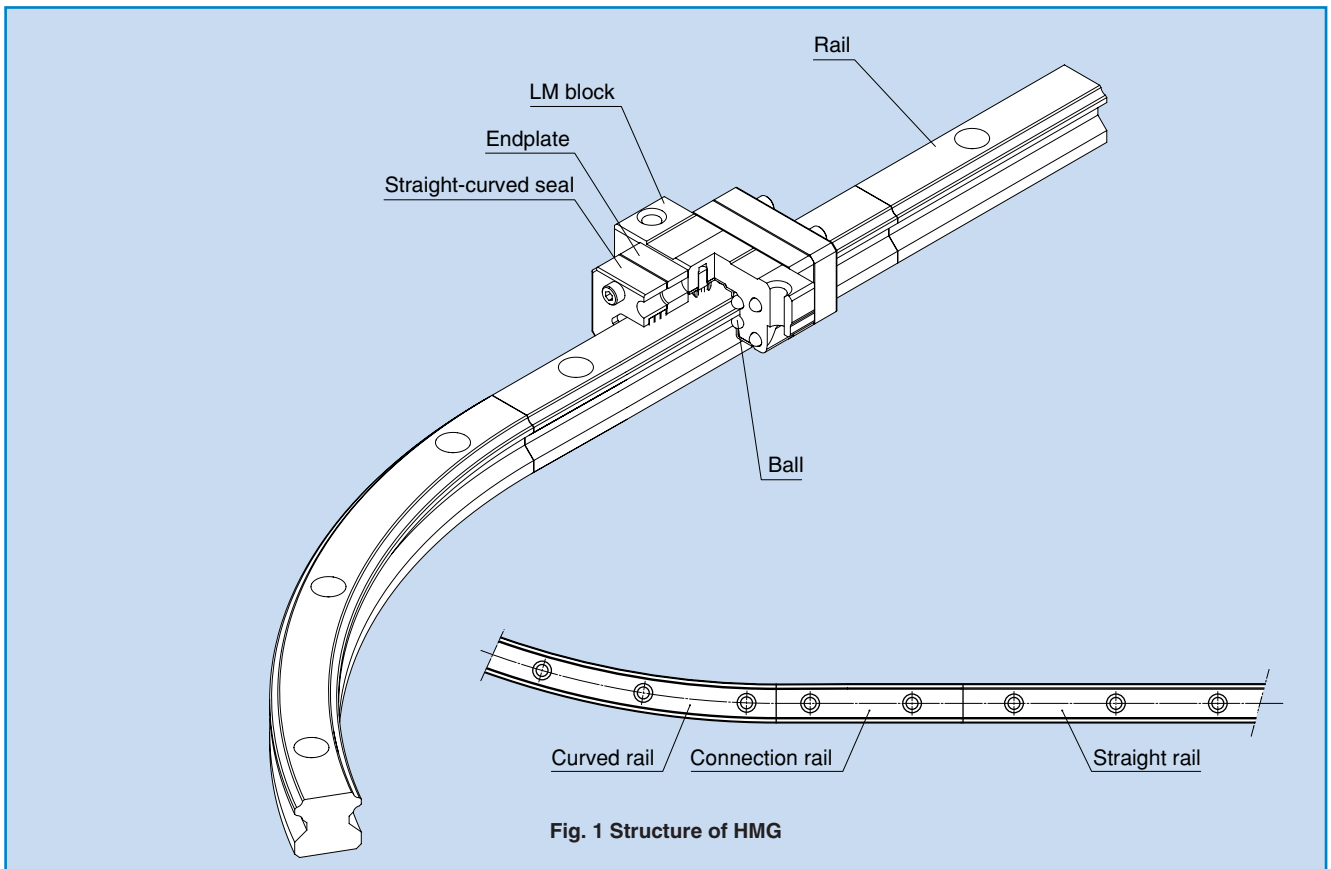

The Straight-Curved Guide HMG is a new straight-curved guide that allows the same type of LM blocks to continuously move on straight and curved rails by combining the technologies of the LM Guide HSR and the R Guide HCR. It achieves drastic cost reduction through improvement of work efficiency at the assembly and conveyance lines and the inspection equipment and simplification of the structure by eliminating a lift and a table.

### ● Free design

It allows free combinations of straight and curved shapes.

Since LM blocks can smoothly transit between the straight and curved sections, various combinations of straight and curved rails can be joined into various shapes such as O, U, L and S shapes. In addition, HMG allows a large table to be mounted and a heavy object to be carried through combinations of multiple blocks on a single shaft or 2 or more LM rails. Thus, it provides great freedom of design.

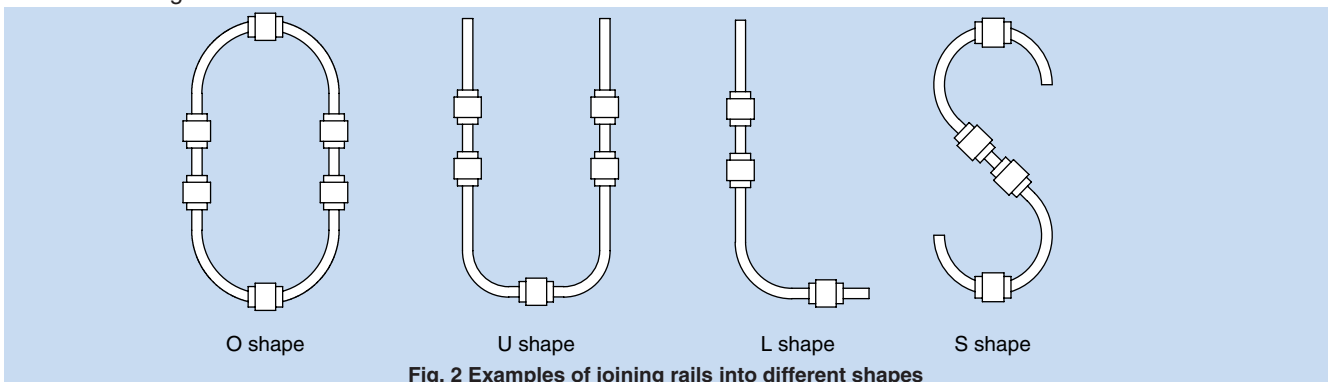

## ● Shortened transportation time

Unlike the shuttle method, using HMG units in a circulating system allows workpieces to be placed while other workpieces are being inspected or mounted, thus significantly improving cycle time. Increasing the number of tables can further shorten cycle time.

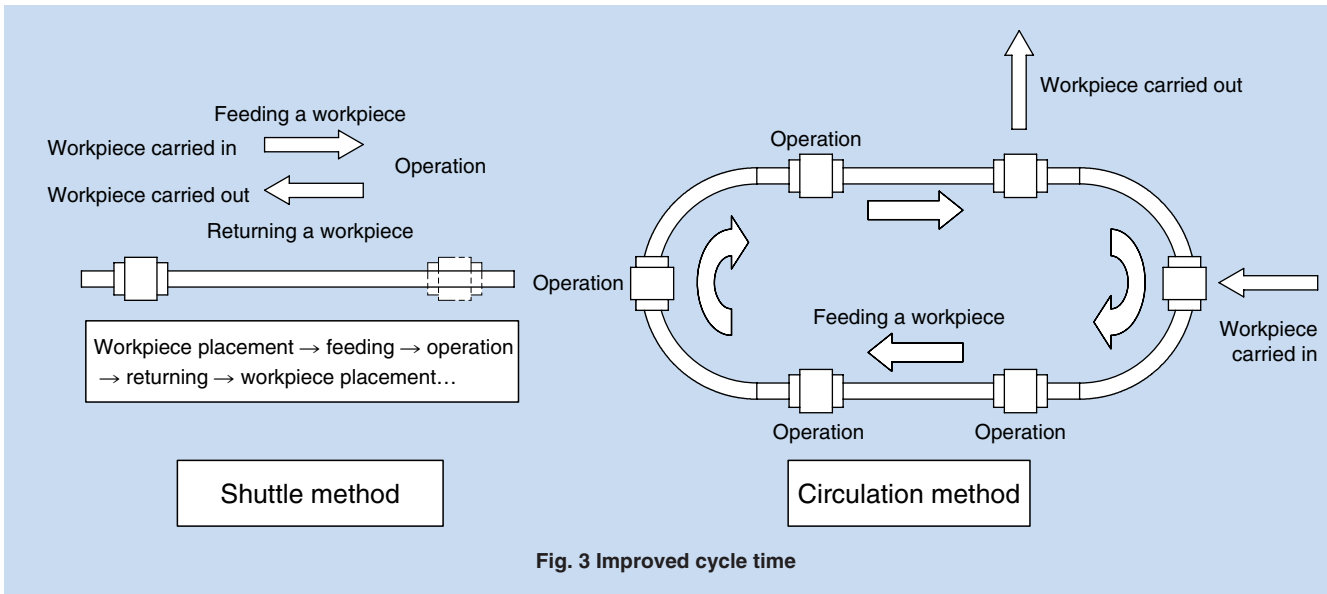

## ● Cost reduction through a simplified mechanism

Combination of straight and curved rails eliminates a lift and a turntable conventionally used for changing directions in the conveyance and production lines. Therefore, use of HMG simplifies the mechanism and eliminates a large number of parts, allowing the cost to be reduced. Additionally, man-hours in designing can also be reduced.

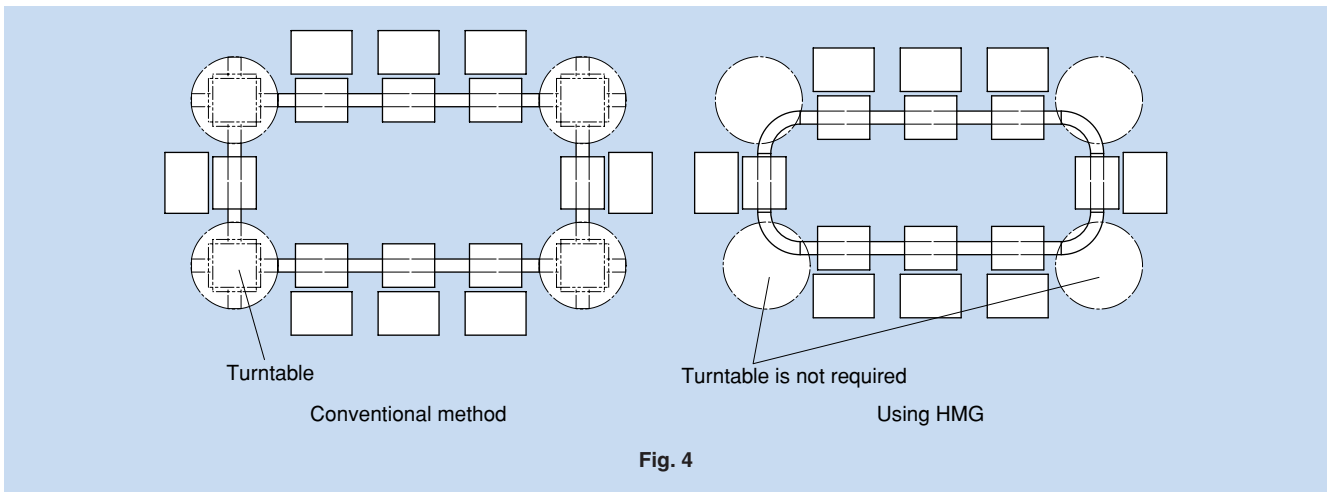

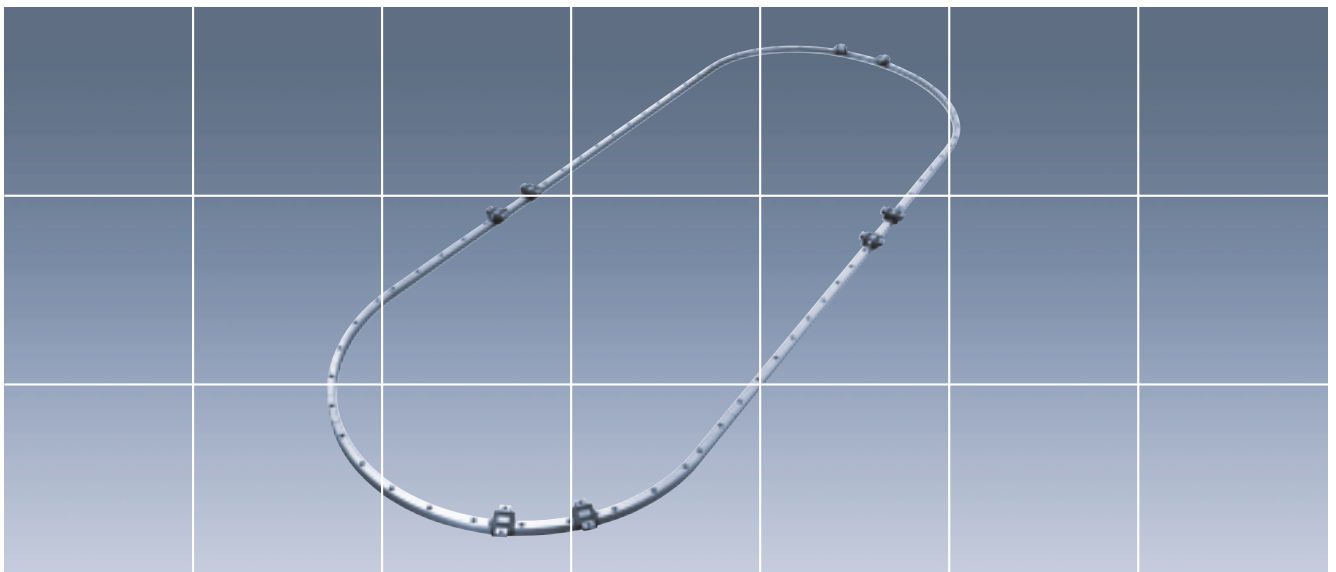

# HMG Outline

## Model HMG - Product Overview

Having a special structure that enables LM blocks to continuously move on straight and curved rails, this model allows free combinations of straight and curved shapes.

**Major applications** Assembly line / conveyance line / inspection machine / large swivel base / amusement machine

### Model HMG

The flange of the LM block has tapped holes. This model can be mounted from the top and the bottom.

- HMG 15
- HMG 25
- HMG 35
- HMG 45
- HMG 65

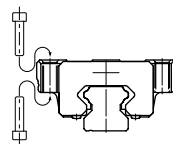
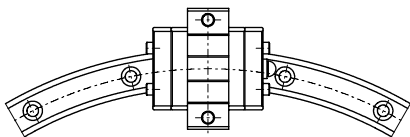

## Rated Loads in All Directions

\*1: Dimensional table for model HMG

Model HMG → pages 21-22

Model HMG is capable of receiving loads in all four directions: radial, reverse-radial and lateral directions.

Reverse-radial direction      Radial direction

The basic load ratings are uniform in the four directions (radial, reverse-radial and lateral directions), and their actual values are provided in the dimensional table\*1 for HMG.

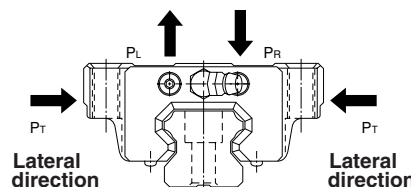

## Equivalent Load

When the LM block of model HMG receives loads in all directions simultaneously, the equivalent load is obtained from the equation below.

$$P_E = P_R (P_L) + P_T$$

where

- |                            |     |                             |     |
|----------------------------|-----|-----------------------------|-----|
| $P_E$ : Equivalent load    | [N] | $P_R$ : Radial load         | [N] |
| · Radial direction         |     | $P_L$ : Reverse-radial load | [N] |
| · Reverse-radial direction |     | $P_T$ : Lateral load        | [N] |
| · Lateral direction        |     |                             |     |

**\*1: Basic dynamic load rating (C)**

It refers to a load with a constant magnitude and direction under which the rated life (L) of a group of identical LM Guide units independently operating is 50 km.

# Service life

The service life of an LM Guide is subject to variations even under the same operational conditions. Therefore, it is necessary to use the rated life defined below as a reference value for obtaining the service life of the LM Guide.

## Rated life

The rated life means the total travel distance that 90% of a group of units of the same LM Guide model can achieve without flaking (scale-like exfoliation on the metal surface) after individually running under the same conditions.

## Service life time

Once the rated life (L) has been obtained, the service life time can be obtained using the equation on the right if the stroke length and the number of reciprocations are constant.

$$L = \left( \frac{f_H \cdot f_T \cdot f_C}{f_W} \cdot \frac{C}{P_C} \right)^3 \times 50$$

- L : Rated life [km]
- C : Basic dynamic load rating\*\* [N]
- P<sub>C</sub> : Calculated load [N]
- f<sub>H</sub> : Hardness factor (see Fig. 1)
- f<sub>T</sub> : Temperature factor (see Fig. 2)
- f<sub>C</sub> : Contact factor (see Table 1)
- f<sub>W</sub> : Load factor (see Table 2)

$$L_h = \frac{L \times 10^6}{2 \times \ell_s \times n_1 \times 60}$$

- L<sub>h</sub> : Service life time [h]
- ℓ<sub>s</sub> : Stroke length [mm]
- n<sub>1</sub> : No. of reciprocations per min [min<sup>-1</sup>]

### f<sub>H</sub> : Hardness factor

To ensure the achievement of the optimum load capacity of the LM Guide, the raceway hardness must be between 58 and 64 HRC.

At hardness below this range, the basic dynamic and static load ratings decrease. Therefore, the rating values must be multiplied by the respective hardness factors (f<sub>H</sub>).

Since the LM Guide has sufficient hardness, the f<sub>H</sub> value for the LM Guide is normally 1.0 unless otherwise specified.

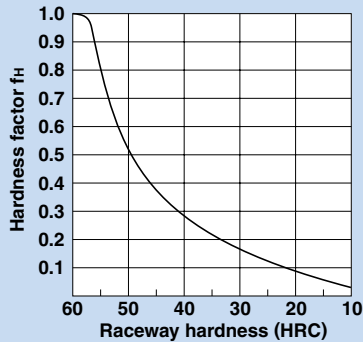

Fig. 1

### f<sub>C</sub> : Contact factor

When multiple LM blocks are used in close contact with each other, it is difficult to achieve uniform load distribution due to moment loads and mounting-surface accuracy. When using multiple blocks in close contact with each other, multiply the basic load rating (C or C<sub>s</sub>) by the corresponding contact factor indicated in Table 1.

Note: When uneven load distribution is expected in a large machine, consider using a contact factor from Table 1.

Table 1 Contact Factor (f<sub>C</sub>)

Number of blocks used in close contact	Contact factor f <sub>C</sub>
2	0.81
3	0.72
4	0.66
5	0.61
6 or more	0.6
Normal use	1

### f<sub>T</sub> : Temperature factor

Since the service temperature of Caged Ball LM Guides is normally 80°C or below, the f<sub>T</sub> value is 1.0.

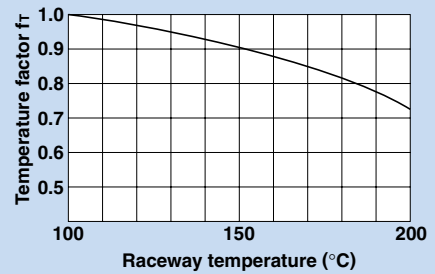

Fig. 2

### f<sub>W</sub> : Load factor

In general, reciprocating machines tend to produce vibrations or impact during operation. It is especially difficult to accurately determine all vibrations generated during high-speed operation and impacts produced each time the machine starts and stops. Therefore, where the effects of speed and vibration are estimated to be significant, divide the basic dynamic load rating (C) by a load factor selected from Table 2, which contains empirically obtained data.

Table 2 Load Factor (f<sub>W</sub>)

Vibration/impact	Speed [V]	f <sub>W</sub>
Faint	Very slow V ≤ 0.25m/s	1 to 1.2
Weak	Slow 0.25 < V ≤ 1m/s	1.2 to 1.5
Moderate	Medium 1 < V ≤ 2m/s	1.5 to 2
Strong	Fast V > 2m/s	2 to 3.5

## Radial Clearance Standard

Since the radial clearance of an LM Guide greatly affects the running accuracy, load carrying capacity and rigidity of the LM Guide, it is important to select an appropriate clearance according to the application.

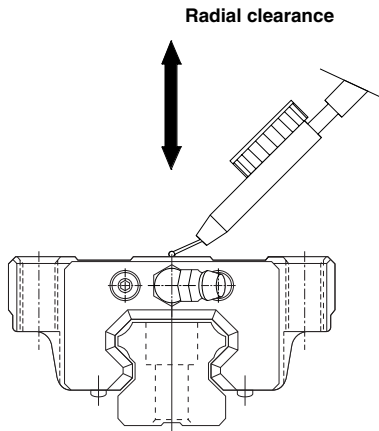

In general, selecting a negative clearance (i.e., a preload\*1 is applied) while taking into account possible vibrations and impact generated from reciprocating motion favorably affects the service life and the accuracy.

Unit:  $\mu\text{m}$

Model No.	Indication symbol	Normal	Light load
	No symbol	C1	
15	- 4 to +2	-12 to - 4	
25	- 6 to +3	-16 to - 6	
35	- 8 to +4	-22 to - 8	
45	-10 to +5	-25 to -10	
65	-14 to +7	-32 to -14	

## Accuracy Standard

The accuracy of Straight-Curved Guide HMG is specified in terms of running parallelism (\*2), dimensional tolerance for height and width, and height and width difference between a pair (\*3, \*4) when two or more LM blocks are used on one rail or when two or more rails are mounted on the same plane. (A clearance occurs in the curved area.)

The accuracy of model HMG is defined model numbers as indicated in the table below.

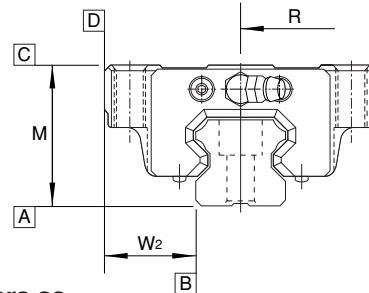

Unit: mm

Model No.	Accuracy standard	Normal grade
	Item	No symbol
15	Dimensional tolerance for height M	$\pm 0.1$
	Difference in height M	0.02
	Dimensional tolerance for width $W_2$	$\pm 0.1$
	Difference in width $W_2$	0.02
	Running parallelism of surface C against surface A	as shown in the table below
	Running parallelism of surface D against surface B	as shown in the table below
25 35	Dimensional tolerance for height M	$\pm 0.1$
	Difference in height M	0.02
	Dimensional tolerance for width $W_2$	$\pm 0.1$
	Difference in width $W_2$	0.03
	Running parallelism of surface C against surface A	as shown in the table below
	Running parallelism of surface D against surface B	as shown in the table below
45 65	Dimensional tolerance for height M	$\pm 0.1$
	Difference in height M	0.03
	Dimensional tolerance for width $W_2$	$\pm 0.1$
	Difference in width $W_2$	0.03
	Running parallelism of surface C against surface A	as shown in the table below
	Running parallelism of surface D against surface B	as shown in the table below

### \*1: Preload

Preload is an internal load applied to the rolling elements (balls) of an LM block in advance in order to increase its rigidity.

The clearance of all model HMG units is adjusted to the designated value before being shipped. Therefore, it is unnecessary to adjust the preload.

### \*2: Running parallelism

It refers to the parallelism error between the LM block and the LM rail datum plane when the LM block travels the whole length of the LM rail with the LM rail secured on the reference datum plane using bolts.

### \*3: Difference in height M

It indicates the difference between the minimum and maximum values of height (M) of each of the LM blocks used on the same plane in combination.

### \*4: Difference in width $W_2$

It indicates the difference between the minimum and maximum values of the width ( $W_2$ ) between each of the LM blocks, mounted on one LM rail in combination, and the LM rail.

### LM Rail Length and Running Parallelism for Models HMG

Unit:  $\mu\text{m}$

LM rail length [mm]		Running Parallelism Values
Above	Or less	
—	125	30
125	200	37
200	250	40
250	315	44
315	400	49
400	500	53

Unit:  $\mu\text{m}$

LM rail length [mm]		Running Parallelism Values
Above	Or less	
500	630	58
630	800	64
800	1000	70
1000	1250	77
1250	1600	84
1600	2000	92

## Shoulder Height of the Mounting Base and the Corner Radius

Normally, the mounting base for the LM rail and the LM block has a datum plane on the side face of the shoulder of the base in order to allow easy installation and highly accurate positioning.

The corner of the mounting shoulder must be machined to have a recess, or machined to be smaller than the corner radius "r," to prevent interference with the chamfer of the LM rail or the LM block.

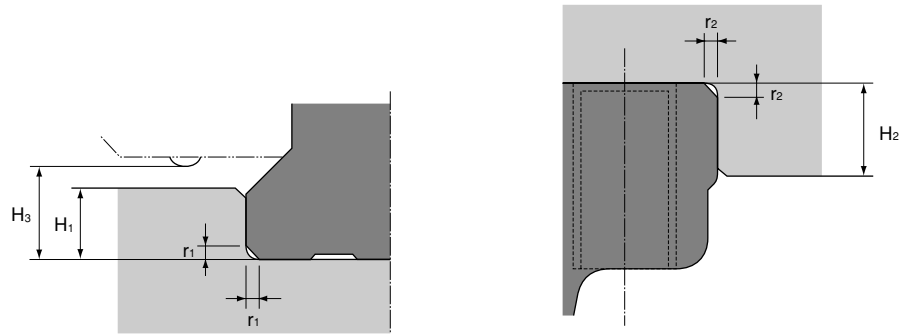

**Shoulder for the LM rail**

**Shoulder for the LM block**

Unit: mm

Model No.	Corner radius for the LM rail $r_1$ (max)	Corner radius for the LM block $r_2$ (max)	Shoulder height for the LM rail $H_1$	Shoulder height for the LM block $H_2$	$H_3$
15	0.5	0.5	3	4	3.5
25	1	1	5	5	5.5
35	1	1	6	6	7.5
45	1	1	8	8	10
65	1.5	1.5	10	10	14

## Examples of Table Mechanisms

The Straight-Curved Guide HMG requires a rotating mechanism and a slide mechanism for the table to rotate through the curved sections when 2 or more rails are used or when 2 or more LM blocks are connected on a single rail. Refer to Fig. 1 for examples of such mechanisms.

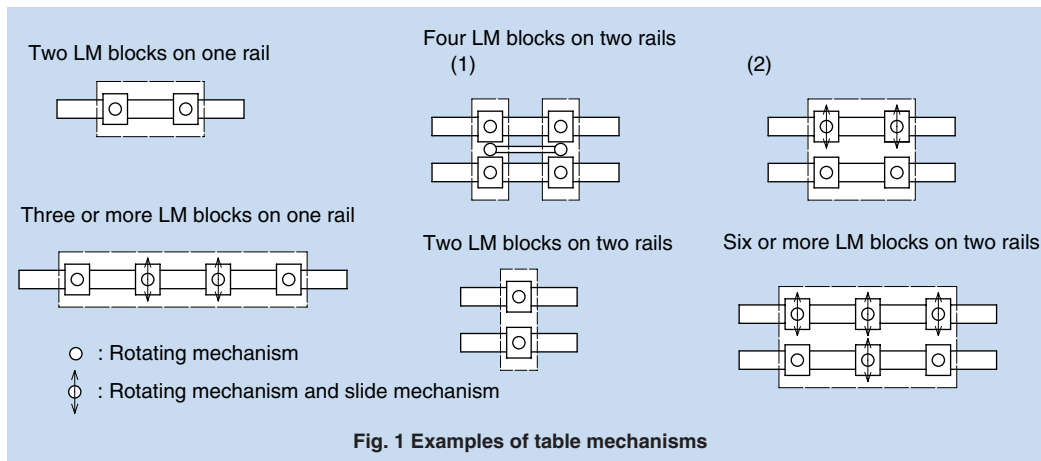
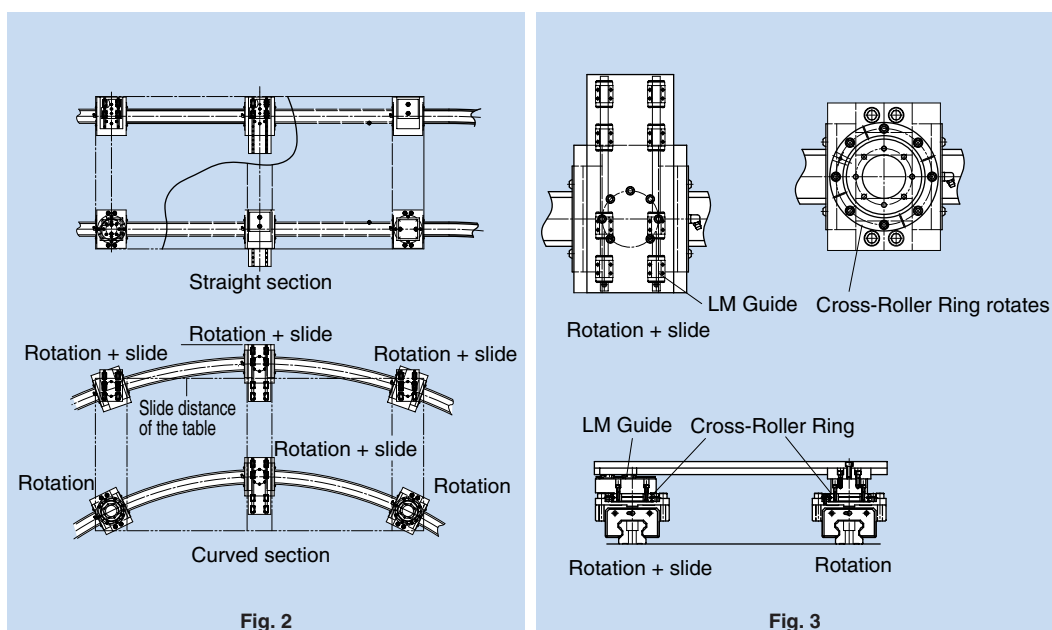

Fig. 2 shows examples of designing a table when HMG units are used on multiple rails. A Straight-Curved Guide requires a rotating mechanism and a slide mechanism since the table is decentered when an LM block transits from a straight section to a curved section. The amount of eccentricity differs according to the radius of the curved section and the LM block span. Therefore, it is necessary to design the system in accordance with the corresponding specifications.

Fig. 3 shows detail drawings of the slide and rotating mechanisms. In Fig. 3, LM Guides are used in the slide mechanism and Cross-Roller Rings in the rotating mechanism to achieve smooth sliding and rotating motions.

For driving the Straight-Curved Guide, belt drives and chain drives are available.



# Model HMG

## Dimensional Table for Model HMG

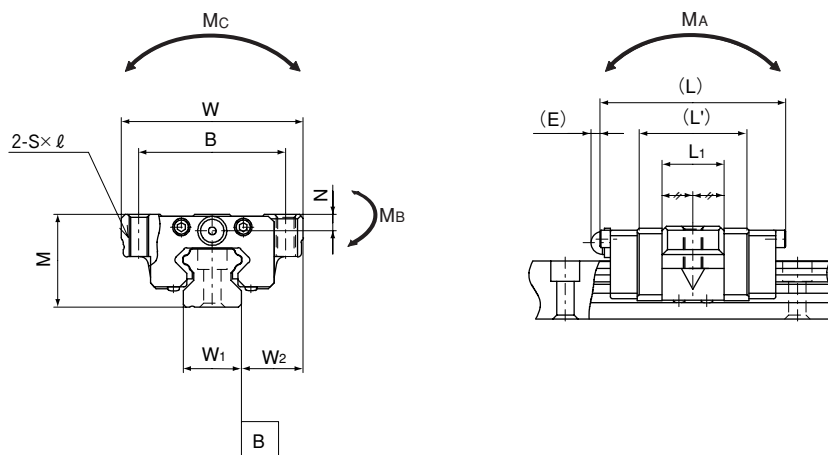

Model No.	Outer dimensions				LM block dimensions					LM rail dimensions			
	M	W	L	L'	B	S×ℓ	L <sub>1</sub>	N	E	Straight rail			Height
										W <sub>1</sub>	W <sub>2</sub>	F	M <sub>1</sub>
<b>HMG15A</b>	24	47	48	28.8	38	M5×11	16	4.3	5.5	15	16	60	15
<b>HMG25A</b>	36	70	62.2	42.2	57	M8×16	25.6	6	12	23	23.5	60	22
<b>HMG35A</b>	48	100	80.6	54.6	82	M10×21	32.6	8	12	34	33	80	29
<b>HMG45A</b>	60	120	107.6	76.6	100	M12×25	42.6	10	16	45	37.5	105	38
<b>HMG65A</b>	90	170	144.4	107.4	142	M16×37	63.4	19	16	63	53.5	150	53

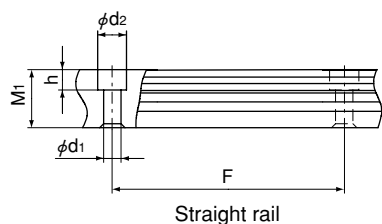

Straight rail

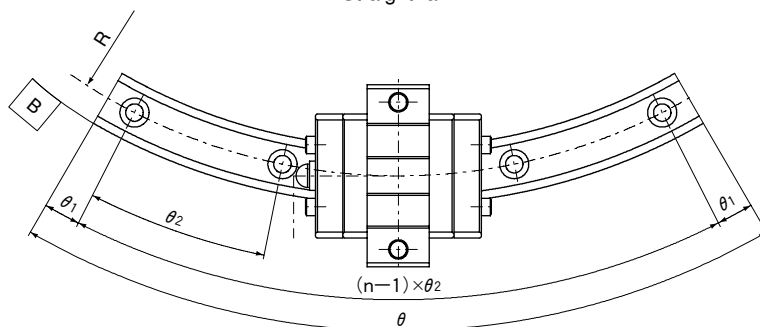

Curved rail

Unit: mm

LM rail dimensions						Basic dynamic load rating(C)	Basic static load rating(Co)	
Mounting hole	Curved rail						Resultant load(C)[kN]	Straight section(Cost)[kN]
d <sub>1</sub> ×d <sub>2</sub> ×h	R	n	θ°	θ <sub>1</sub> °	θ <sub>2</sub> °			
4.5×7.5×5.3	150	3	60	7	23	2.56	4.23	0.44
	300	5	60	6	12			
	400	7	60	3	9			
7×11×9	500	9	60	2	7	9.41	10.8	6.7
	750	12	60	2.5	5			
	1000	15	60	2	4			
9×14×12	600	7	60	3	9	17.7	19	11.5
	800	11	60	2.5	5.5			
	1000	12	60	2.5	5			
	1300	17	60	2	3.5			
14×20×17	800	8	60	2	8	28.1	29.7	18.2
	1000	10	60	3	6			
	1200	12	60	2.5	5			
	1600	15	60	2	4			
18×26×22	1000	8	60	2	8	66.2	66.7	36.2
	1500	10	60	3	6			
	2000	12	45	0.5	4			
	2500	13	45	1.5	3.5			
	3000	10	30	1.5	3			



In an application design with one LM block used on one rail, if a moment is applied, its operation may be affected.

If a moment is applied, we recommend using multiple LM blocks on one rail.

Table 1 shows the static permissible moment value per LM block in the M<sub>A</sub>, M<sub>B</sub> and M<sub>C</sub> directions.

Table 1 Static permissible moment of HMG

Unit: kN-m

Model No.	M <sub>A</sub> 		M <sub>B</sub> 		M <sub>C</sub> 	
	Straight section	Curved section	Straight section	Curved section	Straight section	Curved section
HMG15	0.008	0.007	0.008	0.01	0.027	0.003
HMG25	0.1	0.04	0.1	0.05	0.11	0.07
HMG35	0.22	0.11	0.22	0.12	0.29	0.17
HMG45	0.48	0.2	0.48	0.22	0.58	0.34
HMG65	1.47	0.66	1.47	0.73	1.83	0.94

# HMG TYPE

## Joint LM rails

### ● Specifications of unevenness of the joint

Since accuracy tolerance in LM rail installation affects the product's service life, mount LM rails so that the unevenness of each joint is within the specification shown in Table 1. For a joint between curved rails, and a joint between curved and joint rails, we recommend using pins as shown in Fig. 1. When joining those rails, place the pins on the outside, press the rails toward the pins, and then adjust the joint to eliminate or minimize the unevenness using adjusting screws from the inside.

Table 1 Specifications for unevenness of the joint Unit: mm

Model No.	Ball raceway, side face	Top face	Max clearance of the joint
	a	b	c
15	0.01	0.02	0.6
25	0.01	0.02	0.7
35	0.01	0.02	1
45	0.01	0.02	1.3
65	0.01	0.02	1.3

Note: Place the pins on the outside and the presser bolts on the inside.

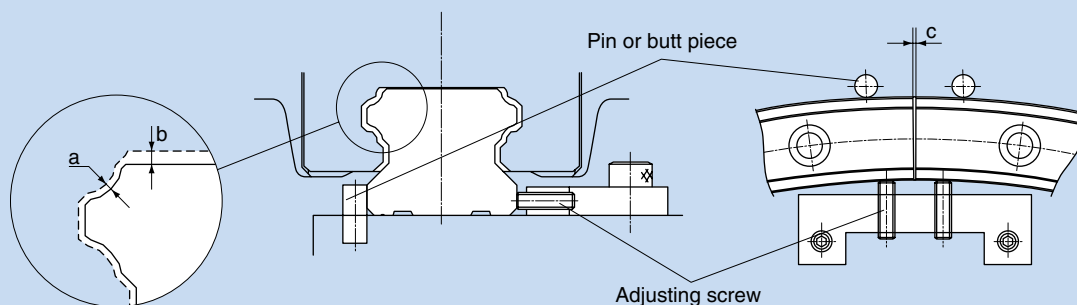

Fig. 1 Use of butt pieces

### ● Curved sections

With HMG, there is a clearance in each curved section for a structural reason. Therefore, HMG may not be used where highly accurate feed is required. In addition, the curved section cannot receive a large moment. If a large moment is applied, it is necessary to increase the number of LM blocks or LM rails. For specific values of permissible moments, see Table 1 on page 22.

## LM rail Joints

HMG requires connection rails when LM blocks move from straight to curved sections or where R is inverted such as rails connected in an S shape. Take this into account when designing a system in such applications.

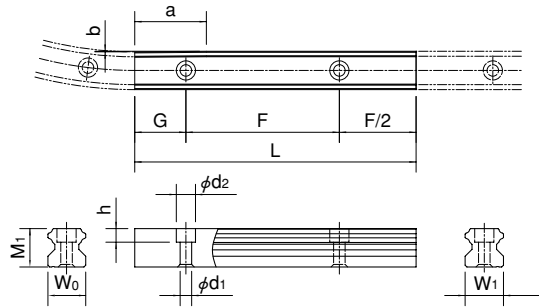

Table 2 Dimensions of rail joints

Unit: mm

Model No.	Dimensions of a joint rail							
	Height M <sub>1</sub>	Pitch F	Mounting hole d <sub>1</sub> ×d <sub>2</sub> ×h	Width		Taper length a	Taper depth b	Radius R
15A	15	60	4.5×7.5×5.3	15	14.78	28	0.22	150
					14.89		0.11	300
					14.92		0.08	400
25A	22	60	7×11×9	23	22.83	42	0.17	500
					22.89		0.11	750
					22.92		0.08	1000
35A	29	80	9×14×12	34	33.77	54	0.23	600
					33.83		0.17	800
					33.86		0.14	1000
					33.9		0.1	1300
45A	38	105	14×20×17	45	44.71	76	0.29	800
					44.77		0.23	1000
					44.81		0.19	1200
					44.86		0.14	1600
65A	53	150	18×26×22	63	62.48	107	0.52	1000
					62.66		0.34	1500
					62.74		0.26	2000
					62.8		0.2	2500
					62.83		0.17	3000

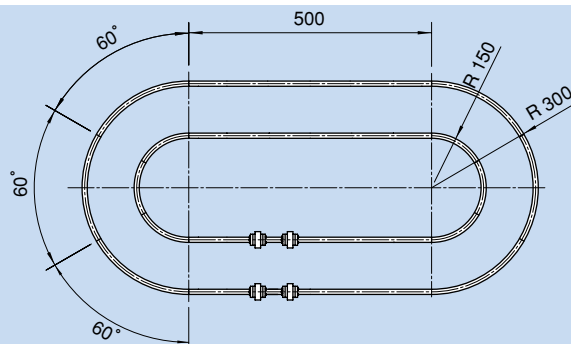

Fig.2 Example of model number

### Example of model number coding

When 2 axes are used

**HMG15A 2 UU C1+1000L T+60/150R 6T+60/300R 6T- II**

- 1 Model number
- 2 Number of LM blocks per axis
- 3 Seal symbol
- 4 Clearance symbol
- 5 Overall straight LM rail length per axis
- 6 Straight LM rail joint symbol
- 7 Center angle of an inward curved LM rail
- 8 Radius of an inward curved LM rail
- 9 Number of inward curved LM rails connected
- 10 Center angle of an outward curved LM rail
- 11 Radius of an outward curved LM rail
- 12 Number of outward curved LM rails connected
- 13 Number of axes

**Note** - This model number indicates that an LM block and an LM rail constitute one set (i.e., the required number of sets when 2 rails are used in parallel is 2).

- HMG does not have a seal as standard.

Fig. 2 represents the above example of model number coding.

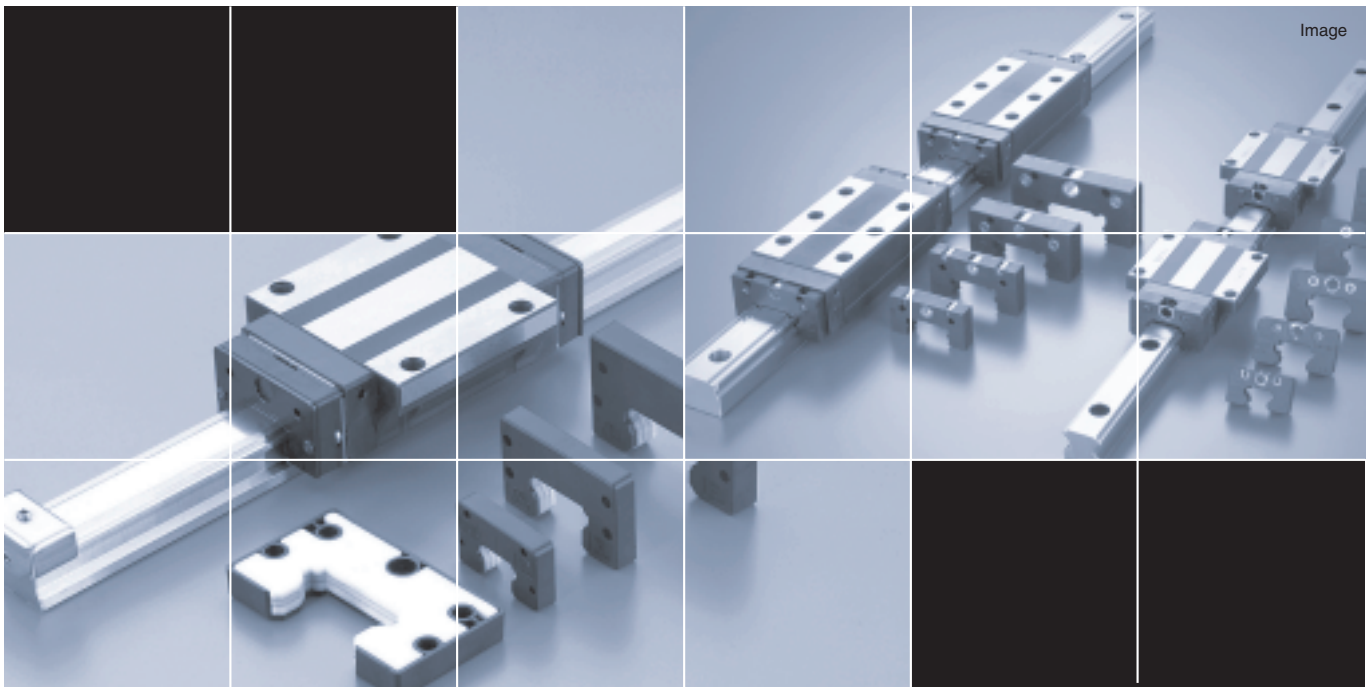

# HMG OPTIONS

## Options

For model HMG, dust-prevention accessories are available. Make a selection according to the application and the installation site.

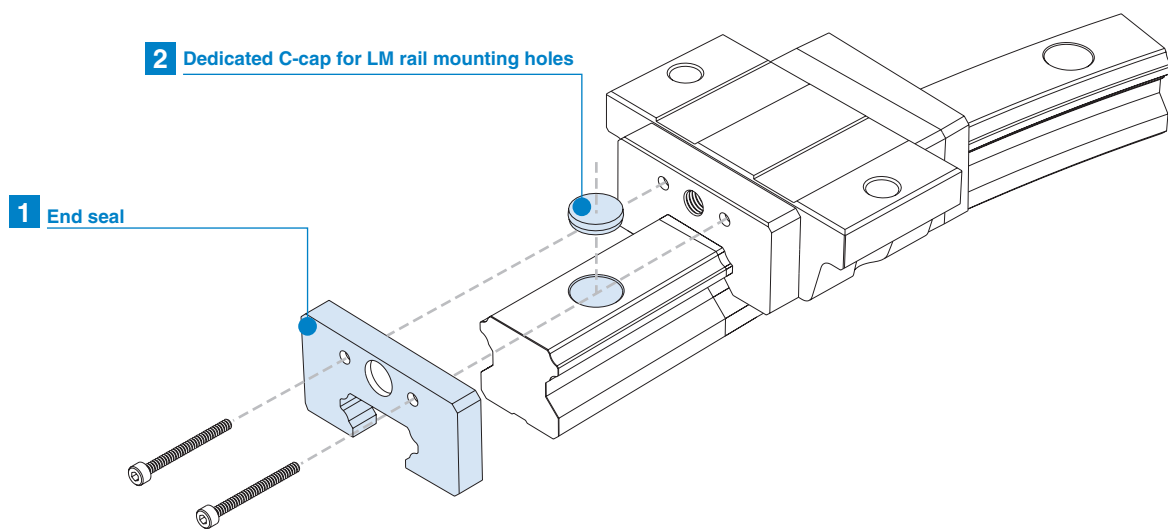

## Dust Prevention Accessories

When foreign matter enters an LM system, it will cause abnormal wear or shorten the service life. It is necessary to prevent foreign matter from entering the system. Therefore, when possible entrance of foreign matter is predicted, it is important to select an effective sealing device or dust-prevention device that meets the working conditions.

### 1 Seal

As a standard, high wear-resistant end seals are used.

If desiring a dust-prevention accessory, specify it with the corresponding symbol indicated in table 2. For the supported model numbers for dust-prevention accessories and the overall LM block length with a dust-prevention accessory attached (dimension L), see table 3.

#### Seal resistance value

For the maximum seal resistance value per LM block when a lubricant is applied on seal HMG ... UU, refer to the corresponding value provided in table 1.

Table 1 Maximum Seal Resistance  
Value of Seal HMG ... UU  
Unit: N

Model No.	Seal resistance value
15	3
25	6
35	8
45	12
65	40

Note: These specification values represent values of one block (2 seals).

Table 2 Symbol of Dust Prevention Accessory for Model HMG

Symbol	Dust prevention accessory
UU	With end seal

Table 3 Overall LM Block Length (Dimension L) of Model HM  
with a Dust Prevention Accessory Attached  
Unit: mm

Model No.	UU
15	48
25	62.2
35	80.6
45	107.6
65	144.4

### 2 Dedicated C-cap for LM Rail Mounting Holes

If any of the LM rail mounting holes of an LM Guide is filled with cutting chips or foreign matter, they may enter the LM block structure. Entrance of such foreign matter can be prevented by covering each LM rail mounting hole with the dedicated cap so that the top of the mounting holes are on the same level as the LM rail top face.

The dedicated C-cap for LM rail mounting holes is highly durable since it uses a special synthetic resin with high oil resistance and high wear resistance. When placing an order, specify the desired cap type with the corresponding cap number indicated in the table on the right.

Model No.	C-Cap model No.	Bolt used	Major dimensions mm	
			D	H
15	C 4	M 4	7.8	1
25	C 6	M 6	11.4	2.7
35	C 8	M 8	14.4	3.7
45	C12	M12	20.5	4.7
65	C16	M16	26.5	5.7

### End seal

Used in locations exposed to dust.

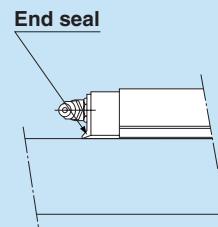

### Dedicated C-cap

It prevents cutting chips from entering the LM rail mounting holes.

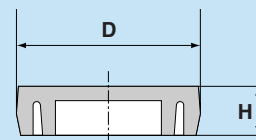

# THK R Guide Model HCR / Straight-Curved Guide Model HMG

## Precautions on use

### ● Handling

- Disassembling components may cause dust to enter the system or degrade mounting accuracy of parts. Do not disassemble the product.
- Tilting an LM block or LM rail may cause them to fall by their own weight.
- Dropping or hitting the LM Guide may damage it. Giving an impact to the LM Guide could also cause damage to its function even if the guide looks intact.

### ● Lubrication

- Thoroughly remove anti-corrosion oil and feed lubricant before using the product.
- Do not mix lubricants of different physical properties.
- In locations exposed to constant vibrations or in special environments such as clean rooms, vacuum and low/high temperature, normal lubricants may not be used. Contact THK for details.
- When planning to use a special lubricant, contact THK before using it.
- When adopting oil lubrication, the lubricant may not be distributed throughout the LM system depending on the mounting orientation of the system. Contact THK for details.
- Lubrication interval varies according to the service conditions. Contact THK for details.

### ● Precautions on Use

- Entrance of foreign matter may cause damage to the ball circulating path or functional loss. Prevent foreign matter, such as dust or cutting chips, from entering the system.
- When planning to use the LM system in an environment where coolant penetrates the LM block, it may cause trouble to product functions depending on the type of coolant. Contact THK for details.
- Do not use the LM system at temperature of 80°C or higher. When desiring to use the system at temperature of 80°C or higher, contact THK in advance.
- If foreign matter adheres to the LM system, replenish the lubricant after cleaning the product. For available types of detergent, contact THK.
- When using the LM Guide with an inverted mount, breakage of the endplate due to an accident or the like may cause balls to fall out and the LM block to come off from the LM rail and fall. In these cases, take preventive measures such as adding a safety mechanism for preventing such falls.
- When using the LM system in locations exposed to constant vibrations or in special environments such as clean rooms, vacuum and low/high temperature, contact THK in advance.
- When removing the LM block from the LM rail and then replacing the block, an LM block mounting/removing jig that facilitates such installation is available. Contact THK for details.

### ● Storage

- When storing the LM Guide, enclose it in a package designated by THK and store it in a horizontal orientation while avoiding high temperature, low temperature and high humidity.

### ● “LM GUIDE,” and “” are registered trademarks of THK CO., LTD.

- The photo may differ slightly in appearance from the actual product.
  - The appearance and specifications of the product are subject to change without notice. Contact THK before placing an order.
  - Although great care has been taken in the production of this catalog, THK will not take any responsibility for damage resulting from typographical errors or omissions.
  - For the export of our products or technologies and for the sale for exports, THK in principle complies with the foreign exchange law and the Foreign Exchange and Foreign Trade Control Law as well as other relevant laws.
- For export of THK products as single items, contact THK in advance.

All rights reserved

# THK CO., LTD.

HEAD OFFICE 3-11-6, NISHI-GOTANDA, SHINAGAWA-KU, TOKYO 141-8503 JAPAN  
INTERNATIONAL SALES DEPARTMENT PHONE:+81-3-5434-0351 FAX:+81-3-5434-0353  
Global site : <http://www.thk.com/>

#### NORTH AMERICA

- THK America, Inc.  
● HEADQUARTERS  
Phone:+1-847-310-1111 Fax:+1-847-310-1271  
● CHICAGO OFFICE  
Phone:+1-847-310-1111 Fax:+1-847-310-1182  
● NORTH EAST OFFICE  
Phone:+1-845-369-4035 Fax:+1-845-369-4909  
● ATLANTA OFFICE  
Phone:+1-770-840-7990 Fax:+1-770-840-7897  
● LOS ANGELES OFFICE  
Phone:+1-949-955-3145 Fax:+1-949-955-3149  
● SAN FRANCISCO OFFICE  
Phone:+1-925-455-8948 Fax:+1-925-455-8965  
● DETROIT OFFICE  
Phone:+1-248-858-9330 Fax:+1-248-858-9455  
● TORONTO OFFICE  
Phone:+1-905-820-7800 Fax:+1-905-820-7811

#### SOUTH AMERICA

THK Brasil LTDA  
Phone:+55-11-3767-0100 Fax:+55-11-3767-0100

#### EUROPE

- THK GmbH  
● EUROPEAN HEADQUARTERS  
Phone:+49-2102-7425-0 Fax:+49-2102-7425-217  
● DÜSSELDORF OFFICE  
Phone:+49-2102-7425-0 Fax:+49-2102-7425-299

#### ● FRANKFURT OFFICE

- Phone:+49-2102-7425-650 Fax:+49-2102-7425-699  
● STUTTGART OFFICE  
Phone:+49-7150-9199-0 Fax:+49-7150-9199-888  
● MÜNCHEN OFFICE  
Phone:+49-8937-0616-0 Fax:+49-8937-0616-26  
● U.K. OFFICE  
Phone:+44-1908-30-3050 Fax:+44-1908-30-3070  
● ITALY MILANO OFFICE  
Phone:+39-039-284-2079 Fax:+39-039-284-2527  
● ITALY BOLOGNA OFFICE  
Phone:+39-051-641-2211 Fax:+39-051-641-2230  
● SWEDEN OFFICE  
Phone:+46-8-445-7630 Fax:+46-8-445-7639  
● AUSTRIA OFFICE  
Phone:+43-7229-51400 Fax:+43-7229-51400-79  
● SPAIN OFFICE  
Phone:+34-93-652-5740 Fax:+34-93-652-5746  
● TURKEY OFFICE  
Phone:+90-216-362-4050 Fax:+90-216-569-7150  
● PRAGUE OFFICE  
Phone:+420-2-41025-100 Fax:+420-2-41025-199  
THK Europe B.V.  
● EINDHOVEN OFFICE  
Phone:+31-040-290-9500 Fax:+31-040-290-9599  
THK France S.A.S.  
Phone:+33-4-3749-1400 Fax:+33-4-3749-1401

#### CHINA

- THK (CHINA) CO., LTD.  
● HEADQUARTERS  
Phone:+86-411-8733-7111 Fax:+86-411-8733-7000  
● SHANGHAI OFFICE  
Phone:+86-21-6219-3000 Fax:+86-21-6219-9890  
● BEIJING OFFICE  
Phone:+86-10-8441-7277 Fax:+86-10-6590-3557  
● CHENGDU OFFICE  
Phone:+86-28-8526-8025 Fax:+86-28-8525-6357  
● GUANGZHOU OFFICE  
Phone:+86-20-8523-8418 Fax:+86-20-3801-0456  
THK (SHANGHAI) CO., LTD.  
Phone:+86-21-6275-5280 Fax:+86-21-6219-9890

#### TAIWAN

- THK TAIWAN CO., LTD.  
● TAIPEI HEAD OFFICE  
Phone:+886-2-2888-3818 Fax:+886-2-2888-3819  
● TAICHUNG OFFICE  
Phone:+886-4-2359-1505 Fax:+886-4-2359-1506  
● TAINAN OFFICE  
Phone:+886-6-289-7668 Fax:+886-6-289-7669

#### KOREA

- SEOUL REPRESENTATIVE OFFICE  
Phone:+82-2-3468-4351 Fax:+82-2-3468-4353

#### SINGAPORE

- THK LM SYSTEM Pte. Ltd.  
Phone:+65-6884-5500 Fax:+65-6884-5550

#### INDIA

- BANGALORE REPRESENTATIVE OFFICE  
Phone:+91-80-2330-1524 Fax:+91-80-2314-8226