



LM Guide

Structural Member Rail
Four-way Equal Load Type

JR



Structural Member Rail, Four-way Equal Load Type LM Guide

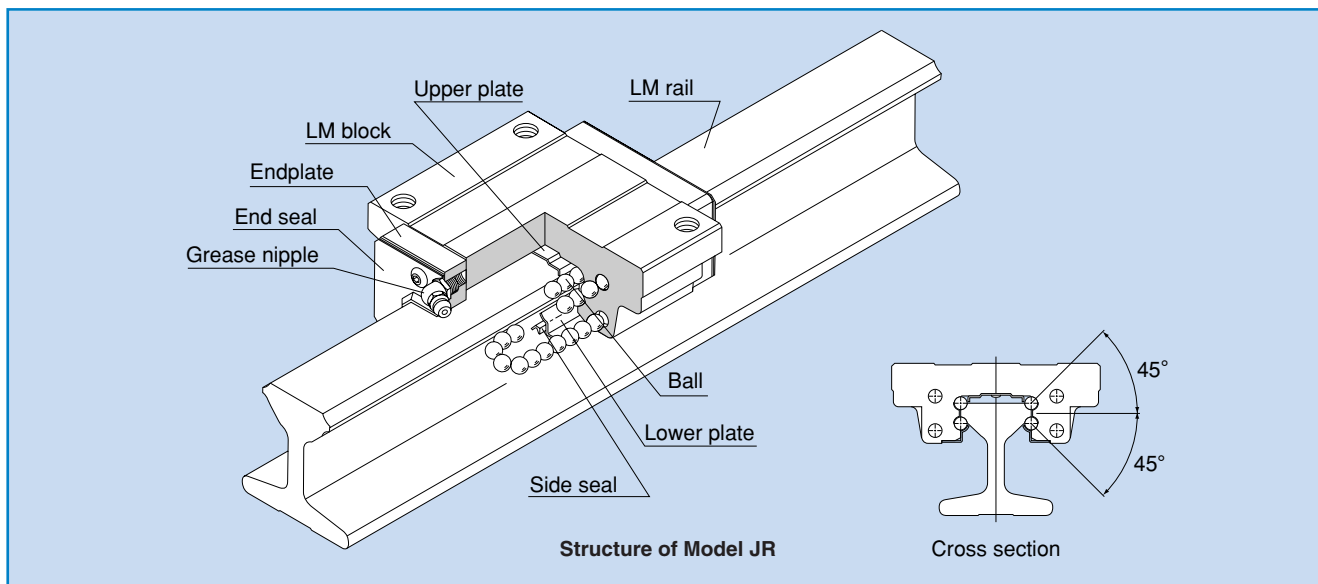

Balls roll in four rows of raceways precision-ground on an LM rail and an LM block, and endplates incorporated in the LM block allow the balls to circulate. Since retainer plates hold the balls, they do not fall out even if the LM rail is pulled out.

Model JR uses the same LM block as model HSR, which has a proven track record and is highly reliable. The LM rail has a sectional shape with high bending rigidity, and therefore can be used as a structural member.

Unlike the conventional LM Guide, whose LM rail was secured onto the base with bolts when installed, model JR's LM rail is integrated with the mounting base, and the top of the LM rail has the same structure as LM Guide model HSR. The lower part of the LM rail has a hardness of HRC25 or less, making it easy to cut the rail and enabling the rail to be welded.

When welding the rail, we recommend using welding rods compliant with JIS D 5816 (suggested manufacturer and model number: Kobelco LB-52).

● 4-way equal load

Each row of balls is placed at a contact angle of 45° so that the rated loads applied to the LM block are uniform in the four directions (radial, reverse-radial and lateral directions), enabling the LM Guide to be used in all orientations and in extensive applications.

● Can be mounted even under rough conditions

Since the central part of the LM rail is thinner than the top and the bottom, even if the parallelism between two rails is poor the LM rail is capable of absorbing the error by bending inward or outward.

● Sectional shape with high flexural rigidity

Since the LM rail has a sectional shape with high flexural rigidity, it can also be used as a structural member. In addition, even when the LM rail is partially secured or supported in cantilever, the distortion is minimal.

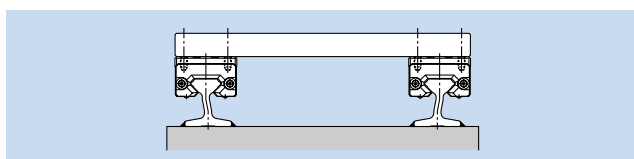

● Geometric Moment of Inertia of the LM Rail

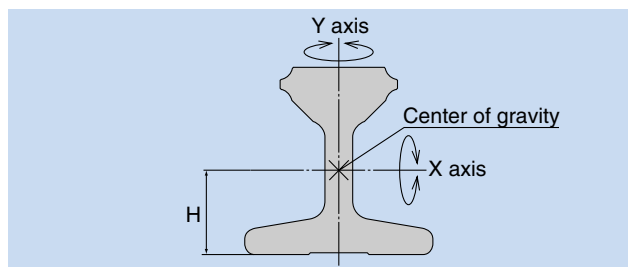

	Geometric moment of inertia I [$\times 10^6$ mm ⁴]		Section modulus Z [$\times 10^4$ mm ³]		Height of center of gravity H [mm]
	X axis rotation	Y axis rotation	X axis rotation	Y axis rotation	
JR 25	1.9	0.51	0.69	0.21	19.5
JR 35	4.26	1.32	1.43	0.49	24.3
JR 45	12.1	3.66	3.31	1.04	33.1
JR 55	27.6	6.54	5.89	1.4	43.3

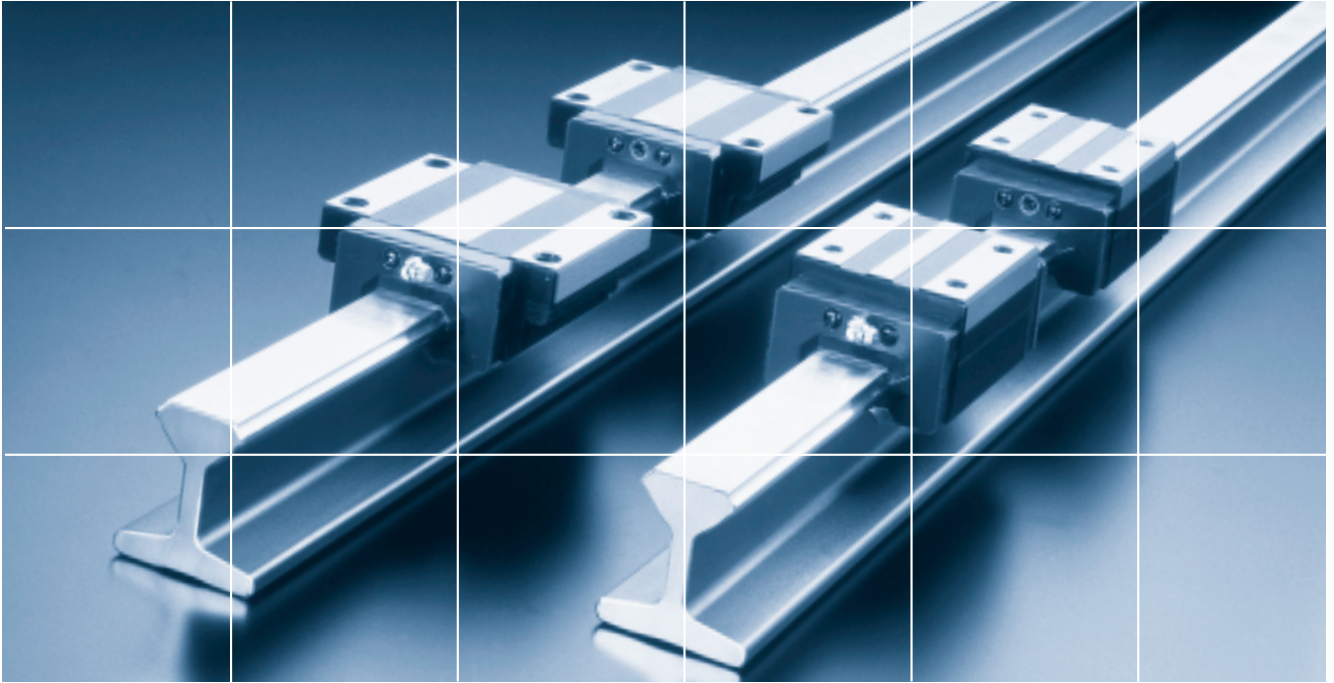

JR Outline

Model JR - Product Overview

Since the central part of the LM rail is thinly structured, the LM Guide is capable of absorbing an error and achieving smooth motion even if the parallelism between the 2 rails is insufficient.

Since the LM rail has a sectional shape with high bending rigidity, this model can be used as a structural member.

Major applications Automated warehouse / garage / gantry robot / FMS traveling rail / elevator / conveyance system / welding machine / lifter / crane / forklift / coating machine / shield tunneling machine / stage setting

Model JR-A

The flange of the LM block has tapped holes.

- JR 25A ● JR 45A
- JR 35A ● JR 55A

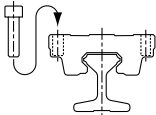
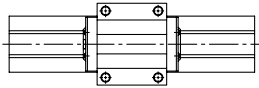

Model JR-B

The flange of the LM block has through holes. This model is used in places where the table cannot have through holes for mounting.

- JR 25B ● JR 45B
- JR 35B ● JR 55B

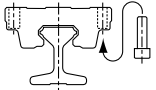
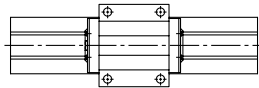

Model JR-R

The LM block has a smaller width (W) and has tapped holes. This model is used in places where the space for table width is limited.

- JR 25R ● JR 45R
- JR 35R ● JR 55R

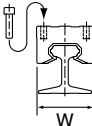
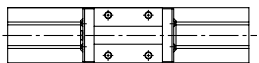

*1: Dimensional table for model JR
 Model JR
 → pages 9-10

Rated Loads in All Directions

Model JR is capable of receiving loads in all four directions: radial, reverse-radial and lateral directions.

The basic load ratings are uniform in the four directions (radial, reverse-radial and lateral directions), and their actual values are provided in the dimensional table*1 for JR.

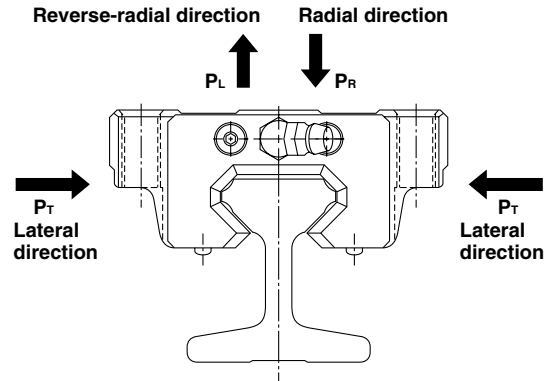

Equivalent Load

When the LM block of model JR receives loads in all directions simultaneously, the equivalent load is obtained from the equation below.

$$P_E = P_R (P_L) + P_T$$

where

P_E :Equivalent load	(N)	P_R :Radial load	(N)
·Radial direction		P_L :Reverse-radial load	(N)
·Reverse-radial direction		P_T :Lateral load	(N)
·Lateral direction			

Service life

The service life of an LM Guide is subject to variations even under the same operational conditions. Therefore, it is necessary to use the rated life defined below as a reference value for obtaining the service life of the LM Guide.

Rated life

The rated life means the total travel distance that 90% of a group of units of the same LM Guide model can achieve without flaking (scale-like exfoliation on the metal surface) after individually running under the same conditions.

Service life time

Once the rated life (L) has been obtained, the service life time can be obtained using the equation on the right if the stroke length and the number of reciprocations are constant.

*1: Basic dynamic load rating (C)

It refers to a load with a constant magnitude and direction under which the rated life (L) of a group of identical LM Guide units independently operating is 50 km.

$$L = \left(\frac{f_H \cdot f_T \cdot f_C}{f_W} \cdot \frac{C}{P_C} \right)^3 \times 50$$

- L : Rated life (km)
- C : Basic dynamic load rating*1 (N)
- P_C : Calculated load (N)
- f_H : Hardness factor (see Fig. 1)
- f_T : Temperature factor (see Fig. 2)
- f_C : Contact factor (see Table 1)
- f_W : Load factor (see Table 2)

$$L_h = \frac{L \times 10^6}{2 \times \ell_s \times n_1 \times 60}$$

- L_h : Service life time (h)
- ℓ_s : Stroke length (mm)
- n₁ : No. of reciprocations per min (min⁻¹)

f_H : Hardness factor

To ensure the achievement of the optimum load capacity of the LM Guide, the raceway hardness must be between 58 and 64 HRC. At hardness below this range, the basic dynamic and static load ratings decrease. Therefore, the rating values must be multiplied by the respective hardness factors (f_H). Since the LM Guide has sufficient hardness, the f_H value for the LM Guide is normally 1.0 unless otherwise specified.

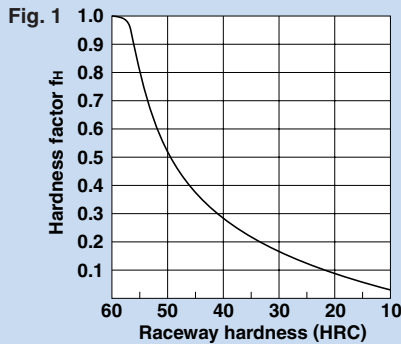

f_T : Temperature factor

Since the service temperature of Caged Ball LM Guides is normally 80°C or below, the f_T value is 1.0.

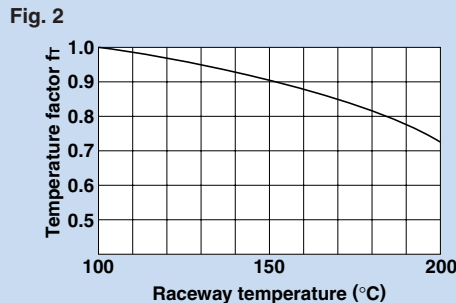

f_C : Contact factor

When multiple LM blocks are used in close contact with each other, it is difficult to achieve uniform load distribution due to moment loads and mounting-surface accuracy. When using multiple blocks in close contact with each other, multiply the basic load rating (C or C₀) by the corresponding contact factor indicated in Table 1.

Note: When uneven load distribution is expected in a large machine, consider using a contact factor from Table 1.

Table 1 Contact Factor (f_C)

Number of blocks used in close contact	Contact factor f _C
2	0.81
3	0.72
4	0.66
5	0.61
6 or more	0.6
Normal use	1

f_W : Load factor

In general, reciprocating machines tend to produce vibrations or impact during operation. It is especially difficult to accurately determine all vibrations generated during high-speed operation and impacts produced each time the machine starts and stops. Therefore, where the effects of speed and vibration are estimated to be significant, divide the basic dynamic load rating (C) by a load factor selected from Table 2, which contains empirically obtained data.

Table 2 Load Factor (f_W)

Vibration/impact	Speed (V)	f _W
Faint	Very slow V ≤ 0.25m/s	1 to 1.2
Weak	Slow 0.25 < V ≤ 1m/s	1.2 to 1.5
Moderate	Medium 1 < V ≤ 2m/s	1.5 to 2
Strong	Fast V > 2m/s	2 to 3.5

***1: Preload**

Preload is an internal load applied to the rolling elements (balls, rollers, etc.) of an LM block in advance in order to increase its rigidity.

The clearance of all model JR units is adjusted to the designated value before being shipped. Therefore, it is unnecessary to adjust the preload.

Radial Clearance Standard

Since the radial clearance of an LM Guide greatly affects the running accuracy, load carrying capacity and rigidity of the LM Guide, it is important to select an appropriate clearance according to the application.

In general, selecting a negative clearance (i.e., a preload*1 is applied) while taking into account possible vibrations and impact generated from reciprocating motion favorably affects the service life and the accuracy.

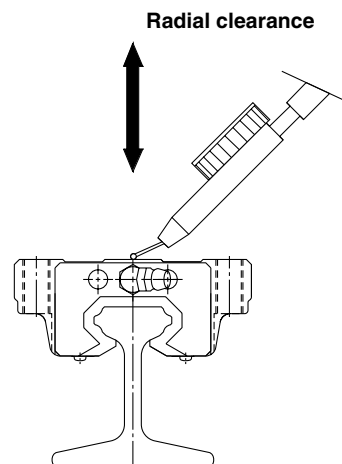

Unit: μm

Model No.	Indication symbol	Normal
		No symbol
25		0 to +30
35		0 to +30
45		0 to +50
55		0 to +50

Accuracy Standard

The accuracy of model JR is specified in terms of running parallelism (*1), dimensional tolerance for height and width, and height and width difference between a pair (*2, *3) when two or more LM blocks are used on one rail or when two or more rails are mounted on the same plane.

Accuracies of model JR are defined by model numbers as indicated in the table below.

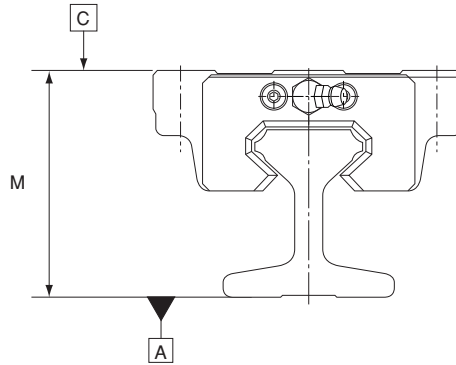

***1: Running parallelism**

It refers to the parallelism error between the LM block and the LM rail datum plane when the LM block travels the whole length of the LM rail with the LM rail secured on the reference datum plane using bolts.

***2: Difference in height M**

It indicates the difference between the minimum and maximum values of height (M) of each of the LM blocks used on the same plane in combination.

***3: Difference in width W₂**

It indicates the difference between the minimum and maximum values of the width (W₂) between each of the LM blocks, mounted on one LM rail in combination, and the LM rail.

Unit: mm

Model No.	Accuracy standard	Normal grade
	Item	No symbol
25 35	Difference in height M	0.05
	Running parallelism of surface C against surface A	ΔC (as shown in the figure below)
45 55	Difference in height M	0.06
	Running parallelism of surface C against surface A	ΔC (as shown in the figure below)

LM Rail Length and Running Parallelism for Model JR

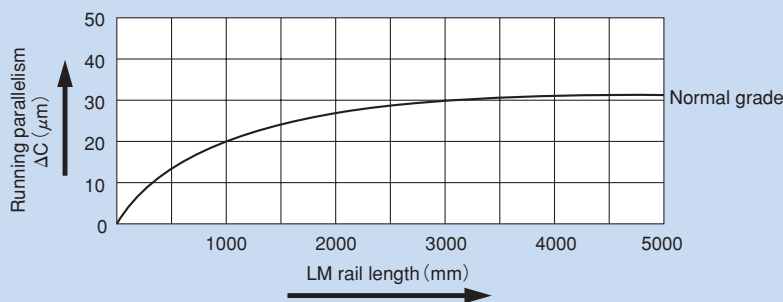

Shoulder Height of the Mounting Base and the Corner Radius

Normally, the mounting base for the LM rail and the LM block has a datum plane on the side face of the shoulder of the base in order to allow easy installation and highly accurate positioning.

The corner of the mounting shoulder must be machined to have a recess, or machined to be smaller than the corner radius "r," to prevent interference with the chamfer of the LM rail or the LM block.

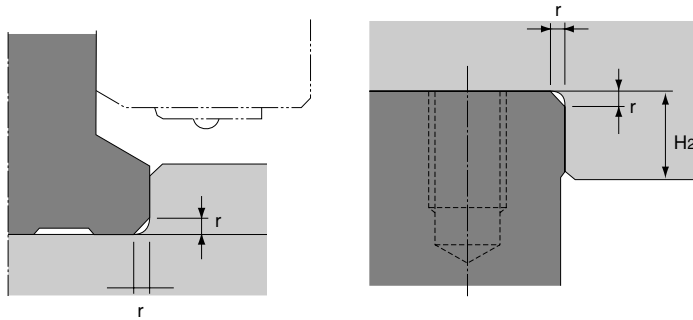

Unit: mm

Model No.	Corner radius r (max)	Shoulder height for the LM block H ₂
25	1	5
35	1	6
45	1	8
55	1.5	10

Error Allowance in the Parallelism Between Two Rails

The following table shows error allowances in parallelism (P) between two rails that will not affect the service life in normal operation.

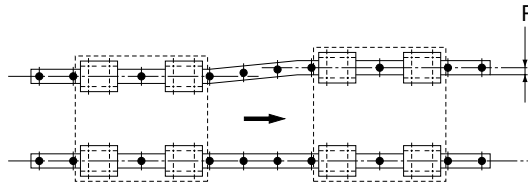

Unit: μm

Model No.	—
25	100
35	200
45	300
55	400

Error Allowance in Vertical Level Between Two Rails

The values in the table each indicate the error allowances in vertical level between two rails per 500 mm of the axis-to-axis distance, and are proportional to the axis-to-axis distances.

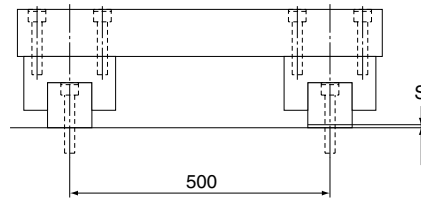

Unit: μm

Model No.	—
25	400
35	500
45	800
55	1000

Models JR-A/JR-B/JR-R

Dimensional Table for Models JR-A/JR-B/JR-R

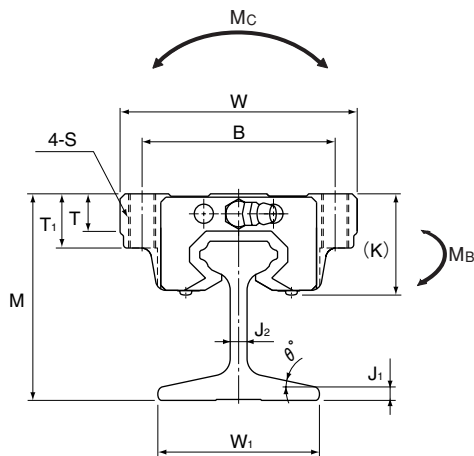

Models JR25, 35-A

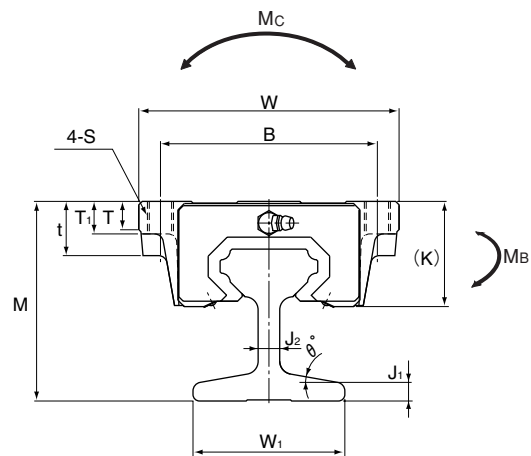

Models JR45, 55-A

Model No.	External dimensions			LM block dimensions												
	Height	Width	Length	B	C	H	S×ℓ	L _i	t	T	T ₁	K	N	E	Grease nipple	
	M	W	L													
JR 25A	61	70		57	45	—	M8 **		—	11	16	30.5	6			
JR 25B	61	70	83.1	57	45	7	—	59.5	16	11	10	30.5	6	12	B-M6F	
JR 25R	65	48		35	35	—	M6×8		—	9	—	34.5	10			
JR 35A	73	100		82	62	—	M10 **		—	12	21	40	8			
JR 35B	73	100	113.6	82	62	9	—	80.4	21	12	13	40	8	12	B-M6F	
JR 35R	80	70		50	50	—	M8×12		—	11.7	—	47.4	15			
JR 45A	92	120		100	80	—	M12 **		25	13	15	50	10			
JR 45B	92	120	145	100	80	11	—	98	25	13	15	50	10	16	B-PT1/8	
JR 45R	102	86		60	60	—	M10×17		—	15	—	59.4	20			
JR 55A	114	140		116	95	—	M14 **		29	13.5	17	57	11			
JR 55B	114	140	165	116	95	14	—	118	29	13.5	17	57	11	16	B-PT1/8	
JR 55R	124	100		75	75	—	M12×18		—	20.5	—	67	21			

Note "*" indicates a through hole.

Example of model number coding

JR35 R 2 UU +1000L

1 2 3 4 5

1 Model number 2 Type of LM block 3 No. of LM blocks used on the same rail
4 Dust prevention accessory symbol (see page 13) 5 LM rail length (in mm)

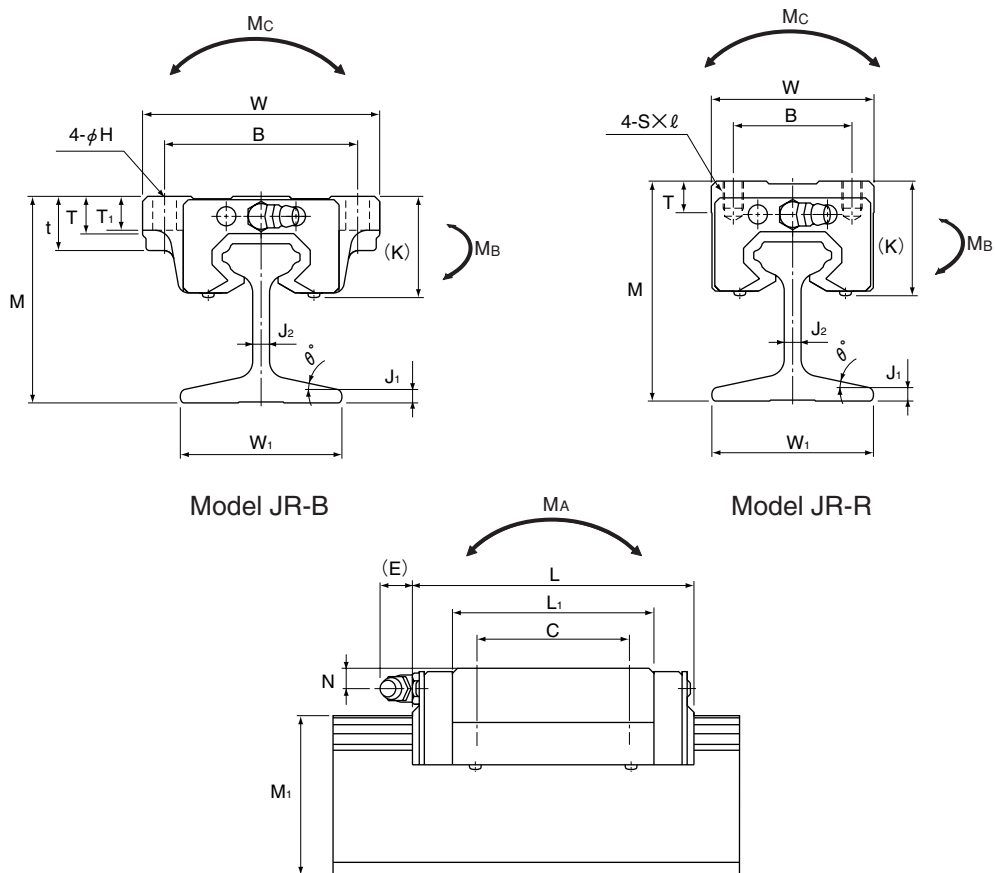

Unit: mm

					Basic load rating		Static permissible moment kN·m*					Mass	
Width W ₁	J ₁	J ₂	θ°	Height M ₁	C kN	C ₀ kN	M _A		M _B		M _C 1 block	LM block kg	LM rail kg/m
							1 block	2 blocks in close contact	1 block	2 blocks in close contact			
48	4	5	12	47	19.9	34.4	0.307	1.71	0.307	1.71	0.344	0.59 0.59 0.54	4.2
54	7	8	10	54	37.3	61.1	0.782	3.93	0.782	3.93	0.905	1.6 1.6 1.5	8.6
70	8	10	10	70	60	95.6	1.42	7.92	1.42	7.92	1.83	2.8 2.8 2.6	15.2
93	4.8	11.6	12	90	88.5	137	2.45	13.2	2.45	13.2	3.2	4.5 4.5 4.3	18.3



Static permissible moment*:

1 block: static permissible moment value with 1 LM block

2 blocks: static permissible moment value with 2 blocks closely contacting with each other

JR

Standard Length and Maximum Length of the LM Rail

The table below shows the standard LM rail lengths and the maximum lengths of model JR variations. If the maximum length of the desired LM rail exceeds them, connected rails will be used. Contact THK for details.

Standard Length and Maximum Length of the LM Rail for Model JR

Unit: mm

Model No.	JR 25	JR 35	JR 45	JR 55
Standard LM rail length (L ₀)	1000	1000	1000	1000
	1500	2000	2000	2000
	2000	4000	4000	4000
Max length	2000	4000	4000	4000

Note 1: If connected rails are not allowed and a greater length than the maximum values above is required, contact THK.

Note 2: For connecting two or more rails, a metal fitting like the one shown in the figure below is available. Contact THK for details.

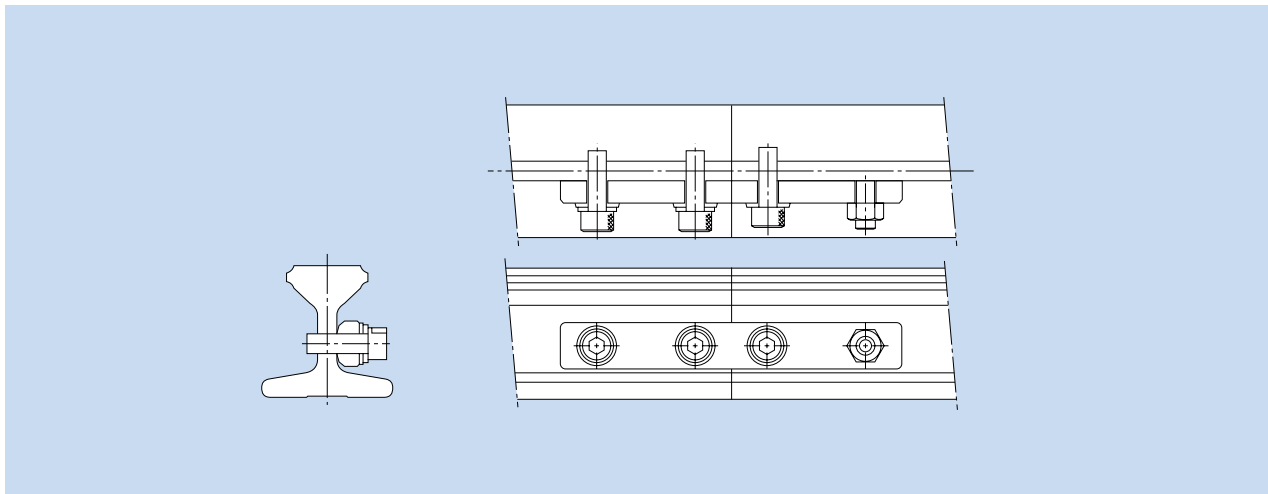

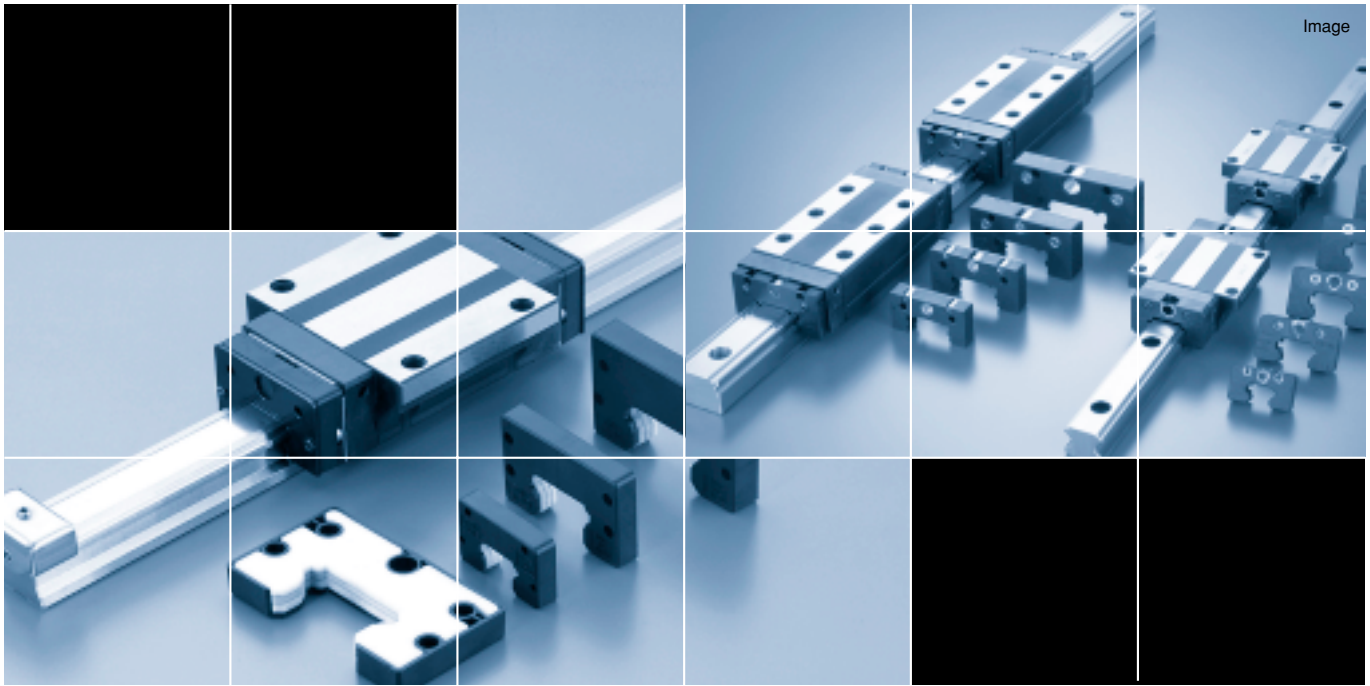

JR OPTIONS

Options

For model JR, dust-prevention accessories are available. Make a selection according to the application and the installation site.

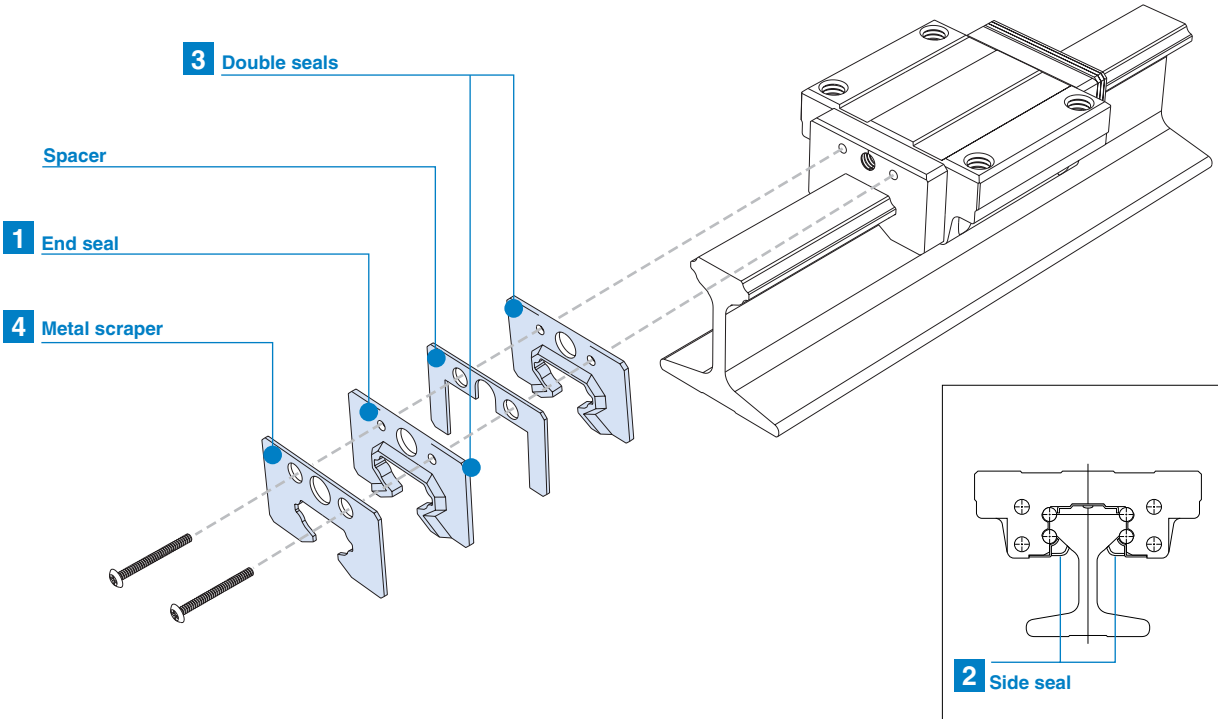

Dust Prevention Accessories

When foreign matter enters an LM system, it will cause abnormal wear or shorten the service life. It is necessary to prevent foreign matter from entering the system. Therefore, when possible entrance of foreign matter is predicted, it is important to select an effective sealing device or dust-prevention device that meets the working conditions.

1 End seal
Used in locations exposed to dust.

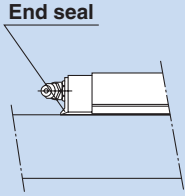

The diagram shows a cross-section of an LM rail with an end seal installed at one end. A label 'End seal' points to the seal component.

2 Side seal
Used in locations where dust may enter the LM block from the side or bottom surface, such as vertical, horizontal and inverted mounts.

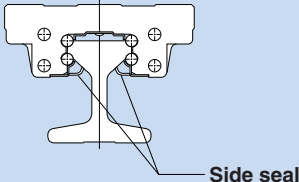

The diagram shows a cross-section of an LM rail with a side seal installed on its side. A label 'Side seal' points to the seal component.

3 Double seals
Used in locations exposed to much dust or many cutting chips.

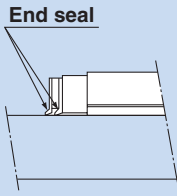

The diagram shows a cross-section of an LM rail with two seals installed at one end. A label 'End seal' points to the seal component.

4 Metal scraper
Used in locations where welding spatter may adhere to the LM rail.

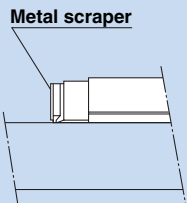

The diagram shows a cross-section of an LM rail with a metal scraper installed on its side. A label 'Metal scraper' points to the scraper component.

1 to 4 Seals and a Scraper

Seals

Highly wear-resistant end seals made of special resin rubber and side seals for increased dust-prevention effect are available.

If desiring a dust-prevention accessory, specify it with the corresponding symbol indicated in table 2.

For the supported model numbers for dust-prevention accessories and the overall LM block length with a dust-prevention accessory attached (dimension L), see table 3.

Seal resistance value

For the maximum seal resistance value per LM block when a lubricant is applied on seals JR ∙ ∙ SS, refer to the corresponding value provided in table 1.

Table 1 Maximum Seal Resistance Value of Seals JR ∙ ∙ SS Unit: N

Model No.	Seal resistance value
JR 25	3.9
JR 35	11.8
JR 45	19.6
JR 55	19.6

Table 2 Symbols of Dust Prevention Accessories for Model JR

Symbol	Dust prevention accessory
UU	With end seal
SS	With end seal + side seal
DD	With double seals + side seal
ZZ	With end seal + side seal + metal scraper
KK	With double seals + side seal + metal scraper

Table 3 Overall LM Block Length (Dimension L) of Model JR with a Dust Prevention Accessory Attached Unit: mm

Model No.	UU	SS	DD	ZZ	KK
25A/B/R	83.1	83.1	90.7	89.4	97
35A/B/R	113.6	113.6	125.6	122	134*
45A/B/R	145	145	159	150.8	164.8*
55A/B/R	165	165	175.4	170.4	180.8*

Note: "*" indicates available, but does not support a grease nipple. Contact THK for details.

Accessories for LM Rail Clamps

Accessories for clamps used to secure the LM rail are available.

5 LM Rail Clamping Piece JB

Unit: mm

Model No.	Mounting dimensions		Clamper dimensions									Bolt used
	A	B	C	D	E	F	G	H	R	J	θ°	
JB 25	57	78	25	7	10.5	15	10	3.8	R2	25	10	M 6
JB 35	72	102	35	9	15	24	12	3.1	R2	32	8	M 8
JB 45	90	130	45	11	20	30	16	5.4	R2	40	8	M10
JB 55	115	155	50	14	20	30	17	8.2	R2	50	10	M12

LM rail clamping piece JB

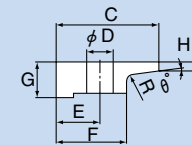
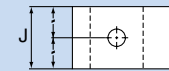
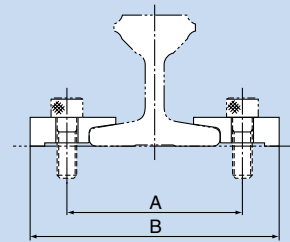

6 LM Rail Clamping Iron Plate JT

Unit: mm

Model No.	Mounting dimensions		Clamper dimensions						Bolt used
	K	L	N	P	S	T	U	V	
JT 25	57	79	25	11	10	4	7	25	M 6
JT 35	65	91	27	13	13	4.5	9	40	M 8
JT 45	84	114	33	15	16	6	11	50	M10
JT 55	110	148	50	19	15	6	14	50	M12

LM rail clamping iron plate JT

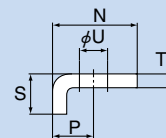
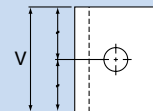
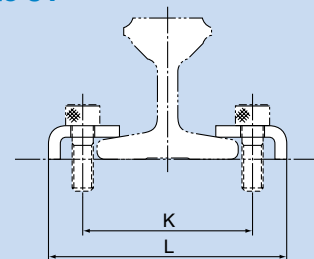

THK LM Guide Model JR

Precautions on use

● Handling

- Disassembling components may cause dust to enter the system or degrade mounting accuracy of parts. Do not disassemble the product.
- Tilting an LM block or LM rail may cause them to fall by their own weight.
- Dropping or hitting the LM Guide may damage it. Giving an impact to the LM Guide could also cause damage to its function even if the guide looks intact.

● Lubrication

- Thoroughly remove anti-corrosion oil and feed lubricant before using the product.
- Do not mix lubricants of different physical properties.
- In locations exposed to constant vibrations or in special environments such as clean rooms, vacuum and low/high temperature, normal lubricants may not be used. Contact THK for details.
- When planning to use a special lubricant, contact THK before using it.
- When adopting oil lubrication, the lubricant may not be distributed throughout the LM system depending on the mounting orientation of the system. Contact THK for details.
- Lubrication interval varies according to the service conditions. Contact THK for details.

● Precautions on Use

- Entrance of foreign matter may cause damage to the ball circulating path or functional loss. Prevent foreign matter, such as dust or cutting chips, from entering the system.
- When planning to use the LM system in an environment where coolant penetrates the LM block, it may cause trouble to product functions depending on the type of coolant. Contact THK for details.
- Do not use the LM system at temperature of 80°C or higher. When desiring to use the system at temperature of 80°C or higher, contact THK in advance.
- If foreign matter adheres to the LM system, replenish the lubricant after cleaning the product. For available types of detergent, contact THK.
- When using the LM Guide with an inverted mount, breakage of the endplate due to an accident or the like may cause balls to fall out and the LM block to come off from the LM rail and fall. In these cases, take preventive measures such as adding a safety mechanism for preventing such falls.
- When using the LM system in locations exposed to constant vibrations or in special environments such as clean rooms, vacuum and low/high temperature, contact THK in advance.
- When removing the LM block from the LM rail and then replacing the block, an LM block mounting/removing jig that facilitates such installation is available. Contact THK for details.

● Storage

- When storing the LM Guide, enclose it in a package designated by THK and store it in a horizontal orientation while avoiding high temperature, low temperature and high humidity.

● “LM Guide,” “Ball Cage,” “,” and “QZ” are registered trademarks of THK CO., LTD.

- The photo may differ slightly in appearance from the actual product.
 - The appearance and specifications of the product are subject to change without notice. Contact THK before placing an order.
 - Although great care has been taken in the production of this catalog, THK will not take any responsibility for damage resulting from typographical errors or omissions.
 - For the export of our products or technologies and for the sale for exports, THK in principle complies with the foreign exchange law and the Foreign Exchange and Foreign Trade Control Law as well as other relevant laws.
- For export of THK products as single items, contact THK in advance.

All rights reserved

THK CO., LTD.

HEAD OFFICE 3-11-6, NISHI-GOTANDA, SHINAGAWA-KU, TOKYO 141-8503 JAPAN

ASIA PACIFIC SALES DEPARTMENT PHONE:(03)5434-0351 FAX:(03)5434-0353

NORTH AMERICA

CHICAGO

PHONE:(847)310-1111 FAX:(847)310-1182

NEW JERSEY

PHONE:(201)529-1950 FAX:(201)529-1962

ATLANTA

PHONE:(770)840-7990 FAX:(770)840-7897

LOS ANGELES

PHONE:(714)891-6752 FAX:(714)894-9315

SAN FRANCISCO

PHONE:(925)455-8948 FAX:(925)455-8965

BOSTON

PHONE:(781)575-1151 FAX:(781)575-9295

DETROIT

PHONE:(248)858-9330 FAX:(248)858-9455

TORONTO

PHONE:(905)712-2922 FAX:(905)712-2925

BRASIL (SÃO PAULO)

PHONE:(011)3767-0100 FAX:(011)3767-0101

EUROPE

DÜSSELDORF

PHONE:0049-(0)2102-7425-0 FAX:0049-(0)2102-7425-299

STUTTGART

PHONE:0049-(0)7150-9199-0 FAX:0049-(0)7150-9199-888

MÜNCHEN

PHONE:0049-(0)89-3706160 FAX:0049-(0)89-37061626

U.K.

PHONE:0044-(0)1908-303050 FAX:0044-(0)1908-303070

MILANO

PHONE:0039-039-2842079 FAX:0039-039-2842527

BOLOGNA

PHONE:0039-051-6412211 FAX:0039-051-6412230

SWEDEN

PHONE:0046-(0)8-4457630 FAX:0046-(0)8-4457639

AUSTRIA

PHONE:0043-(0)7229-51400 FAX:0043-(0)7229-51400-79

SPAIN

PHONE:0034-93-652-5740 FAX:0034-93-652-5746

THK FRANCE S. A. S.

PHONE:0033-(0)4-37491400 FAX:0033-(0)4-37491401

SOUTH AFRICA

PHONE:0027-(0)44-2720020 FAX:0027-(0)44-2720020

CHINA

THK SHANGHAI CO.,LTD.

PHONE:(21)6334-5131 FAX:(21)6334-5137

BEIJING

PHONE:(10)6590-3259 FAX:(10)6590-3557

THK SHOUZAN CO.,LTD.

PHONE:2376-1091 FAX:2376-0749

TAIWAN

TAIPEI

PHONE:(02)2888-3818 FAX:(02)2888-3819

TAICHUNG

PHONE:(04)2359-1505 FAX:(04)2359-1506

SOUTHERN

PHONE:(06)289-7668 FAX:(06)289-7669

KOREA (SEOUL)

PHONE:(02)3468-4351 FAX:(02)3468-4353

MALAYSIA (KUALA LUMPUR)

PHONE:(03)9287-1137 FAX:(03)9287-8071

INDIA (BANGALORE)

PHONE:(080)2330-1524 FAX:(080)2330-1524

