

KS/BS

Die-setting Ball Cage Models KS and BS

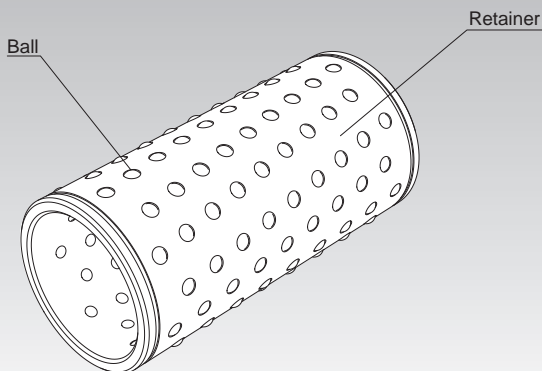

Fig.1 Structure of Die-setting Ball Cage Model KS

Structure and Features

With models KS and BS, a large number of precision steel balls (sphericity in mutual difference: 0.0005 mm) compliant with JIS B 1501 are incorporated in a lightweight, highly rigid ball cage. The balls are arranged along the circumference of the ball cage in spirals so that the ball raceways do not overlap with each other. It enables these models to be used over a long period without wear and to demonstrate high durability.

In addition, the ball pockets, which hold the balls, are finished with precision and continuously caulked with a unique process, enabling them to prevent the balls from falling. It allows the system to travel smoothly even if the ball cage is longer than the housing.

These ball cages are used in precision press die set, spinning and weaving machine, precision measuring instrument, automatic recorder, medical equipment and various machine tools.

Rated Load and Service Life

The rated loads of models KS and BS are indicated in the respective specification tables. Their service lives are obtained using the service life equation for LM Stroke model ST on **A5-4**.

Fit

When using the Die-setting Ball Cage in the guide unit of the guide post of a precision press die set, normally select a negative clearance in order to increase the accuracy and the ball cage rigidity. Table1 shows typical fitting between the hole and the shaft. Select a combination of a hole and a shaft so that the clearance does not exceed the tolerance value of the radial clearance indicated in the specification table.

Table1 Fitting between Holes and Shaft

Tolerance in hole dimensions: D	K5
Dimensional tolerance of the shaft: d	h5

Installation of the Ball Cage

Fig.2 shows examples of mounting the Die-setting Ball Cage.

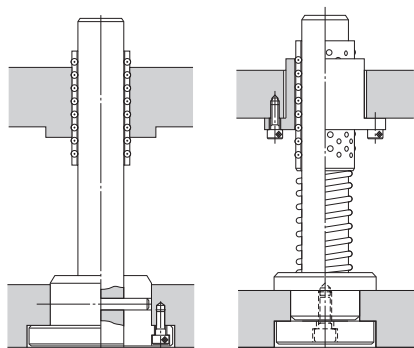
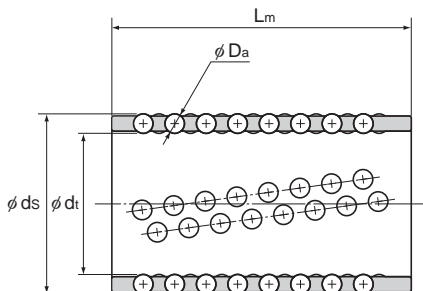

Fig.2 Example of Installation

Models KS / BS



Unit: mm

Combined model No.	Main dimensions				Radial clearance tolerance μm	Basic load rating		Mass g
	d_t	D_a (inch)	d_s	L_m		C kN	C_0 kN	
KS 1955	19	3	25	55	-7	10.3	3.82	31.7
BS 1955	19	3.175 (1/8)	25.35	55	-7	11.7	4.22	33.2
KS 2260	22	3	28	60	-7	10.7	4.22	37.6
BS 2260	22	3.175 (1/8)	28.35	60	-7	12.2	4.71	39.1
KS 2565	25	3	31	65	-7	11.7	5	45.4
BS 2565	25	3.175 (1/8)	31.35	65	-7	13.2	5.59	47.1
KS 2870	28	4	36	70	-9	18	7.65	80.4
BS 2870	28	3.969 (5/32)	35.938	70	-9	17.7	7.55	80.0
KS 3275	32	4	40	75	-9	19.7	9.12	96.5
BS 3275	32	3.969 (5/32)	39.938	75	-9	19.3	8.92	96.0
KS 3880	38	5	48	80	-10	25	12	156
BS 3880	38	4.762 (3/16)	47.525	80	-10	22.5	10.9	150

Note) The outer surface of model BS has a groove to help distinguish it from KS.
Shafts for models KS and BS are also manufactured. Contact THK for details.