

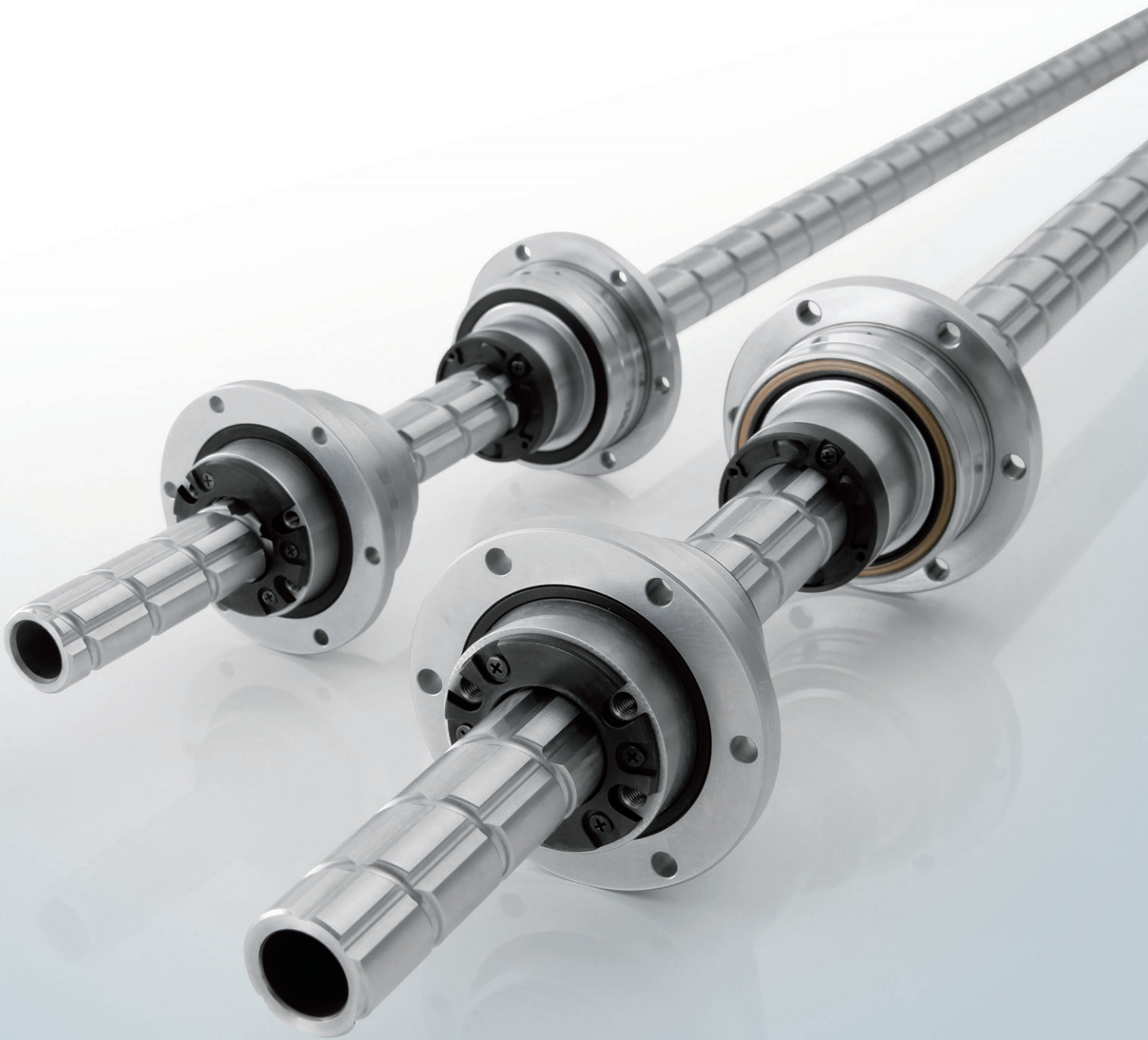

NEW

Low-Inertia Ball Screw/Spline

BNS-V/NS-V



Improves takt time of horizontal articulated robots

Enables high-speed motion, fast starts,
and quick stops

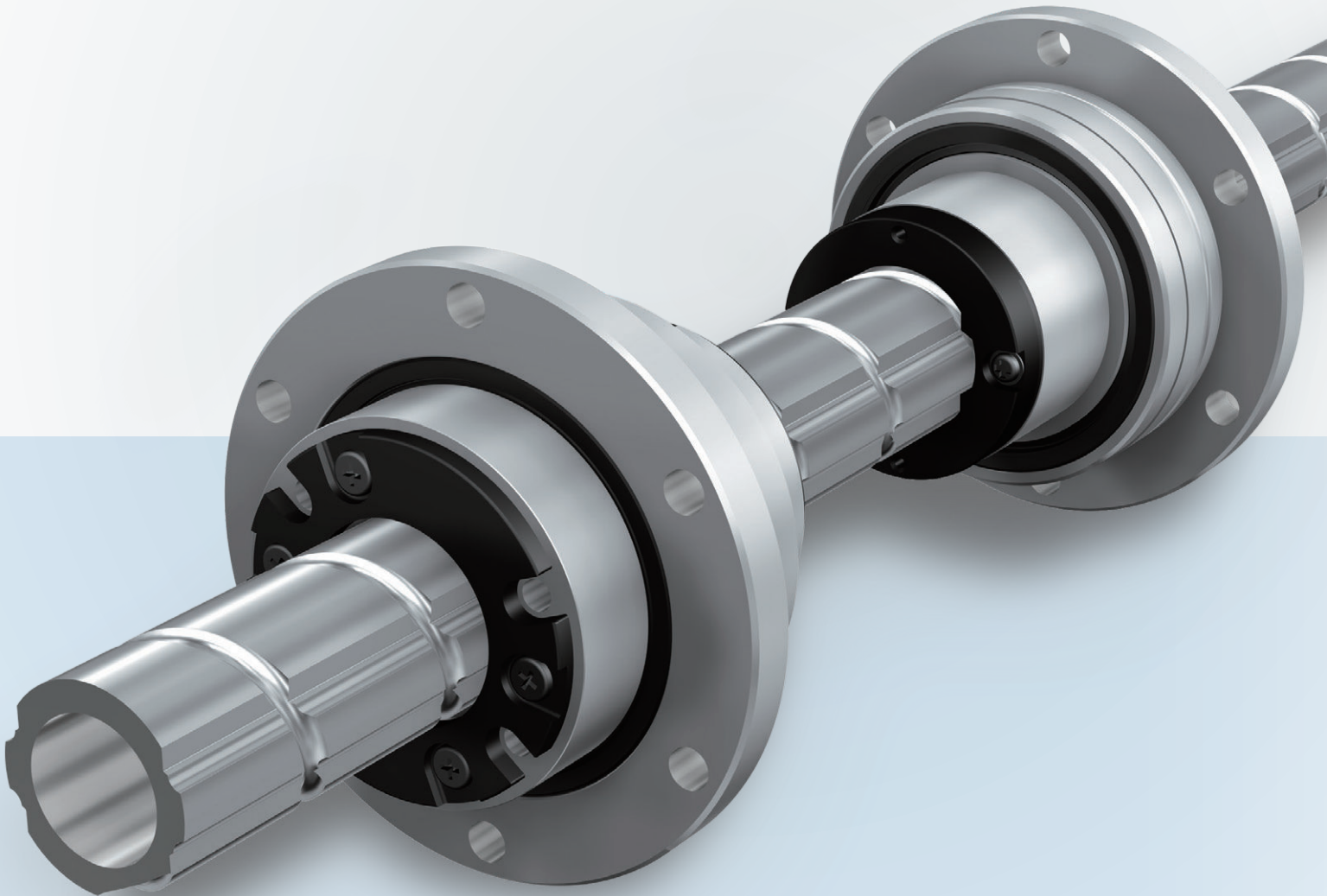

Low-Inertia Ball Screw/Spline

BNS-V / NS-V

Improves takt time of horizontal articulated robots

Inertial moment of the nut

Up to **45%**
lower

Comparison between BNS 1616A(exiting model) and BNS1616V(new model)

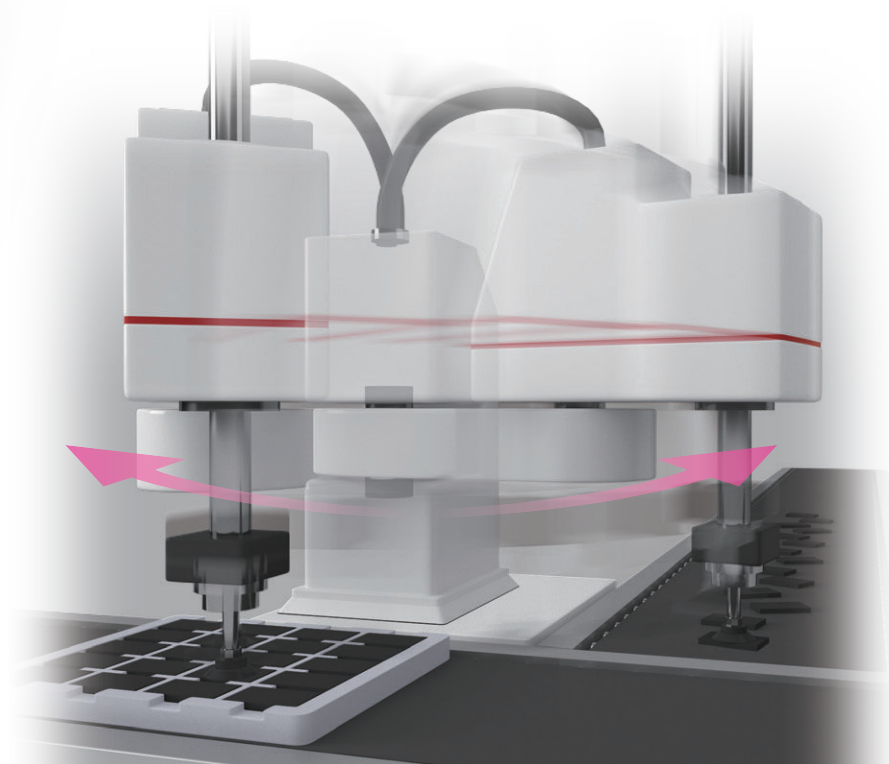

Customers are looking for low-inertia Z axes to improve the takt time of horizontal articulated robots.

This product is more compact and lightweight than its predecessors, achieving low inertia and helping to optimize designs.

Three Features That Improve Equipment Takt Time

Feature 1 Compact

Up to **16%** smaller
Size down

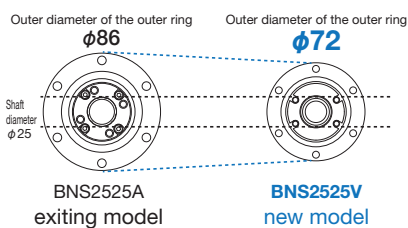

Size

The compact outer diameter enables the peripheral components of mounting devices to be smaller.

Feature 2 Lightweight

Up to **29%** lighter

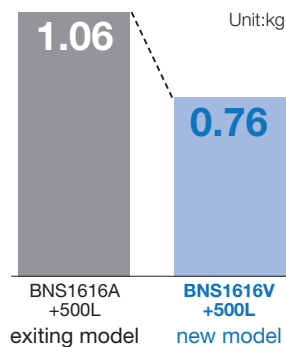

Mass

This lightweight product helps reduce the overall weight of the mounting device.

Feature 3 Low inertia

Up to **45%** less inertia

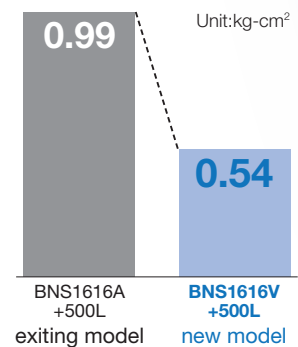

Inertial Moment of the Nut

The reduced inertial moment of the nut makes the end shaft's vertical movements faster and smoother. It also curbs rotational torque, reducing the load put on the motor.

Provides Both Precision and Speed

Reducing the nut's outer diameter while keeping the shaft the same size lowers the weight and can shorten takt time.

Using a smaller and lighter end shaft and peripheral device reduces the load on the motor, which reduces the amount of heat generated and enables equipment to run even longer than before.

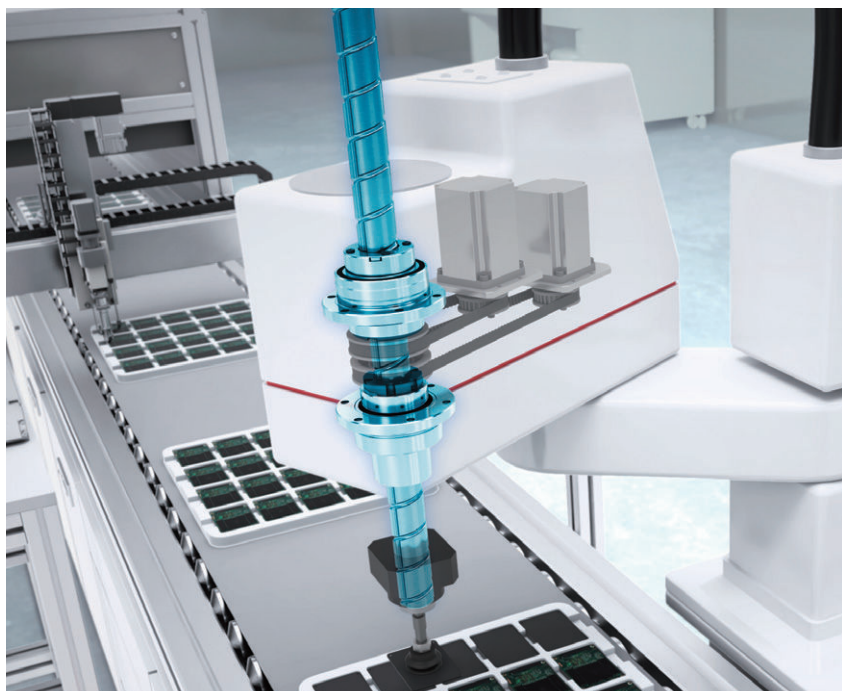

Product Structure

The BNS-V is a combined product with a ball screw nut and ball spline nut inserted directly into the dedicated ball screw and ball spline grooves on the shaft. This ball screw/spline is capable of performing three types of motion (rotational, linear, and spiral) with a single shaft by rotating or stopping each nut.

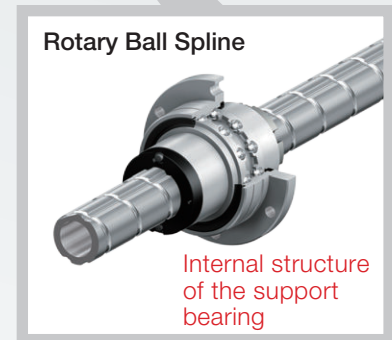
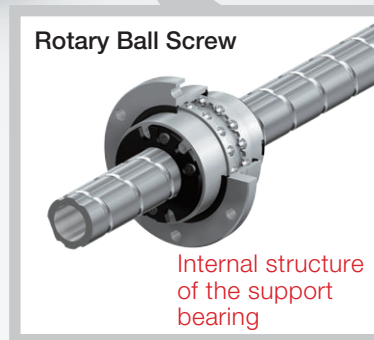
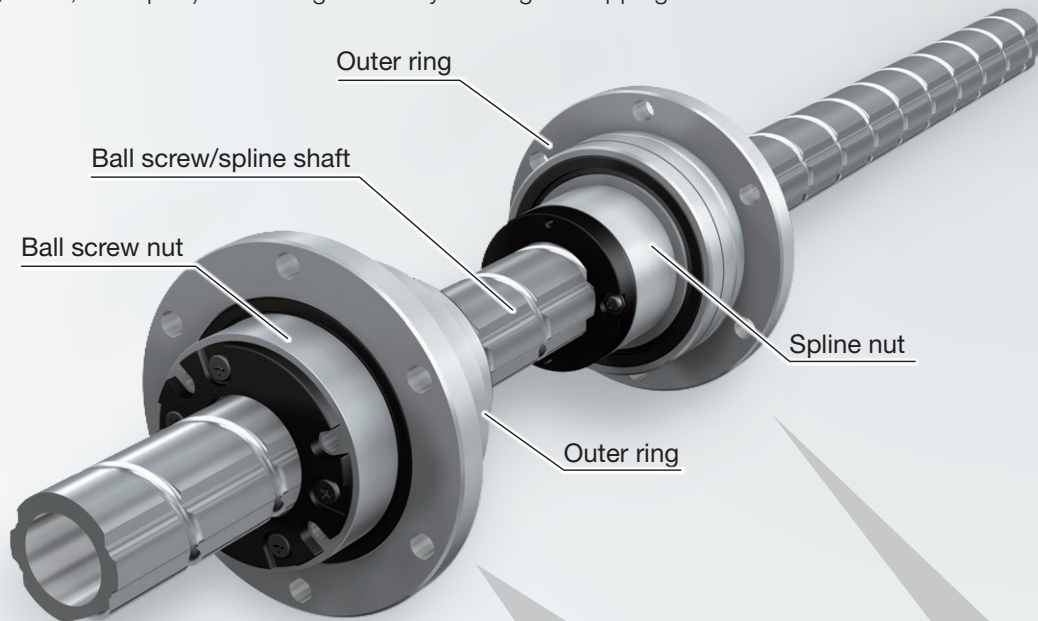

Mechanism of Motion

The BNS-V is capable of performing three types of motion (rotational, linear, and spiral) with a single shaft by rotating or stopping each nut.

1. Linear motion

Rotate ball screw nut

→ The shaft moves up and down (no rotation).

2. Rotary motion

Rotate both ball screw nut and spline nut

→ The shaft rotates in place.

3. Spiral motion

Rotate spline nut

→ The shaft moves up and down while rotating.

Our latest technology improves the performance of the ball screw and ball spline, making this ball screw/spline faster than existing products.

Mechanism of Motion

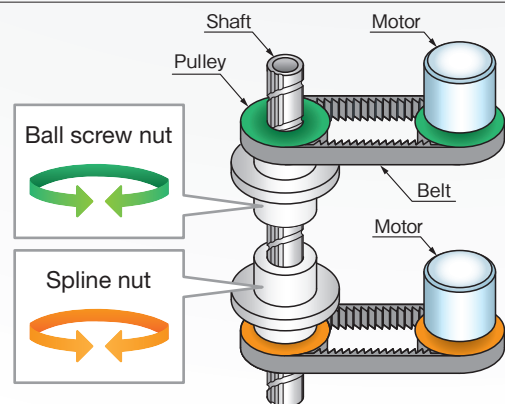

Shaft Motion



1. Linear motion



2. Rotary motion



3. Spiral motion

Lineup

BNS-V

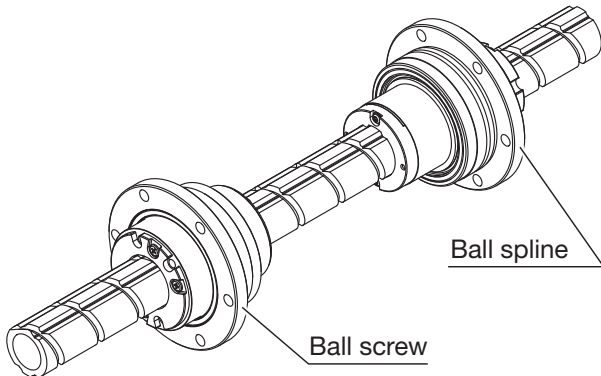

NS-V

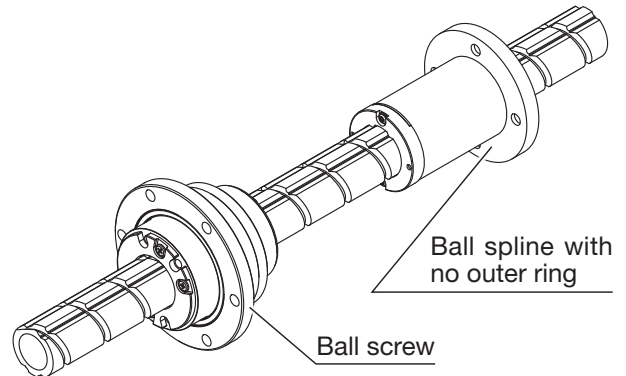

		Lead (mm)		
		16	20	25
Shaft diameter (mm)	16	○	-	-
	20	-	○	-
	25	-	-	○

		Lead (mm)		
		16	20	25
Shaft diameter (mm)	16	○	-	-
	20	-	○	-
	25	-	-	○

Accuracy standards

Ball Screw Lead Angle Accuracy Standard

The accuracy of the ball screw's lead angle is controlled in accordance with JIS standards (JIS B 1192-1997).

Lead angle accuracy of the BNS-V: C5

Lead Angle Accuracy (Permissible Value)

Unit: μm

Accuracy grade		C5	
Effective thread length (mm)		Representative travel distance Error	Fluctuation
Above	Or less		
-	100	18	18
100	200	20	18
200	315	23	18
315	400	25	20
400	500	27	20
500	630	30	23
630	800	35	25

Accuracy Standards for the Mounting Surface

BNS-V

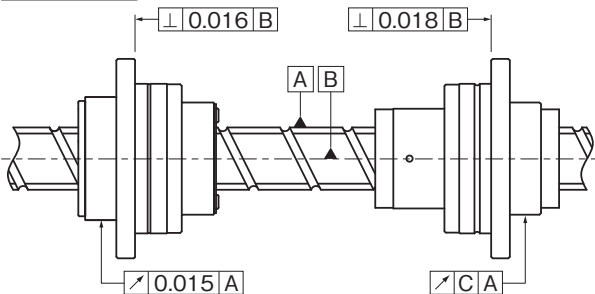

For detailed specifications, see the table below.

NS-V

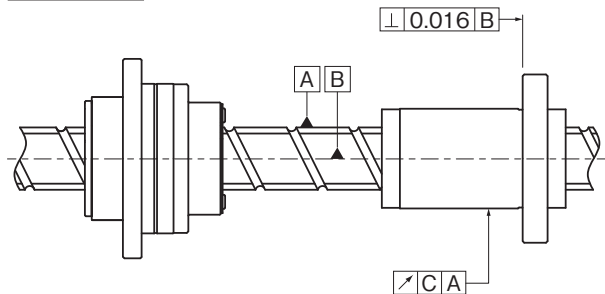

For detailed specifications, see the table below.

Runout of the Spline Nut in Relation to the Supporting Portion of the Spline Shaft

Unit: mm

Overall shaft length		Shaft diameter	
Above	Or less	#16/#20	#25
-	200	0.056	0.032
200	315	0.071	0.039
315	400	0.083	0.044
400	500	0.095	0.050
500	630	0.112	0.057
630	800	0.137	0.068

Model Number Coding

Select an option Fixed symbol

BNS 20 20 V F + 430L C5 H N F

Model No.

Surface treatment
F: AP-C or AP-HC treatment (see p. 6)
No symbol: No surface treatment

Surface treatment
F: AP-C or AP-HC treatment (see p. 6)
No symbol: No surface treatment

Shaft type (see p. 7)
N: N Type hollow spline shaft (standard)
K: K Type hollow spline shaft
No symbol: Solid

Spline accuracy
H: H grade (see left page)

Lead angle accuracy of the screw
C5 (see left page)

Overall screw shaft length (mm)

Standard grease

THK Original Grease AFB-LF

AFB-LF is a general-purpose grease that provides excellent extreme pressure resistance and mechanical stability through the use of a refined mineral oil base oil and a lithium-based consistency enhancer.



Representative Physical Properties

Item	Representative physical properties	Testing method
Consistency enhancer	Lithium-based	
Base oil	Refined Mineral Oil	
Base oil kinematic viscosity: mm ² /s (40°C)	170	JIS K 2220 23
Worked penetration (25°C, 60 W)	275	JIS K 2220 7
Mixing stability (100,000 W)	345	JIS K 2220 15
Dropping point: °C	193	JIS K 2220 8
Evaporation amount: mass% (99°C, 22 h)	0.4	JIS K 2220 10
Oil separation rate: mass% (100°C, 24 h)	0.6	JIS K 2220 11
Copper plate corrosion (B method, 100°C, 24 h)	Accepted	JIS K 2220 9
Low-temperature torque: mN·m (-20°C)	Starting	130
	Rotational	51
4-ball testing (welding load): N	3089	ASTM D2596
Operating temperature range: °C	-15 to 100	
Color	Yellowish brown	

Surface Treatment

Depending on the environment it is used in, the BNS-V/NS-V will require anti-rust treatment. Please contact THK regarding anti-rust treatment.

	Features	Appearance
AP-C	AP-C is a type of industrial-use black chrome coating designed to increase corrosion resistance. It achieves lower cost and higher corrosion resistance than martensite stainless steel.	

	Features	Appearance
AP-HC	Equivalent to industrial-use hard chrome plating, AP-HC achieves almost the same level of corrosion resistance as martensite stainless steel. It is also highly wear-resistant because the film hardness is extremely high, at 750 HV or higher.	

Specification Table

BNS-V

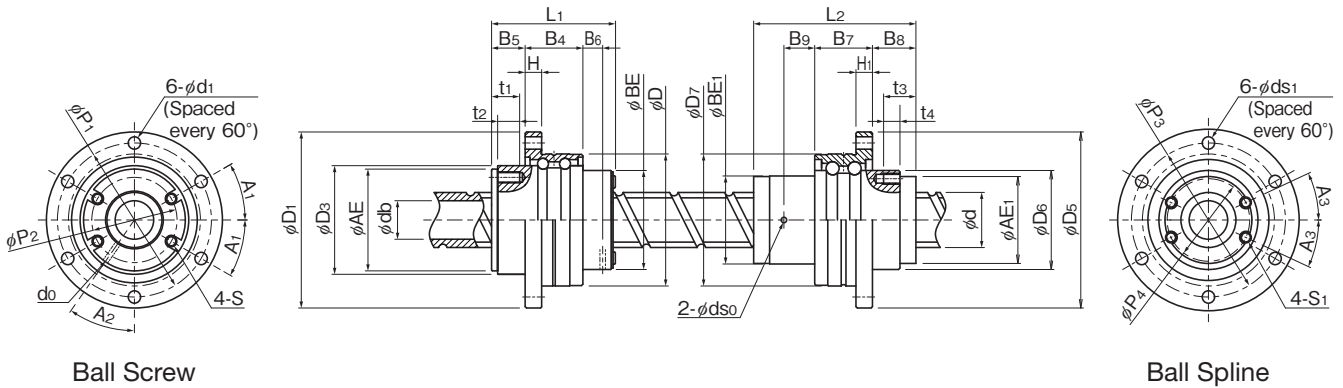

Ball Screw

Ball Spline

Ball Screw

Unit: mm

Model No.	Screw shaft			Ball screw nut dimensions													
	Outer diameter d	Inner diameter db	Lead Ph	Outer diameter D	Flange diameter D ₁	Overall length L ₁	D ₃ h7	AE	BE	H	B ₄	B ₅	B ₆	t ₁	t ₂	d ₁	A ₁
BNS1616V	16	11	16	42	54	38	32.5	31	31	4	18	9.7	5.8	8.2	6	3.4	30°
BNS2020V	20	14	20	48	64	45	39.5	37	36	6	21	12.2	7.2	10.2	8	4.5	30°
BNS2525V	25	18	25	56	72	55	43.5	42	41.6	6	21	13.2	15.3	8.2	6	4.5	30°

Model No.	Ball screw nut dimensions					Support bearing				Nut inertial moment (kg·cm ²)	Screw shaft moment (kg·cm ² /mm)	Nut mass (kg)	Shaft mass (kg/m)
	P ₁	P ₂	S	Greasing hole diameter d ₀	A ₂	Basic load rating		Basic load rating					
						C _a (kN)	C _{0a} (kN)	C _a (kN)	C _{0a} (kN)				
BNS1616V	48	25.5	M3	2	35°	4.6	6.8	6.7	8.6	0.20	3.21×10 ⁻⁴	0.21	0.71
BNS2020V	56	31	M4	2	35°	7.3	11.7	7.3	10.6	0.65	8.04×10 ⁻⁴	0.39	1.11
BNS2525V	64	36	M5	3	35°	8.0	14.4	9.7	13.4	1.02	1.91×10 ⁻³	0.51	1.65

Ball Spline

Unit: mm

Model No.	Ball spline nut dimensions																	
	Outer diameter D ₇	Flange diameter D ₅	Overall length L ₂	D ₅ h7	AE ₁	BE ₁	H ₁	B ₇	B ₈	B ₉	t ₃	t ₄	Greasing hole diameter ds ₀	S ₁	ds ₁	A ₃	P ₃	P ₄
BNS1616V	42	54	46.4	32.5	27.6	28	4	18	13	11.7	11.5	6	2	M3	3.4	20°	48	25
BNS2020V	48	64	59	36	31.6	32	6	21	15.8	15.7	11.8	6	2	M4	4.5	25°	56	30
BNS2525V	56	72	67	43.5	39.6	40	6	21	19.2	18.3	15.2	8	3	M5	4.5	25°	64	36

Model No.	Ball spline nut dimensions					Support bearing		Nut inertial moment (kg·cm ²)	Nut mass (kg)
	Basic load rating		Static permissible moment M _A	Basic torque rating		Basic load rating			
	C (kN)	C ₀ (kN)		C _T (N·m)	C _{0T} (N·m)	C _a (kN)	C ₀ (kN)		
BNS1616V	8.4	13.4	77.4	42.9	68.6	5.2	5.1	0.18	0.19
BNS2020V	10.5	18.6	144	66.4	117.2	6.7	6.4	0.42	0.33
BNS2525V	15.9	26.2	230	125.3	207	7.4	7.8	0.98	0.49

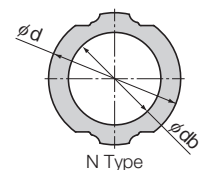

N Type

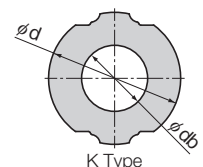

K Type

Shaft Information

Model No.	Outer diameter d (mm)	N Type hollow spline shaft (standard)		K Type hollow spline shaft		Solid		Maximum length of the shaft (mm)	
		Inner diameter db (mm)	Moment of inertia (kg·cm ² /mm)	Mass (kg/m)	Moment of inertia (kg·cm ² /mm)	Mass (kg/m)	Moment of inertia (kg·cm ² /mm)		Mass (kg/m)
BNS/NS1616V	16	11	3.21×10 ⁻⁴	0.71	4.14×10 ⁻⁴	1.15	4.33×10 ⁻⁴	1.45	500L
BNS/NS2020V	20	14	8.04×10 ⁻⁴	1.11	1.02×10 ⁻³	1.70	1.10×10 ⁻³	2.31	630L
BNS/NS2525V	25	18	1.91×10 ⁻³	1.65	2.56×10 ⁻³	2.75	2.71×10 ⁻³	3.64	800L

* If the stroke will be longer than the maximum length of the shaft, contact THK.

NS-V

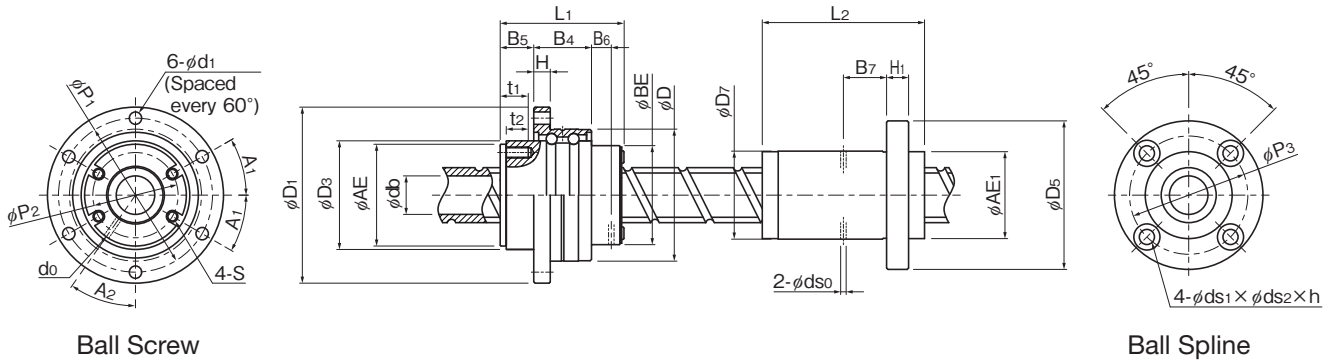

Ball Screw

Ball Spline

Ball Screw

Unit: mm

Model No.	Screw shaft			Ball screw nut dimensions												
	Outer diameter d	Inner diameter db	Lead Ph	Outer diameter D	Flange diameter D ₁	Overall length L ₁	D ₃ h7	AE	BE	H	B ₄	B ₅	B ₆	t ₁	t ₂	d ₁
NS1616V	16	11	16	42	54	38	32.5	31	31	4	18	9.7	5.8	8.2	6	3.4
NS2020V	20	14	20	48	64	45	39.5	37	36	6	21	12.2	7.2	10.2	8	4.5
NS2525V	25	18	25	56	72	55	43.5	42	41.6	6	21	13.2	15.3	8.2	6	4.5

Model No.	Ball screw nut dimensions						Support bearing				Nut inertial moment (kg·cm ²)	Screw shaft moment (kg·cm ² /mm)	Nut mass (kg)	Shaft mass (kg/m)
	A ₁	P ₁	P ₂	S	Greasing hole diameter d ₀	A ₂	Basic load rating		Basic load rating					
							C _a (kN)	C _{0a} (kN)	C _a (kN)	C _{0a} (kN)				
NS1616V	30°	48	25.5	M3	2	35°	4.6	6.8	6.7	8.6	0.20	3.21×10 ⁻⁴	0.21	0.71
NS2020V	30°	56	31	M4	2	35°	7.3	11.7	7.3	10.6	0.65	8.04×10 ⁻⁴	0.39	1.11
NS2525V	30°	64	36	M5	3	35°	8.0	14.4	9.7	13.4	1.02	1.91×10 ⁻³	0.51	1.65

Ball Spline

Unit: mm

Model No.	Ball spline nut dimensions															Nut mass (kg)	
	Outer diameter D ₇	Flange diameter D ₅	Overall length (Without seal) L ₂	AE ₁	H ₁	B ₇	Greasing hole diameter d ₀	P ₃	ds ₁	ds ₂	h	Basic load rating		Static permissible moment M _A	Basic torque rating		
												C (kN)	C ₀ (kN)		C _T (N·m)	C _{0T} (N·m)	
NS1616V	28	48	46.4	27.6	6	11.7	2	38	4.5	8	4.4	8.4	13.4	77.4	42.9	68.6	0.13
NS2020V	32	54	59	31.6	8	15.7	2	43	5.5	9.5	5.4	10.5	18.6	144	66.4	117.2	0.21
NS2525V	40	62	67	39.6	8	18.3	3	51	5.5	9.5	5.4	15.9	26.2	230	125.3	207	0.34

Permissible Rpm

Unit: min⁻¹

Model No.	Ball screw nut		Support bearing			
	DN value	Rpm	Ball screw		Ball spline	
			Grease lubrication	Oil lubrication	Grease lubrication	Oil lubrication
NS1616V	100000	5000	4400	6100	4500	6200
NS2020V	100000	4800	3900	5100	4000	5400
NS2525V	100000	3900	3500	4700	3600	4900

Applications

This product is suited for devices that use both rotary and linear motion, such as the Z-axis of SCARA robots, assembly robots, automated loaders, and ATCs in machining centers.

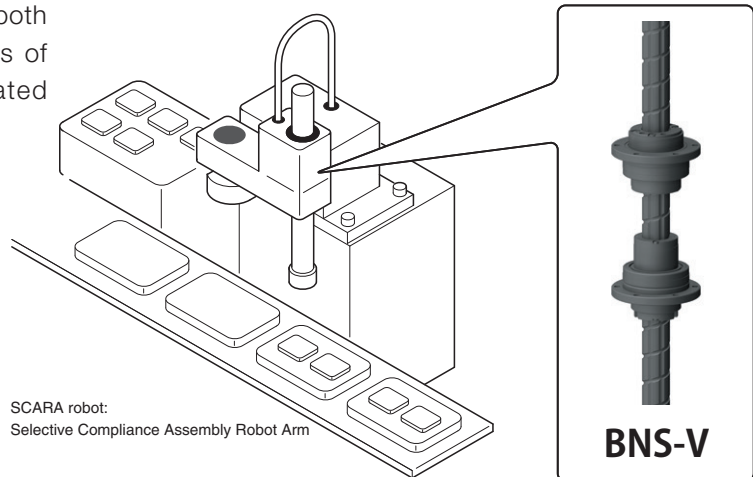

Assembly Examples

BNS-V Examples

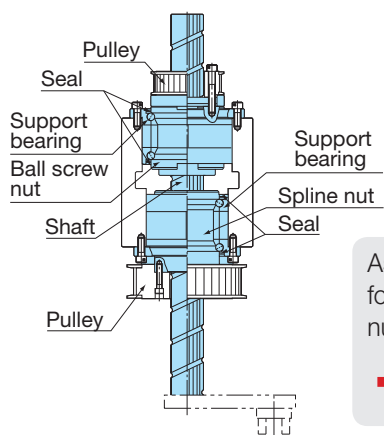

Assembled with the input pulleys for the ball screw nut and spline nut both outside of the housing.
 → The housing length is kept to a minimum.

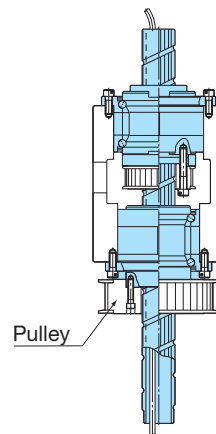

Assembled with the pulley for the ball screw nut inside of the housing.

NS-V Examples

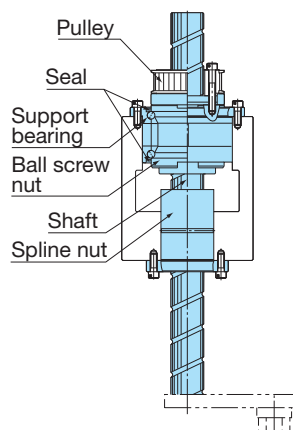

Assembled with the pulley for the ball screw nut outside of the housing.
 → The housing length is kept to a minimum.

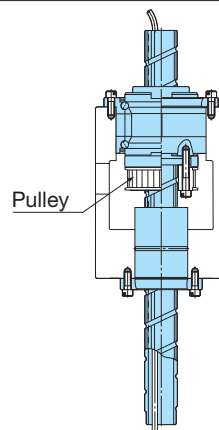

Assembled with the pulley for the ball screw nut inside of the housing.

Handling

1. Please use at least two people to move any product weighing 20 kg or more, or use a cart or another method of conveyance. Otherwise, it may cause injury or damage the unit.
2. Do not disassemble the parts. This will result in loss of functionality.
3. Tilting the screw shaft and nut may cause them to fall under their own weight.
4. Take care not to drop or strike this product. Otherwise, it may cause injury or damage the unit. Even if there is no outward indication of damage, a sudden impact could prevent the unit from functioning properly.
5. When assembling, be sure not to remove the nut from the screw shaft.
6. When handling the product, wear safety gloves and safety boots, etc., as appropriate to ensure proper protection.

Precautions on Use

1. Prevent foreign materials, such as cutting chips or coolant, from entering the product. Failure to do so could damage the product.
2. Prevent foreign materials, such as cutting chips, coolant, corrosive solvents, or water from getting in the product by using a bellows or cover when the product is used in an environment where such a thing is likely.
3. Do not use this product if the external temperature exceeds 80°C. If used above this temperature, there is a risk that the resin and rubber parts may deform or become damaged (except for the heat-resistant type).
4. If foreign materials such as cutting chips adhere to the product, replenish the lubricant after cleaning the product.
5. Slight oscillations can inhibit the formation of an oil film between the raceways and the area of contact for the balls, resulting in fretting. Therefore, be sure to use a type of grease with high fretting resistance. We recommend periodically rotating the nut once to help ensure that a film forms between the raceways and balls.
6. Do not forcibly drive a pin, key, or any other positioning device into the product. This could create indentations in the raceways and impair the product's function.
7. Skewing or misalignment of the nut and the element that supports the shaft can drastically reduce service life. Inspect the components carefully and make sure they are mounted correctly.
8. If any balls fall out of the nut, contact THK. Do not use the product in that condition.
9. If the unit will be mounted vertically, install safety equipment or take other measures to prevent it from falling. There is a chance the nut may fall under its own weight.
10. Do not exceed the permissible rotation speed when using the product. Doing so may cause the product to become damaged or result in an accident. Please keep the rotational speed within THK specifications.
11. Do not allow the nut to overshoot. The product may malfunction if any of the balls fall out, the circulation components become damaged, or any indentations form in the ball raceways. Continuing to use the product under these circumstances may lead to premature wear or damage to the circulation components.
12. Insufficient rigidity or accuracy of the mounting surface could cause an unexpected load to act on the ball screw/spline, which could lead to premature failure of the product. Therefore, give sufficient consideration to the rigidity and accuracy of the housing and base.

Lubrication

1. Thoroughly wipe-off anti-rust oil and feed lubricant before using the product.
2. Do not mix different lubricants. Even grease containing the same type of thickening agent may, if mixed, interact negatively due to disparate additives or other ingredients.
3. When using the product in locations exposed to constant vibrations or in special environments such as in clean rooms, vacuums, and low/high temperatures, use a lubricant suitable for its use/environment.
4. When lubricating products that do not feature a grease nipple or oil hole, directly coat the raceways with lubricant and perform several warm-up strokes to ensure that the grease permeates the interior.
5. Grease viscosity can vary depending on the temperature. Please keep in mind that the torque of the ball screw/spline may be affected by changes in viscosity.
6. Following lubrication, there is the possibility that the rotational torque of the ball screw/spline may increase due to the stirring resistance of the grease. Before commencing operations, make sure to run the unit through several warm-up cycles to ensure that the grease is adequately integrated and dispersed.
7. Excess grease may spatter after lubrication. Wipe off spattered grease as necessary.
8. Grease deteriorates over time, which decreases the lubricity. It is necessary to inspect and replenish the grease in accordance with the usage frequency.
9. The greasing interval varies depending on the usage conditions and environment. We recommend greasing the system approximately every 100 km of travel distance (3 to 6 months). The final greasing interval/amount should be set at the actual machine.
10. There is a risk that lubrication may not work sufficiently if the lubricating oil does not circulate due to the mounting orientation or the oiling port of the nut, so be sure to give these factors adequate consideration during design.
11. It is necessary to use a good quality lubricant when using ball screw/splines. Using the product without lubrication may increase wear on the rolling elements and shorten the service life.

Storage

When storing the ball screw/spline, enclose it in the package designated by THK, and store it indoors and in a horizontal orientation while avoiding any high temperatures, low temperatures, or high levels of humidity. Please note that if the product has been kept in storage for an extended period, the lubricant inside may have deteriorated. Please ensure that you replenish the lubricant before using.

Disposal

The product should be treated as industrial waste and disposed of appropriately.

Recommended Products

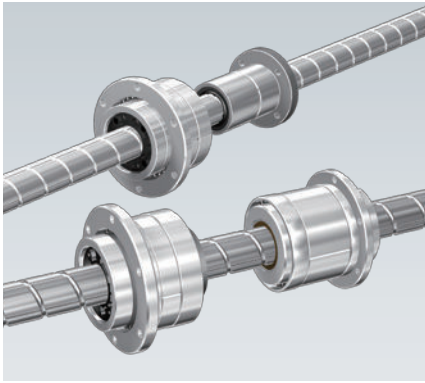

Ball Screw/Spline **BNS/NS**

- High-load support bearing
- Six products are available with a combination of shaft diameters from $\phi 10$ to $\phi 50$ and leads from 16 mm to 50 mm.

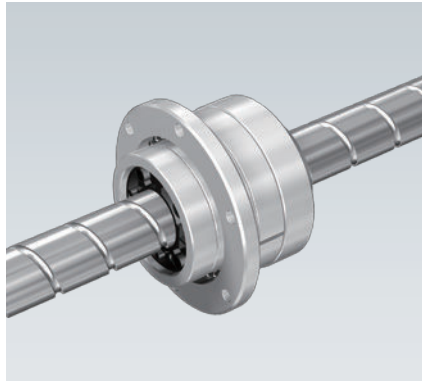

Rotary Ball Screw **BLR**

- Combines a support bearing with a rotary ball screw nut.
- Allows for compact machine designs with fewer components.
- Seven products are available with a combination of shaft diameters from $\phi 16$ to $\phi 50$ and leads from 16 mm to 50 mm.

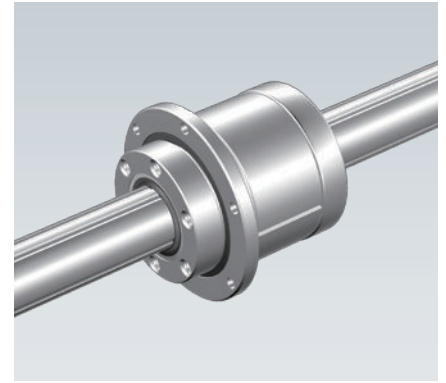

Rotary Ball Spline **LTR**

- Combines a support bearing with a rotary ball spline nut.
- Allows for compact machine designs with fewer components.
- Seven products are available with shaft diameters from $\phi 16$ to $\phi 60$.

Low-Inertia Ball Screw/Spline **BNS-V/NS-V**

●“LM Guide”, “Ball retainer”, and “” are registered trademarks of THK CO., LTD.

- The actual products may differ from the pictures and photographs in this catalog.
- Outward appearances and specifications are subject to change without notice for the purpose of improvement. Please consult with THK before using.
- Although great care has been taken in the production of this catalog, THK will not take any responsibility for damage resulting from typographical errors or omissions.
- For exports of our products and technologies and sales for export, our basic policy is to comply with the Foreign Exchange and Foreign Trade Act and other laws and regulations. Please consult us in advance if you want to export our products by the piece.

All rights reserved

THK CO., LTD.

Headquarters 2-12-10 Shibaura, Minato-ku, Tokyo 108-8506 Japan

International Sales Department Phone: +81-3-5730-3860

www.thk.com