



NEW

Caged Ball LM Guide

SPR/SPS



Implements 8 grooves to achieve super-low waving and ultra-high rigidity

Super precision at the pinnacle of linear motion Materialization of the ideal LM Guide

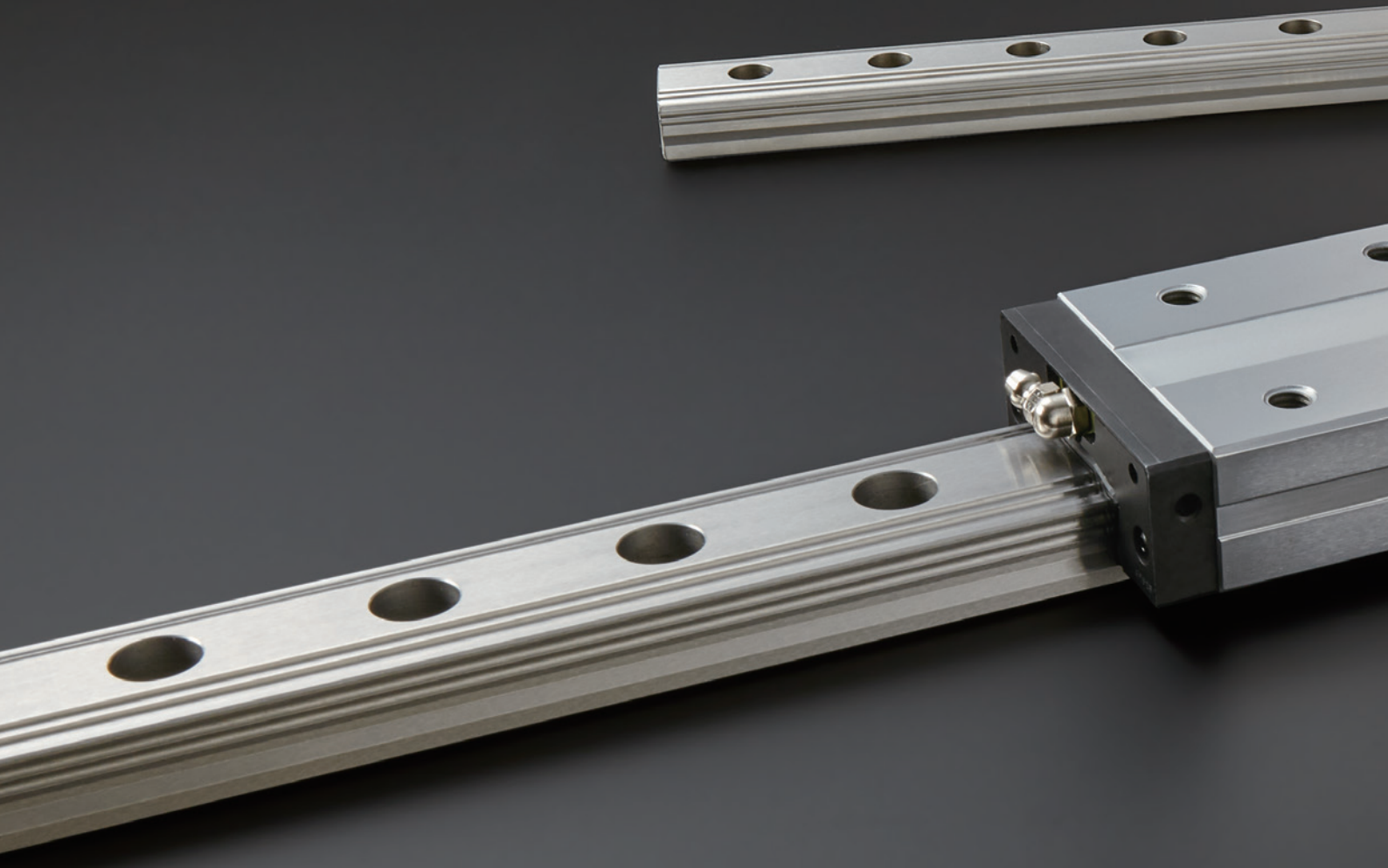

Caged Ball LM Guide

SPR / SPS



Main applications:

Ultra-precision industrial machines, high-precision machining centers, lathes, surface grinders, semiconductor manufacturing equipment, FPD manufacturing equipment, inspection equipment, and high-performance measurement devices

We achieve ultra-low waving and high rigidity through our unique technology.

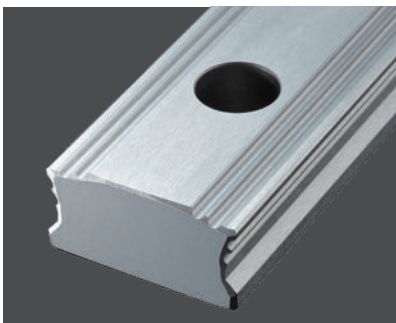

Eight raceway grooves

Doubling the number of grooves halves the load on the balls and enables ultra-low waving on a nanoscopic scale.

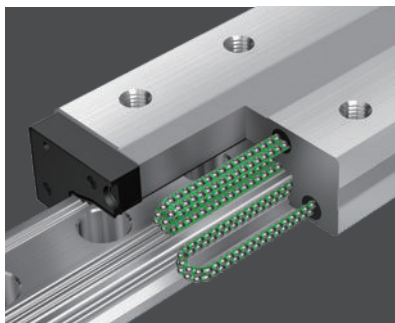

Small-diameter balls

The increased number of load-bearing balls stabilizes support and reduces compression when under a load.



Ultra-long blocks

More balls can be incorporated, reducing each ball's individual load. Demonstrates ultra-low waving and ultra-high rigidity.

Ultra-low waving comparable to that of static pressure guides with ultra-high rigidity exceeding that of roller guides.

Ultra-low waving

Ultra-low waving performance that breaks conventional standards. Proficient in nanometer stroke applications.

Waving Evaluation

Reduced waving range
1/10
of previous models

The product was installed on a single-axis table, and the vertical and horizontal displacement during operation was measured. SPR/SPS models have 1/10 the waving value compared to our conventional, standard LM Guide models (100 nm-300 nm).

Conditions

Test piece	SPS25LR
Rail span	250 mm
Block span	250 mm
Measurement point	Upper 250 mm of the middle of the table
Measurement direction	Vertical, horizontal

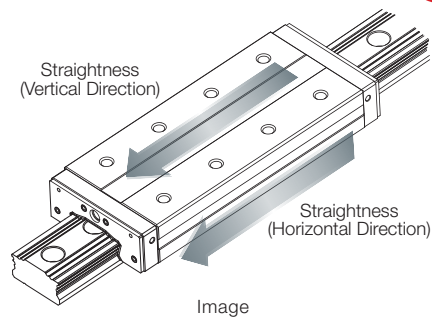

Straightness (Vertical Direction)

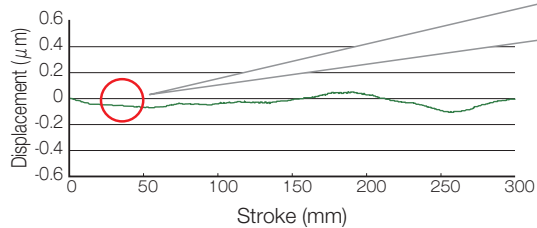

Waving (Vertical Direction)

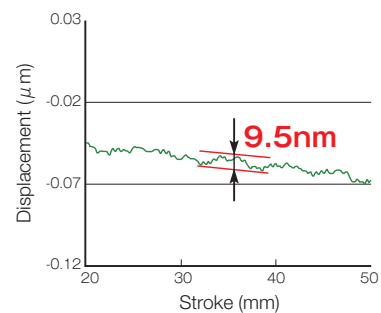

Straightness (Horizontal Direction)

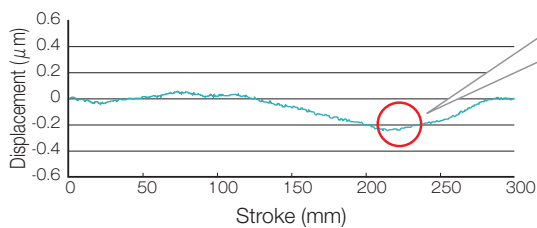

Waving (Horizontal Direction)

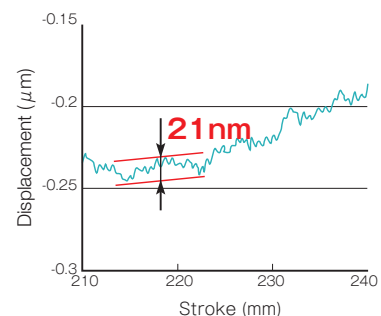

*Internal evaluation results



Ultra-high rigidity

Achieves overwhelming rigidity with small-diameter balls and ultra-long blocks.
Improves the precision of load-bearing strokes and provides stable motion.

Rigidity Comparison and Evaluation

Lowest rigidity displacement among all models

A force was applied to the product from above or below, and the resulting displacement was measured. It achieves even higher rigidity than a roller guide.

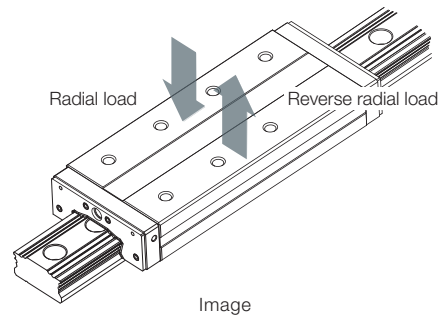

Radial Rigidity

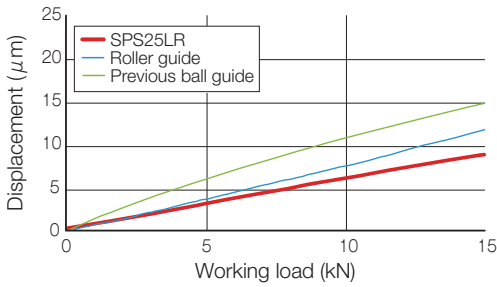

Reverse-Radial Rigidity

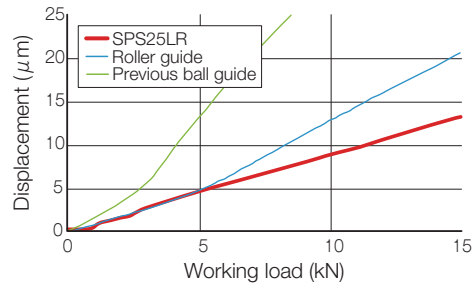

*This test was a comparison at C1 clearance.

Lineup

Both the radial type SPR and the 4-way equal load type SPS are available in the same sizes. Select the correct dimensions for the intended application.

Model No.	Size					
	15	20	25	30	35	45
SPR	○	○	○	○	○	○
SPS	○	○	○	○	○	○

Radial Type
SPR
Cross Section

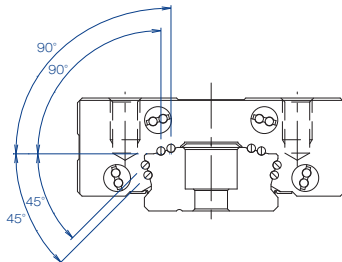

Effective on radial loads when force is applied perpendicular to the shaft. Suitable for the stroke of heavy machines.

4-Way Equal Load Type
SPS
Cross Section

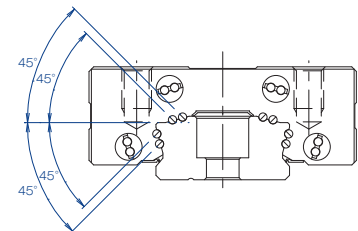

Positions each ball at a contact angle of 45° and bears load from all directions. Can be used in various positions such as horizontally and upside down.

Product Overview

Load Ratings in Each Direction

The Model SPR and SPS are capable of bearing loads in the radial, reverse-radial, and horizontal directions. The basic load rating for the SPR represents the value in the radial direction in the drawing below, and is listed in the SPR specification table.*¹ In addition, the load in the reverse-radial and horizontal directions can be found in the chart below. The basic load rating for the SPS is equal for the four directions (radial direction, reverse-radial direction, and to both sides) and that value is listed in the SPS specification table.*¹

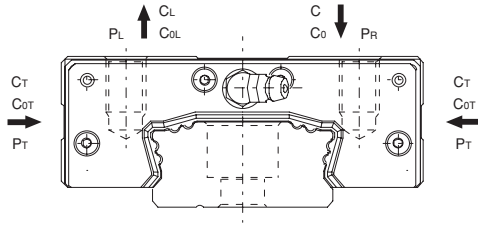

SPR Basic load rating in each direction

Direction	Basic dynamic load rating	Basic static load rating
Radial direction	C	C ₀
Reverse radial direction	C _L =0.71C	C _{OL} =0.71C ₀
Horizontal direction	C _T =0.44C	C _{OT} =0.35C ₀

*¹ SPR/SPS Specification Table
 SPR-LR See p.9
 SPS-LR See p.10

Equivalent Load

Use the formula on the right to determine the equivalent load for an SPR LM block when it bears both reverse-radial and horizontal loads simultaneously.

SPR equivalent-factor

P _E	X	Y
Reverse radial direction equivalent load	1	2

Note) When the reverse-radial and horizontal loads both occur, make this equivalent to the reverse-radial load.

Use the formula on the right to determine the equivalent load for an SPS LM block when it bears loads from each direction simultaneously.

$$P_E = X \cdot P_L + Y \cdot P_T$$

P_E: Equivalent load (N)
 · Reverse radial direction
 P_L: Reverse-radial load (N)
 P_T: Horizontal load (N)
 X, Y: equivalent factor

$$P_E = P_R(P_L) + P_T$$

P_E: Equivalent load (N)
 · Radial direction
 · Reverse radial direction
 P_R: Radial load (N)
 P_L: Reverse-radial load (N)
 P_T: Horizontal load (N)

Static Safety Factor

To calculate a load applied to the LM Guide, you must first obtain the average load required to determine the service life and the maximum load needed to determine the static safety factor. In particular, if the system starts and stops frequently, if a cutting load acts on the system, or if a large moment caused by an overhanging load is applied, it may experience an unexpectedly large load. When selecting a model number, make sure that the desired model is capable of supporting the required maximum load (whether stationary or in motion). The standard values for the static safety factor are shown in the table to the right.

$$f_s = \frac{C_0}{P_{max}}$$

f_s: Static Safety Factor
 C₀: Basic static load rating (N)
 P_{max}: Maximum applied load (N)

Standard Values for the Static Safety Factor (f_s)

Machine	Load conditions	Lower limit of f _s
General industrial machinery	Without vibration or impacts	1.0 to 3.5
	With vibration or impacts	2.0 to 5.0
Machine tools	Without vibration or impacts	1.0 to 4.0
	With vibration or impacts	2.5 to 7.0

* The standard value of the static safety factor may vary depending on usage conditions such as the environment, lubrication status, mounting accuracy, and/or rigidity.

Service Life

The service life of the LM Guide varies from unit to unit even if they are manufactured the same way and used in the same operating conditions. Therefore, the nominal life defined here is typically used as a guideline for obtaining the service life of the LM Guide.

Nominal Life

The nominal life is the total travel distance that 90% of a group of units can achieve without flaking (scale-like pieces on the metal surface peeling off) after individually running under the same conditions.

*¹ Basic dynamic load rating (C)
 Indicates the load for which the nominal life (L) is 50 km when the load is applied with a constant direction and size to a group of identical LM Guide units individually running under the same conditions.

Service Life in Hours

Once the nominal life (L) has been obtained, the service life in hours can be calculated using the following equation if the stroke length and the number of cycles are constant.

$$L = \left(\frac{f_H \cdot f_T \cdot f_C}{f_W} \cdot \frac{C}{P_C} \right)^3 \times 50$$

L: Nominal life (km)
 C: Basic dynamic load rating¹ (N)
 P_C: Calculated load (N)
 f_H: Hardness factor
 f_T: Temperature factor
 f_C: Contact factor
 f_W: Load factor

$$L_h = \frac{L \times 10^6}{2 \times \ell_s \times n_1 \times 60}$$

L_h: Service life (h)
 ℓ_s: Stroke length (mm)
 n₁: Cycles per minute (min⁻¹)

Radial Clearance Specifications

SPR and SPS models have two types of radial clearance (preload). The preload significantly affects the running accuracy, load resistance, and rigidity. Therefore, it is necessary to select a clearance that is appropriate for the application. An appropriate radial clearance will prevent vibrations and impacts from occurring when the device is running, as well as improve the service life and accuracy of the LM Guide.

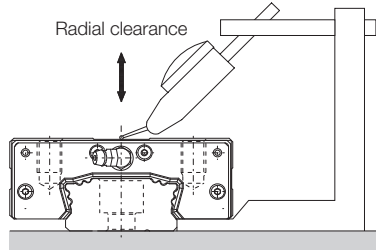

Unit: μm

Model No.	Code	Light preload	Medium preload
		C1	C0
SPR/SPS15		-6 to -4	-9 to -7
SPR/SPS20		-7 to -4	-10 to -7
SPR/SPS25		-8 to -5	-10 to -8
SPR/SPS30		-8 to -5	-12 to -9
SPR/SPS35		-9 to -5	-13 to -10
SPR/SPS45		-11 to -7	-16 to -12

^{*1} Preload
Refers to the internal load applied in advance to the rolling elements (balls) in order to increase the LM Block's rigidity. For SPR and SPS models, all products are shipped with specified radial clearance adjustments.

Accuracy Standards

SPR and SPS models have two grades of accuracy. Accuracy standards are specified in terms of running parallelism,^{*1} dimensional tolerance for height and width, and height and width difference between a pair when two or more LM blocks are used on one rail,^{*2, *3} or when two or more rails are mounted on the same plane.

^{*1} Running Parallelism
Running parallelism refers to the tolerance for parallelism between the LM block and the LM rail datum surface when the LM block travels the whole length of the LM rail with the LM rail bolted to a reference surface.

^{*2} Difference in Height M
The difference in height M indicates the difference between the minimum and maximum values of the height (M) of each of the LM blocks used together on the same plane.

^{*3} Difference in Width W_2
The difference in width W_2 indicates the difference between the minimum and maximum values of the width (W_2) between an LM rail and each of the LM blocks mounted together on the LM rail.

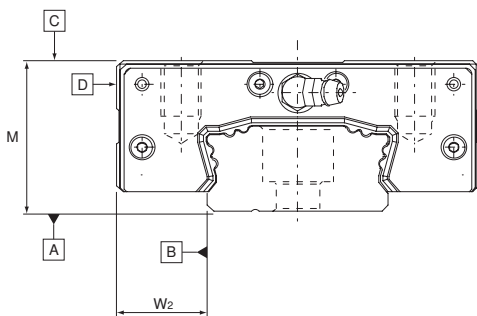

Accuracy Standards

Unit: mm

Model No.	Accuracy grade	Super-precision grade	Ultra-precision grade
	Item	SP	UP
SPR/SPS15 SPR/SPS20	Dimensional tolerance in height M	0 -0.015	0 -0.008
	Difference in height M	0.004	0.003
	Dimensional tolerance in width W_2	0 -0.015	0 -0.008
	Difference in width W_2	0.004	0.003
	Running parallelism of surface C against surface A Running parallelism of surface D against surface B	See table below	
SPR/SPS25 SPR/SPS30 SPR/SPS35	Dimensional tolerance in height M	0 -0.02	0 -0.01
	Difference in height M	0.005	0.003
	Dimensional tolerance in width W_2	0 -0.015	0 -0.01
	Difference in width W_2	0.005	0.003
	Running parallelism of surface C against surface A Running parallelism of surface D against surface B	See table below	
SPR/SPS45	Dimensional tolerance in height M	0 -0.03	0 -0.015
	Difference in height M	0.005	0.003
	Dimensional tolerance in width W_2	0 -0.025	0 -0.015
	Difference in width W_2	0.005	0.003
	Running parallelism of surface C against surface A Running parallelism of surface D against surface B	See table below	

Running Parallelism

Unit: μm

LM rail length (mm)		Running parallelism values	
Above	Or less	Super-precision grade	Ultra-precision grade
		SP	UP
-	50	1.5	1
50	80	1.5	1
80	125	1.5	1
125	200	1.5	1
200	250	1.5	1
250	315	1.5	1
315	400	2	1.5
400	500	2.5	1.5
500	630	3	2
630	800	3.5	2
800	1000	4	2.5
1000	1250	4.5	3
1250	1600	5	4
1600	2000	5.5	4.5
2000	2500	6	5
2500	3090	6.5	5.5

Standard and Maximum Lengths of the LM Rail

The standard and maximum lengths of SPR and SPS model LM rails are shown in the following table. For special rail lengths, it is recommended to use the G,g dimension values from the table. As the G,g dimension increases, this portion becomes less stable, and the accuracy may be negatively affected.

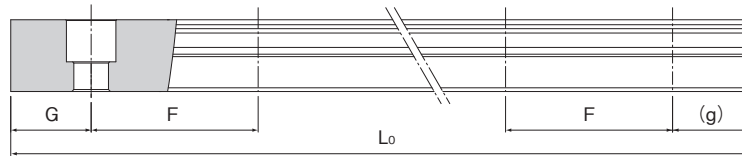

Standard and Maximum Lengths of the SPR and SPS Rail

Unit: mm

Model No.	SPR/SPS15	SPR/SPS20	SPR/SPS25	SPR/SPS30	SPR/SPS35	SPR/SPS45
LM rail standard length L ₀	160	220	280	570	570	780
	220	280	360	675	675	900
	280	340	440	780	780	1020
	340	400	520	885	885	1140
	400	460	600	990	990	1260
	460	520	680	1095	1095	1380
	520	580	760	1200	1200	1500
	580	640	840	1305	1305	1620
	640	700	920	1410	1410	1740
	700	760	1000	1515	1515	1860
	760	820	1080	1620	1620	1980
	820	940	1160	1725	1725	2100
	940	1000	1240	1830	1830	2220
	1000	1060	1320	1935	1935	2340
	1060	1120	1400	2040	2040	2460
	1120	1180	1480	2145	2145	2580
	1180	1240	1560	2250	2250	2700
	1240	1360	1640	2355	2355	2820
	1360	1480	1720	2460	2460	2940
	1480	1600	1800	2565	2565	3060
1600	1720	1880	2670	2670		
		1840	1960	2775	2775	
		1960	2040	2880	2880	
		2080	2200	2985	2985	
		2200	2360	3090	3090	
			2520			
			2680			
Standard pitch F	30	30	40	52.5	52.5	60
G,g	20	20	20	22.5	22.5	30
Maximum length	3000	3000	3000	3090	3090	3060

Note) Joint products are not available.

Shoulder Height of the Mounting Base and the Corner Radius

The mounting base for the LM rail and LM block ordinarily has a reference surface on the side face to allow easy installation and highly accurate positioning.

The corner of the mounting shoulder must be machined to have a recess, or machined to be smaller than the corner radius r , to prevent interference with the chamfer of the LM rail or the LM block.

Unit: mm

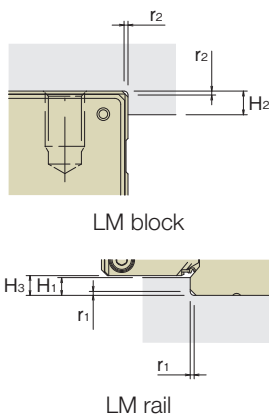

Model No.	Corner radius for the LM rail r_1 (max)	Shoulder height for the LM rail H_1	Corner radius for the LM block r_2 (max)	Shoulder height for the LM block H_2	H_3
SPR/SPS15	0.3	3	0.5	3.5	4
SPR/SPS20	0.3	3	0.5	4	4
SPR/SPS25	0.5	3.5	1	5	4.5
SPR/SPS30	1	4	1	6	5
SPR/SPS35	1	5	1	7	6
SPR/SPS45	1	7	1.5	8	8

Dimensional Tolerance of the Mounting Surface

■ Error Allowance in Parallelism Between Two Rails

Misalignment of the mounting surface can impact the product life of an LM Guide. The table below shows the approximate value (P) of the error allowance in parallelism between two rails under normal use.

Unit: μm

Model No.	C1 clearance	C0 clearance
SPR/SPS15	5	3
SPR/SPS20	6.5	4.5
SPR/SPS25	8.5	7
SPR/SPS30	10.5	9
SPR/SPS35	13	10.5
SPR/SPS45	17.5	14.5

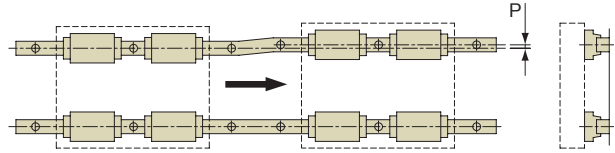

■ Error Allowance in Vertical Level Between Two Rails

The table below shows the approximate value (S) of the error allowance in vertical level between two rails spaced 500 mm apart. The space between rails and the error allowance in vertical level between rails are proportional to each other.

Unit: μm

Model No.	C1 clearance	C0 clearance
SPR15, 20	110	45
SPR25		
SPR30	120	75
SPR35		
SPR45		

Unit: μm

Model No.	C1 clearance	C0 clearance
SPS15, 20	105	60
SPS25		
SPS30		70
SPS35		
SPS45		

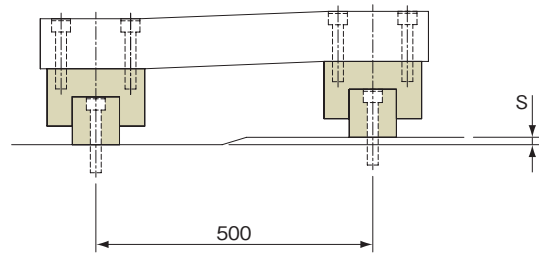

■ Error Allowance in Level in the Axial Direction

The table below shows the approximate value (Y) of the error allowance in the axial direction for LM blocks spaced 500 mm apart. The space between LM blocks and the error allowance in the axial direction are proportional to each other.

Unit: μm

Model No.	C1 clearance	C0 clearance
SPR15, 20	16	7
SPR25		
SPR30		9
SPR35		
SPR45		

Unit: μm

Model No.	C1 clearance	C0 clearance
SPS15, 20	20	12
SPS25	21	14
SPS30		
SPS35		
SPS45		

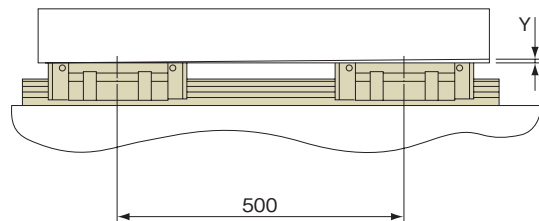

Specification Table

SPR-LR

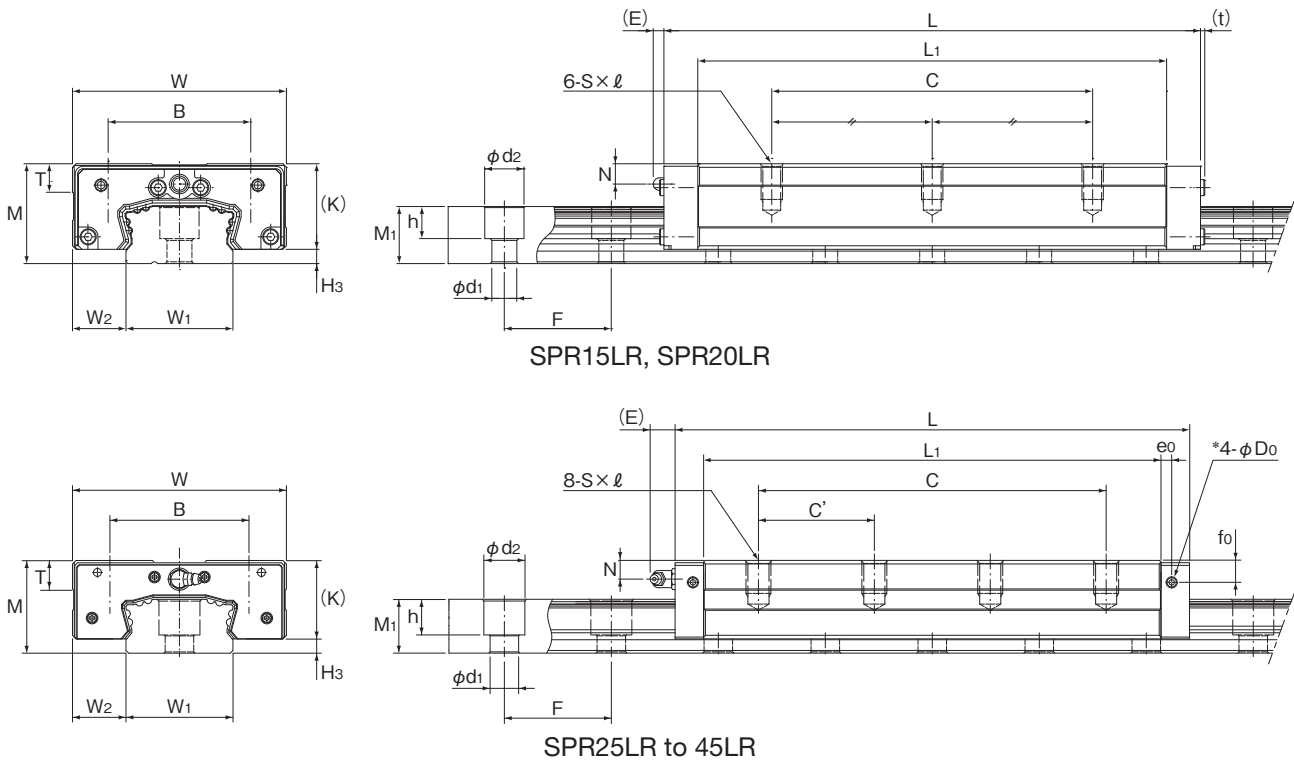

Unit: mm

Model No.	External dimensions			LM block dimensions															H ₃
	Height M	Width W	Length L	t	Mounting hole				L ₁	T	K	N	f ₀	E	e ₀	D ₀	Grease Nipple		
SPR15LR	25	50	121.5	0.8	B	C'	C	S× ϕ	106.5	7	21	5.5	—	3.3	—	—	PB107	4	
SPR20LR	28	60	150.5	1.2	40	—	90	M6×10	131.5	8	24	5.7	—	3	—	—	PB107	4	
SPR25LR	31	72	180.1	—	47	40	120	M8×10.5	158.1	10	26.5	6.3	9.2	12	4.5	3.9	B-M6F	4.5	
SPR30LR	38	90	207.8	—	58	45	135	M10×14	182.6	12	33	8.0	10.9	12	4.5	3.9	B-M6F	5	
SPR35LR	44	100	235.5	—	66	50	150	M12×16	208.3	14	38	9.5	12.4	12	6	5.2	B-M6F	6	
SPR45LR	52	120	288.5	—	78	65	195	M14×18.5	256.5	16	44	10.5	12.3	16	6	5.2	B-PT1/8	8	

Model No.	LM rail dimensions						Basic load rating		Static permissible moment (kN·m) ^{Note 2}					Mass	
	Width W ₁ 0 -0.05	W ₂	Height M ₁	Pitch F	Mounting hole d ₁ ×d ₂ ×h	Length Max ^{Note 1}	C (kN)	C ₀ (kN)	M _A		M _B		M _C	LM block (kg)	LM rail (kg/m)
									1 block	Double blocks	1 block	Double blocks	1 block		
SPR15LR	25	12.5	14	30	6×9.5×8.5	3000	22.5	58.2	0.814	3.65	0.401	1.8	0.454	0.6	2.5
SPR20LR	30	15	16	30	7×11×9	3000	36.8	92.4	1.56	7.05	0.77	3.48	0.84	1.0	3.4
SPR25LR	35	18.5	18.2	40	9×14×12	3000	59.9	156	3.22	14.5	1.69	7.59	1.72	1.5	4.1
SPR30LR	45	22.5	21.4	52.5	11×17.5×14	3090	83.2	212	5.08	22.7	2.66	11.9	3.02	2.7	6.9
SPR35LR	50	25	25	52.5	14×20×17	3090	111	278	7.56	33.6	3.96	17.6	4.37	4.0	9.0
SPR45LR	60	30	30.2	60	16×23×20	3060	178	434	13.8	64.4	7.73	33.7	8.05	7.0	11.6

Model Number Coding

Requires specification

Cannot be changed

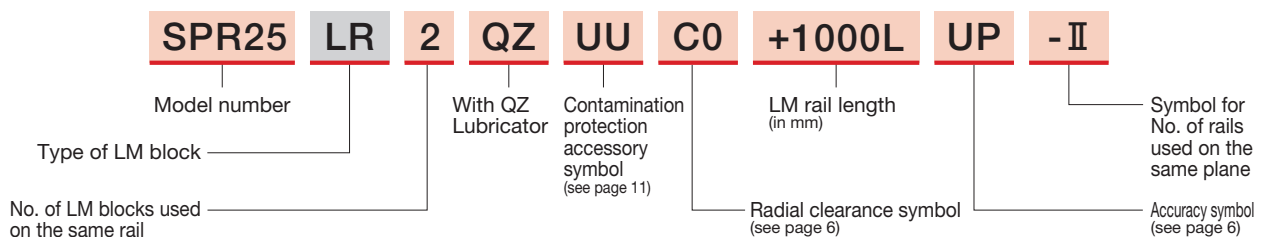

Note) These model numbers refer to a set of LM rails and LM blocks. (When using two guides in parallel, two sets will be needed.)
 Grease nipples are not installed when there is a QZ Lubricator. Contact THK if you want to use a grease nipple for a model with a QZ.

SPS-LR

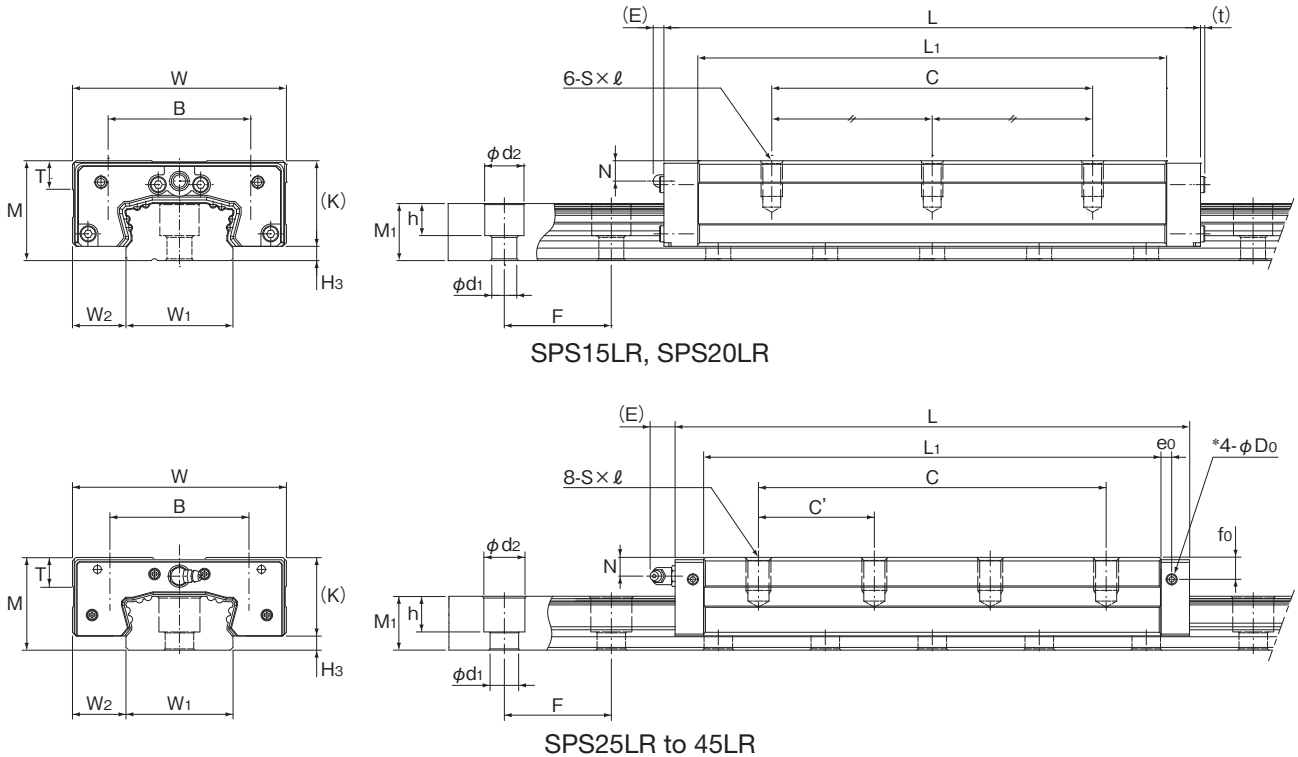

Unit: mm

Model No.	External dimensions			LM block dimensions															H ₃
	Height M	Width W	Length L	t	Mounting hole			S×ℓ	L ₁	T	K	N	f ₀	E	e ₀	D ₀	Grease Nipple		
SPS15LR	25	50	121.5	0.8	B	C'	C	M5×8	106.5	7	21	5.5	—	3.3	—	—	PB107	4	
SPS20LR	28	60	150.5	1.2	40	—	90	M6×10	131.5	8	24	5.7	—	3	—	—	PB107	4	
SPS25LR	31	72	180.1	—	47	40	120	M8×10.5	158.1	10	26.5	6.3	9.2	12	4.5	3.9	B-M6F	4.5	
SPS30LR	38	90	207.8	—	58	45	135	M10×14	182.6	12	33	8.0	10.9	12	4.5	3.9	B-M6F	5	
SPS35LR	44	100	235.5	—	66	50	150	M12×16	208.3	14	38	9.5	12.4	12	6	5.2	B-M6F	6	
SPS45LR	52	120	288.5	—	78	65	195	M14×18.5	256.5	16	44	10.5	12.3	16	6	5.2	B-PT1/8	8	

Model No.	LM rail dimensions						Basic load rating		Static permissible moment (kN·m) ^{Note 2}					Mass	
	Width W ₀ -0.05	W ₂	Height M ₁	Pitch F	Mounting hole d ₁ ×d ₂ ×h	Length Max ^{Note 1}	C (kN)	C ₀ (kN)	M _A		M _B		M _C	LM block (kg)	LM rail (kg/m)
									1 block	Double blocks	1 block	Double blocks			
SPS15LR	25	12.5	14	30	6×9.5×8.5	3000	15.9	41.2	0.728	3.26	0.728	3.26	0.389	0.6	2.5
SPS20LR	30	15	16	30	7×11×9	3000	26	65.3	1.4	9.08	1.4	9.08	0.72	1.0	3.4
SPS25LR	35	18.5	18.2	40	9×14×12	3000	42.4	110	2.91	13.1	2.91	13.1	1.38	1.5	4.1
SPS30LR	45	22.5	21.4	52.5	11×17.5×14	3090	58.8	150	4.59	20.6	4.59	20.6	2.44	2.7	6.9
SPS35LR	50	25	25	52.5	14×20×17	3090	78.2	196	6.83	30.4	6.83	30.4	3.52	4.0	9.0
SPS45LR	60	30	30.2	60	16×23×20	3060	126	307	13.2	58.2	13.2	58.2	6.46	7.0	11.6

Note 1) Max represents the standard maximum length of an LM rail.

Note 2) Static permissible moment 1 block: Static permissible moment value with one LM block.

Double blocks: Static permissible moment value with two blocks in close contact with each other.

Note 3) Do not remove the block from the rail. If the LM block is removed from the LM rail on SPR and SPS models, the balls will fall out.

*1 The diagram shows the nipple pilot holes for when a grease nipple is desired for a product with LaCS or a QZ Lubricator.

In order to prevent foreign material from entering the LM block, these holes are ordinarily not drilled through.

Consult with THK if you desire drilling for grease nipple mounting.

*2 Lubrication

SPR and SPS are filled with lithium soap-based grease No. 2 (AFB-LF grease) as standard.

If you require a different type of grease or a product without grease applied, please contact THK.

If you will use oil lubrication or an automatic lubrication system, please contact THK.

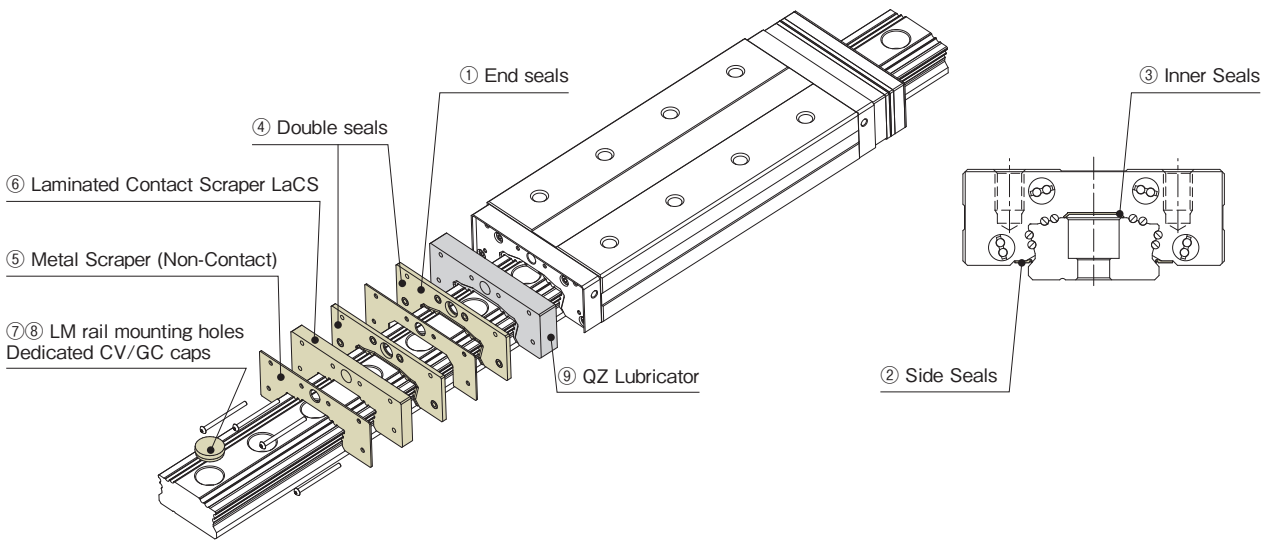

Contamination Protection Accessories

If foreign materials enter the LM Guide, they may lead to abnormal wear and ball jamming, which could shorten the life of the product. Therefore, it is necessary to prevent foreign material from entering the block. If it is likely that foreign materials will get inside, it is important to select an effective contamination protection device suited to the conditions in which it will be used.

① to ⑥Seals

End seals made of a synthetic rubber that are highly resistant to wear and side seals that further improve effective dust-proofing are available.

Use the symbols on p. 13 to specify if you need a contamination protection accessory. See Table 6 for the model numbers of contamination protection accessories and the overall lengths of LM blocks (L dimension) after accessories have been installed.

① End Seals

Standard seals applied to both ends of the LM block. Apply these for use in standard environments (atmosphere and temperature) and normal contaminant levels (dust and machining chips). These seals are intended to remove dust from the top and side surfaces of the LM rail. They also help maintain lubricants inside of the LM block.

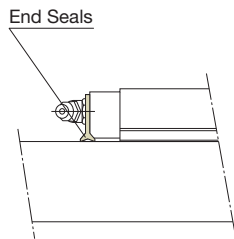

② Side Seals

Standard seals that are applied to the underside of the LM block. Apply these for use in standard environments (atmosphere and temperature) and normal contaminant levels (dust and machining chips). They are intended to prevent contamination by dust from the underside of the LM block. This contamination protection accessory is particularly effective when the mounting position is reversed or the environment is especially dusty.

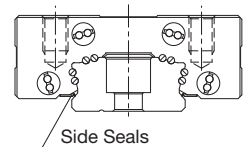

③ Inner Seals

Seals applied close to the ball grooves on the LM block. They are intended to prevent contamination by dust and machining chips from the LM rail mounting holes that end seals alone are unable to remove. C caps and GC caps are also available as additional countermeasures against contamination from the LM rail mounting holes.

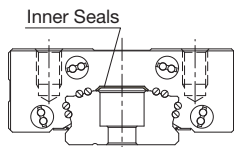

④ Double Seals

A double layer of the standard seals applied to both ends of the LM block. They are intended to remove potential contaminants when dust and machining chips are especially prevalent. *Please note that these will slightly increase the overall length of LM block. Please see the dimension table for the overall lengths of LM blocks.

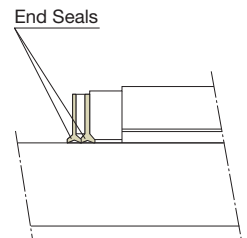

⑤ Metal Scraper (Non-Contact)

Metal seals applied to both ends of the LM block but not making contact with the rail. Always use these in environments where materials such as weld splatter may become stuck on the LM rail. Ordinary end seals will break quickly if used on their own. *Please note that these will slightly increase the overall length of LM block. Please see the dimension table for the overall lengths of LM blocks.

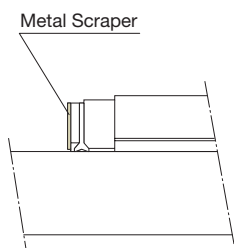

■ Seal Resistance Value

See Table 1 for the maximum seal resistance per LM block when the product is lubricated.

Table 1 Maximum Seal Resistance Values

Unit: N

Model No.	UU	SS
SPR/SPS15	2	6
SPR/SPS20	2	6
SPR/SPS25	3	7
SPR/SPS30	5	11
SPR/SPS35	8	16
SPR/SPS45	10	20

⑥ Laminated Contact Scraper LaCS

Laminated seals applied to both ends of the LM block. Harsh environments in which coolant and fine particles contact the LM Guide could lead to early damage of the product. With the three-layered laminated contact structure of the LaCS, each layer removes minute foreign material adhering to the LM rail and prevents it from entering the LM block. However, please note that these will slightly increase the overall length of LM block.

■ Features

- Because the three layers of scrapers fully contact the LM rail, the LaCS is highly capable of removing minute foreign material.
- Low friction resistance is achieved through the use of oil-impregnated, self-lubricating synthetic foam rubber.

■ General Specifications of LaCS

- Temperature range for using LaCS: -20°C to 80°C
- LaCS resistance value (reference): See Table 2 for maximum LaCS resistance values.

Note) The LaCS is not available for individual sale.

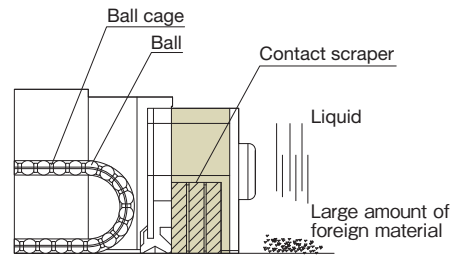

Table 2 LaCS Resistance Values

Unit: N

Model No.	Maximum resistance value
SPR/SPS25	13.0
SPR/SPS30	20.2
SPR/SPS35	22.9
SPR/SPS45	27.4

Note 1) This represents only the resistance of the LaCS and excludes resistance from the LM block and seals.

Note 2) Please contact THK about the maximum speed when using LaCS.

⑦⑧ Dedicated Cap for LM Rail Mounting Holes

Using dedicated caps to cover the LM rail mounting holes helps prevent foreign material from entering the mounting holes and LM block.

■ Cap CV

The caps are made of a special synthetic resin. The CV cap is the successor to the C cap, and its new structure makes it easier to insert.

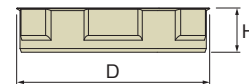

Table 3-1

Model No.	CV cap model	Bolts used	Main dimensions (mm)	
			D	H
SPR/SPS15	CV5	M5	9.8	2.4
SPR/SPS20	CV6	M6	11.4	2.6
SPR/SPS25	CV8	M8	14.4	3.3
SPR/SPS30	CV10	M10	17.9	3.3
SPR/SPS35	CV12	M12	20.5	3.4
SPR/SPS45	CV14	M14	23.4	5.5

■ Cap GC

GC caps are made of metal. (They are RoHS compliant.) GC caps adhere closer to the counterbore than CV caps and C caps, so there is no clearance once they are inserted.

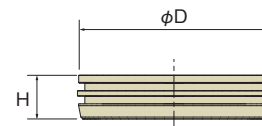
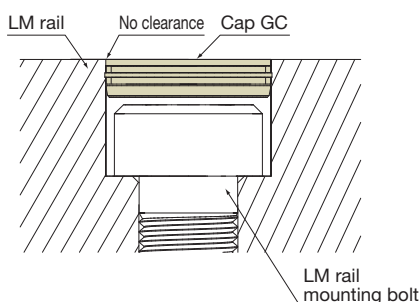

Table 3-2

Model No.	GC cap model	Bolts used	Main dimensions (mm)	
			D	H
SPR/SPS15	GC5	M5	9.86	2.5
SPR/SPS20	GC6	M6	11.36	2.5
SPR/SPS25	GC8	M8	14.36	3.5
SPR/SPS30	GC10	M10	17.86	3.5
SPR/SPS35	GC12	M12	20.36	4.6
SPR/SPS45	GC14	M14	23.36	5.0

Note 1) GC caps are only sold with LM Guides. They are not sold separately. The LM Guide model number code will have "GC" at the end when it is delivered.

SPR25 LR 2 QZ KKHH C0 + 1200L UP - II **GC**

GC caps attached

Note 2) GC caps cannot be used with LM rails that are made of stainless steel or rails that have undergone surface treatment.

Note 3) LM rail mounting holes for GC caps are special. (The mouth is not chamfered.)

Note 4) Be careful not to injure your hand when inserting GC caps.

Note 5) Be sure to make the GC caps level with the upper surface of the LM rail and clean (wipe) that surface after insertion.

Note 6) If this product will be used in special environments, such as in a vacuum or at very low or high temperatures, contact THK.

Specialized Bellows

Please contact THK for more information about specialized bellows.

Lubricating Components

Standard Grease

AFB-LF Grease is a general-purpose grease that provides excellent extreme pressure resistance and mechanical stability through the use of a refined mineral oil base oil and a lithium-based consistency enhancer.

*Non-standard greases are also available. Contact THK for details.

Table 4 AFB-LF Representative Physical Properties

Item	Representative value	Test method
Consistency enhancer	Lithium-based	
Base oil	Refined mineral oil	
Base oil kinematic viscosity: mm ² /s (40°C)	170	JIS K 2220 23
Worked penetration (25°C, 60 W)	275	JIS K 2220 7
Mixing stability (100,000 W)	345	JIS K 2220 15
Dropping point: °C	193	JIS K 2220 8
Evaporation amount: mass% (99°C, 22 h)	0.4	JIS K 2220 10
Oil separation rate: mass% (100°C, 24 h)	0.6	JIS K 2220 11
Copper plate corrosion (R method, 100°C, 24 h)	Pass	JIS K 2220 9
Low-temperature torque: mN·m (-20°C)	Starting	JIS K 2220 18
	Rotational	
4-ball testing (welding load): N	3089	ASTM D2596
Service temperature range: °C	-15 to 100	
Color	Yellowish brown	

⑨ QZ Lubricator

The QZ Lubricator is a lubricator attached to both ends of the LM block. The QZ Lubricator feeds the right amount of lubricant directly to the LM rail raceway. This allows an oil film to be constantly formed between the balls and the raceway, and it significantly extends the lubrication maintenance interval. In addition, this lubrication system is environmentally friendly because it does not make the LM Guide's surroundings dirty. The QZ Lubricator is made primarily of three components, and lubricant is supplied to the LM Guide's raceways from within the QZ Lubricator using the basic principle of capillary action, as used in felt-tip pens. However, please note that these will slightly increase the overall length of LM block.

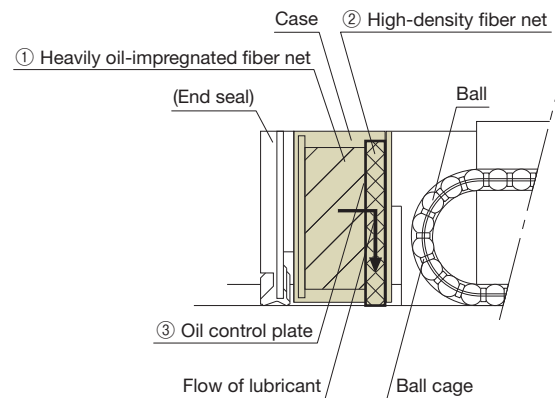

■ Features

- Since it compensates for oil loss, the lubrication maintenance interval can be significantly extended.
- It is an eco-friendly lubrication system that does not contaminate the surrounding area, as it feeds the right amount of lubricant to the ball raceway.

Table 5 Component Codes for SPR and SPS Models with QZ Lubricators

Symbol	Contamination protection accessories with QZ Lubricators
QZUU	End seals + QZ
QZSS	End seals + side seals + inner seals + QZ
QZDD	Double seals + side seals + inner seals + QZ
QZZZ	End seals + side seals + inner seals + metal scrapers + QZ
QZKK	Double seals + side seals + inner seals + metal scrapers + QZ
QZSSHH	End seals + side seals + inner seals + LaCS + QZ
QZDDHH	Double seals + side seals + inner seals + LaCS + QZ
QZZZHH	End seals + side seals + inner seals + metal scrapers + LaCS + QZ
QZKKHH	Double seals + side seals + inner seals + metal scrapers + LaCS + QZ

Please contact THK about the increased dimensions when applying a grease nipple.

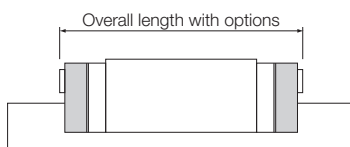

Table 6 Overall Length of Model SPR and SPS LM Blocks After Applying QZ Lubricators

Model No.	QZUU (SS)	QZDD	QZZZ	QZKK	QZSSHH	QZDDHH	QZZZHH	QZKKHH
SPR/SPS15	144.1	147.5	148.9	152.3	—	—	—	—
SPR/SPS20	173.9	177.9	179.1	183.1	—	—	—	—
SPR/SPS25	202.1	209.5	207.8	215.2	222.4	229.8	224.8	232.2
SPR/SPS30	229.8	238.2	236.3	244.7	253.1	261.5	256.3	264.7
SPR/SPS35	267.5	275.9	274	282.4	290.8	299.2	294	302.4
SPR/SPS45	320.5	329.9	327	336.4	343.8	353.2	347	356.4

Handling

- (1) Please use at least two people to move any product weighing 20 kg or more, or use a cart or another method of conveyance. Otherwise, it may cause injury or damage the unit.
- (2) Do not disassemble the parts. This will result in loss of functionality.
- (3) Tilting an LM block or LM rail may cause them to fall by their own weight.
- (4) Take care not to drop or strike the LM Guide. Otherwise, it may cause injury or damage the unit. Even if there is no outward indication of damage, a sudden impact could prevent the unit from functioning properly.
- (5) Do not remove the LM block from the LM rail during setup.
- (6) Do not insert hands or fingers into the mounting holes on the LM rail, as they could get caught between the rail and the LM block, resulting in injury.
- (7) When handling the product, wear safety gloves and safety boots, etc., as appropriate to ensure proper protection.

Precautions on Use

- (1) Prevent foreign materials, such as cutting chips or coolant, from entering the product. Failure to do so could damage the product.
- (2) Prevent foreign materials, such as cutting chips, coolant, corrosive solvents, or water from getting in the product by using a bellows or cover when the product is used in an environment where such a thing is likely.
- (3) Do not use this product if the external temperature exceeds 80°C. If used above this temperature, there is a risk that the resin and rubber parts may deform or become damaged (except for the heat-resistant type).
- (4) If foreign materials such as cutting chips adhere to the product, replenish the lubricant after cleaning the product.
- (5) Micro-strokes can inhibit the formation of an oil film between the raceways and the area of contact for the balls, resulting in fretting. Therefore, be sure to use a type of grease with high fretting resistance. We recommend periodically causing the unit to make a stroke equal to the length of the LM block to help ensure that a film forms between the raceways and balls.
- (6) Do not forcibly drive a pin, key, or any other positioning device into the product. This could create indentations in the raceways and impair the product's function.
- (7) If, for operational reasons, it becomes absolutely necessary to remove the LM block from the LM rail and reattach it, a special mounting jig must be used for this purpose. (The mounting jig is not included with standard versions of the product. To obtain one, please contact THK.)
- (8) Position the mounting jig so that one end fully touches the end of the LM rail. When the rail and the jig are exactly aligned, the LM block can be loaded onto the rail.
- (9) Take care to keep the LM block straight. Loading the block at an angle can introduce foreign matter, damage internal components, or cause balls to fall out.
- (10) The LM block must contain all its internal rolling elements (balls) when mounted on the LM rail. Using a block with any balls removed may result in premature damage.
- (11) If any balls fall out of the LM block, contact THK. Do not use the product in that condition.
- (12) If the LM Guide breaks due to an accident or other cause, the block may come off of the rail and fall. For the safe use of this product, take precautions such as adding a mechanism to prevent the block from falling.
- (13) Insufficient rigidity or accuracy of the mounting surface could cause the bearing load to concentrate on one point, and the bearing performance will drop significantly. Therefore, give sufficient consideration to the rigidity and accuracy of the housing and base as well as the strength of the bolts.
- (14) When removing the LM block from the LM rail and then replacing the block, an LM block mounting/removing jig that facilitates such installation is available. Contact THK for details.

Lubrication

- (1) Thoroughly wipe off anti-rust oil and feed lubricant before using the product.
- (2) Do not mix different lubricants. Even grease containing the same type of thickening agent may, if mixed, interact negatively due to disparate additives or other ingredients.
- (3) When using the product in locations exposed to constant vibrations or in special environments such as in clean rooms, vacuums, and low/high temperatures, use a lubricant suitable for its use/environment.
- (4) When lubricating products that do not feature a grease nipple or oil hole, directly coat the raceways with lubricant and perform several warm-up strokes to ensure that the grease permeates the interior.
- (5) Grease viscosity can vary depending on the temperature. Please keep in mind that the sliding resistance of the LM Guide may be affected by changes in viscosity.
- (6) After lubrication, the slide resistance of the LM Guide may increase due to the stirring resistance of grease. Be sure to let the grease spread fully before operating the machine.
- (7) Excess grease may spatter after lubrication. Wipe off spattered grease as necessary.
- (8) Grease deteriorates over time, which decreases the lubricity. It is necessary to inspect and replenish the grease in accordance with the usage frequency.
- (9) The greasing interval varies depending on the usage conditions and environment. We recommend greasing the system approximately every 100 km of travel distance (3 to 6 months). The final greasing interval/amount should be set at the actual machine.
- (10) If the product is mounted in a non-horizontal orientation, the lubricant may not reach the raceway completely.
- (11) When adopting oil lubrication, the lubricant may not be distributed throughout the LM block depending on the mounting orientation of the block. Contact THK in advance for details.

Storage

When storing the LM Guide, enclose it in the package designated by THK, and store it indoors and in a horizontal orientation while avoiding any high temperatures, low temperatures, or high levels of humidity. Please note that if the product has been kept in storage for an extended period, the lubricant inside may have deteriorated. Please ensure that you replenish the lubricant before using.

Disposal

The product should be treated as industrial waste and disposed of appropriately.

Caged Ball LM Guide SPR/SPS

●“LM Guide” and “” are registered trademarks of THK CO., LTD.

- The actual products may differ from the pictures and photographs in this catalog.
- Outward appearances and specifications are subject to change without notice for the purpose of improvement. Please consult with THK before using.
- Although great care has been taken in the production of this catalog, THK will not take any responsibility for damage resulting from typographical errors or omissions.
- For exports of our products and technologies and sales for export, our basic policy is to comply with the Foreign Exchange and Foreign Trade Act and other laws and regulations. Please consult us in advance if you want to export our products by the piece.

All rights reserved

THK CO., LTD.

Headquarters 2-12-10 Shibaura, Minato-ku, Tokyo 108-8506 Japan

International Sales Department Phone: +81-3-5730-3860

www.thk.com
